



12th Generation Intel® Core™ Processors

Datasheet, Volume 1 of 2

Rev. 011

You may not use or facilitate the use of this document in connection with any infringement or other legal analysis concerning Intel products described herein. You agree to grant Intel a non-exclusive, royalty-free license to any patent claim thereafter drafted which includes subject matter disclosed herein.

No license (express or implied, by estoppel or otherwise) to any intellectual property rights is granted by this document.

All information provided here is subject to change without notice. Contact your Intel representative to obtain the latest Intel product specifications and roadmaps.

The products described may contain design defects or errors known as errata which may cause the product to deviate from published specifications. Current characterized errata are available on request.

Intel technologies' features and benefits depend on system configuration and may require enabled hardware, software or service activation. Performance varies depending on system configuration. No computer system can be absolutely secure. Check with your system manufacturer or retailer or learn more at [intel.com](https://www.intel.com).

Intel technologies' features and benefits depend on system configuration and may require enabled hardware, software or service activation. Performance varies depending on system configuration. No computer system can be absolutely secure. Check with your system manufacturer or retailer or learn more at [\[intel.com\]](https://www.intel.com).

*Other names and brands may be claimed as the property of others.

Contents

1. Revision History	10
2. Introduction	12
2.1 Processor Volatility Statement	21
2.2 Package Support	21
2.3 Supported Technologies	22
2.3.1 API Support (Windows*)	23
2.4 Power Management Support	24
2.4.1 Processor Core Power Management	24
2.4.2 System Power Management	24
2.4.3 Memory Controller Power Management	24
2.4.4 Processor Graphics Power Management	25
2.5 Thermal Management Support	25
2.6 Ball-out Information	26
2.7 Processor Testability	26
2.8 Operating Systems Support	26
2.9 Terminology and Special Marks	27
2.10 Related Documents	34
3. Technologies	35
3.1 Platform Environmental Control Interface	35
3.1.1 PECl Bus Architecture	35
3.2 Intel® Virtualization Technology	37
3.2.1 Intel® VT for Intel® 64 and Intel® Architecture	37
3.2.2 Intel® Virtualization Technology for Directed I/O	40
3.2.3 Intel® APIC Virtualization Technology (Intel® APICv)	42
3.2.4 Hypervisor-Managed Linear Address Translation	43
3.3 Security Technologies	44
3.3.1 Intel® Trusted Execution Technology	44
3.3.2 Intel® Advanced Encryption Standard New Instructions	45
3.3.3 Perform Carry-Less Multiplication Quad Word Instruction	45
3.3.4 Intel® Secure Key	46
3.3.5 Execute Disable Bit	46
3.3.6 Boot Guard Technology	46
3.3.7 Intel® Supervisor Mode Execution Protection	46
3.3.8 Intel® Supervisor Mode Access Protection	47
3.3.9 Intel® Secure Hash Algorithm Extensions	47
3.3.10 User Mode Instruction Prevention	47
3.3.11 Read Processor ID	48

3.3.12	Intel® Total Memory Encryption - Multi-Key	48
3.3.13	Intel® Control-flow Enforcement Technology	49
3.3.13.1	Shadow Stack	49
3.3.13.2	Indirect Branch Tracking	49
3.3.14	KeyLocker Technology	49
3.3.15	Devil's Gate Rock	50
3.4	Power and Performance Technologies	50
3.4.1	Intel® Smart Cache Technology	50
3.4.2	IA Cores Level 1 and Level 2 Caches	50
3.4.3	Ring Interconnect	51
3.4.4	Intel® Performance Hybrid Architecture	51
3.4.5	Intel® Turbo Boost Max Technology 3.0	52
3.4.6	Intel® Hyper-Threading Technology	52
3.4.7	Intel® Turbo Boost Technology 2.0	52
3.4.7.1	Intel® Turbo Boost Technology 2.0 Power Monitoring	53
3.4.7.2	Intel® Turbo Boost Technology 2.0 Power Control	53
3.4.7.3	Intel® Turbo Boost Technology 2.0 Frequency	53
3.4.8	Enhanced Intel SpeedStep® Technology	53
3.4.9	Intel® Thermal Velocity Boost (Intel® TVB)	54
3.4.10	Intel® Speed Shift Technology	54
3.4.11	Intel® Advanced Vector Extensions 2 (Intel® AVX2)	54
3.4.11.1	Intel® AVX2 Vector Neural Network Instructions (AVX2 VNNI)	55
3.4.12	Intel® 64 Architecture x2APIC	55
3.4.13	Intel® Dynamic Tuning Technology	56
3.4.14	Intel® GMM and Neural Network Accelerator	56
3.4.15	Cache Line Write Back	57
3.4.16	Remote Action Request	57
3.4.17	User Mode Wait Instructions	58
3.5	Intel® Image Processing Unit	58
3.5.1	Platform Imaging Infrastructure	58
3.5.2	Intel® Image Processing Unit	59
3.6	Debug Technologies	59
3.6.1	Intel® Processor Trace	60
3.6.2	Platform CrashLog	60
3.6.3	Telemetry Aggregator	60
3.7	Clock Topology	61
3.7.1	Integrated Reference Clock PLL	62
3.8	Intel Volume Management Device Technology	62
3.9	Deprecated Technologies	64
4.	Power Management	64
4.1	Advanced Configuration and Power Interface (ACPI) States Supported	66
4.2	Processor IA Core Power Management	69

4.2.1 OS/HW Controlled P-states	69
4.2.1.1 Enhanced Intel SpeedStep® Technology	69
4.2.1.2 Intel® Speed Shift Technology	54
4.2.2 Low-Power Idle States	69
4.2.3 Requesting the Low-Power Idle States	70
4.2.4 Processor IA Core C-State Rules	70
4.2.5 Package C-States	72
4.2.6 Package C-States and Display Resolutions	76
4.3 Processor AUX Power Management	76
4.4 Processor Graphics Power Management	25
4.4.1 Memory Power Savings Technologies	77
4.4.2 Display Power Savings Technologies	77
4.4.3 Processor Graphics Core Power Savings Technologies	78
4.5 System Agent Enhanced Intel SpeedStep® Technology	79
4.6 Rest Of Platform (ROP) PMIC	79
4.7 PCI Express* Power Management	79
4.8 TCSS Power State	80
5. Thermal Management	81
5.1 Processor Thermal Management	81
5.1.1 Thermal Considerations	82
5.1.1.1 Package Power Control	83
5.1.1.2 Platform Power Control	84
5.1.1.3 Turbo Time Parameter (Tau)	85
5.1.2 Assured Power (cTDP)	85
5.1.2.1 Assured Power (cTDP)	85
5.1.3 Thermal Management Features	86
5.1.3.1 Adaptive Thermal Monitor	86
5.1.3.2 Digital Thermal Sensor	89
5.1.3.3 PROCHOT# Signal	90
5.1.3.4 PROCHOT Output Only	90
5.1.3.5 Bi-Directional PROCHOT#	90
5.1.3.6 PROCHOT Demotion Algorithm	91
5.1.3.7 Voltage Regulator Protection using PROCHOT#	91
5.1.3.8 Thermal Solution Design and PROCHOT# Behavior	91
5.1.3.9 Low-Power States and PROCHOT# Behavior	92
5.1.3.10 THRMTRIP# Signal	92
5.1.3.11 Critical Temperature Detection	92
5.1.3.12 On-Demand Mode	92
5.1.3.13 MSR Based On-Demand Mode	93
5.1.3.14 I/O Emulation-Based On-Demand Mode	93
5.1.4 Intel® Memory Thermal Management	93
5.2 Processor Line Thermal and Power Specifications	93

5.2.1	Processor Line Power and Frequency Specifications	95
5.2.2	Processor Line Thermal and Power	93
5.3	Thermal Profile for PCG 2020 Processor	124
5.3.1	Thermal Profile for PCG 2022E Processor	124
5.3.2	Thermal Profile for PCG 2020A Processor	127
5.3.3	Thermal Profile for PCG 2020C Processor	129
5.3.4	Thermal Profile for PCG 2020D Processor	131
5.4	Thermal Metrology	133
5.5	Fan Speed Control Scheme with DTS	134
6.	Memory	139
6.1	System Memory Interface	140
6.1.1	Processor SKU Support Matrix	140
6.1.2	Supported Memory Modules and Devices	143
6.1.3	System Memory Timing Support	152
6.1.3.1	System Memory Timing Support	152
6.1.3.2	SAGV Points	153
6.1.3.3	DDR Frequency Shifting	155
6.1.4	Memory Controller (MC)	156
6.1.5	Memory Controller Power Gate	156
6.1.6	System Memory Controller Organization Mode (DDR4/5 Only)	156
6.1.7	System Memory Frequency	158
6.1.8	Technology Enhancements of Intel® Fast Memory Access (Intel® FMA)	158
6.1.9	Data Scrambling	158
6.1.10	Data Swapping	159
6.1.11	LPDDR5/x Ascending and Descending	159
6.1.12	LPDDR4x CMD Mirroring	160
6.1.13	DDR I/O Interleaving	160
6.1.14	DRAM Clock Generation	162
6.1.15	DRAM Reference Voltage Generation	162
6.1.16	Data Swizzling	162
6.1.17	Error Correction With Standard RAM	162
6.1.18	Post Package Repair (PPR)	162
6.2	Integrated Memory Controller (IMC) Power Management	163
6.2.1	Disabling Unused System Memory Outputs	163
6.2.2	DRAM Power Management and Initialization	163
6.2.2.1	Initialization Role of CKE	164
6.2.2.2	Conditional Self-Refresh	164
6.2.2.3	Dynamic Power-Down	165
6.2.2.4	DRAM I/O Power Management	165
6.2.3	DDR Electrical Power Gating	165
6.2.4	Power Training	165
7.	USB-C* Sub System	165

7.1	General Capabilities	166
7.2	USB™ 4 Router	169
7.2.1	USB 4 Host Router Implementation Capabilities	170
7.3	USB-C Sub-system xHCI/xDCI Controllers	170
7.3.1	USB 3 Controllers	170
7.3.1.1	Extensible Host Controller Interface (xHCI)	171
7.3.1.2	Extensible Device Controller Interface (xDCI)	171
7.3.2	USB-C Sub-System PCIe Interface	171
7.4	USB-C Sub-System Display Interface	171
8.	PCIe* Interface	172
8.1	Processor PCI Express* Interface	172
8.1.1	PCI Express* Support	172
8.1.2	PCI Express* Architecture	177
8.1.3	PCI Express* Configuration Mechanism	178
8.1.4	PCI Express* Equalization Methodology	178
8.1.5	PCI Express* Hot Plug	179
9.	Direct Media Interface and On Package Interface	179
9.1	Direct Media Interface (DMI)	179
9.1.1	DMI Lane Reversal and Polarity Inversion	179
9.1.2	DMI Error Flow	180
9.1.3	DMI Link Down	180
9.2	On Package Interface (OPI)	180
9.2.1	OPI Support	180
9.2.2	Functional Description	181
10.	Graphics	181
10.1	Processor Graphics	181
10.1.1	Media Support (Intel® QuickSync and Clear Video Technology HD)	181
10.1.1.1	Hardware Accelerated Video Decode	181
10.1.1.2	Hardware Accelerated Video Encode	183
10.1.1.3	Hardware Accelerated Video Processing	184
10.1.1.4	Hardware Accelerated Transcoding	184
10.2	Platform Graphics Hardware Feature	185
10.2.1	Hybrid Graphics	185
11.	Display	185
11.1	Display Technologies Support	185
11.2	Display Configuration	186
11.3	Display Features	190
11.3.1	General Capabilities	190
11.3.2	Multiple Display Configurations	191
11.3.3	High-bandwidth Digital Content Protection (HDCP)	191
11.3.4	DisplayPort*	191

11.3.4.1 Multi-Stream Transport (MST)	192
11.3.5 High-Definition Multimedia Interface (HDMI*)	195
11.3.6 embedded DisplayPort* (eDP*)	197
11.3.7 MIPI* DSI	198
11.3.8 Integrated Audio	199
12. Camera/MIPI	200
12.1 Camera Pipe Support	200
12.2 MIPI* CSI-2 Camera Interconnect	201
12.2.1 Camera Control Logic	201
12.2.2 Camera Modules	201
12.2.3 CSI-2 Lane Configuration	201
13. Signal Description	202
13.1 System Memory Interface	204
13.1.1 DDR4 Memory Interface	204
13.1.2 LP4x-LP5 Memory Interface	214
13.1.3 DDR5 Memory Interface	218
13.2 PCI Express* Graphics (PEG) Signals	221
13.3 Direct Media Interface (DMI) Signals	223
13.4 Reset and Miscellaneous Signals	224
13.5 Display Interfaces	228
13.5.1 Digital Display Interface (DDI) Signals	228
13.5.2 Digital Display Audio Signals	229
13.6 USB Type-C Signals	229
13.7 MIPI* CSI-2 Interface Signals	231
13.8 Processor Clocking Signals	233
13.9 Testability Signals	233
13.10 Error and Thermal Protection Signals	236
13.11 Power Sequencing Signals	238
13.12 Processor Power Rails	240
13.13 Ground and Reserved Signals	244
13.14 Processor Internal Pull-Up / Pull-Down Terminations	245
14. Electrical Specifications	245
14.1 Processor Power Rails	245
14.1.1 Power and Ground Pins	247
14.1.2 Voltage Regulator	247
14.1.3 VCC Voltage Identification (VID)	247
14.2 DC Specifications	248
14.2.1 Processor Power Rails DC Specifications	248
14.2.1.1 VCCCORE DC Specifications	248
14.2.1.2 VccGT DC Specifications	265
14.2.1.3 VccSA DC Specifications	270

14.2.1.4	VDD2 DC Specifications	272
14.2.1.5	VCCANA DC Specifications	274
14.2.1.6	VCC_MIPILP DC Specifications	275
14.2.1.7	Vcc1P05_PROC DC Specifications	276
14.2.1.8	Vcc1P8_PROC DC Specifications	278
14.2.2	Processor Interfaces DC Specifications	281
14.2.2.1	DDR4 DC Specifications	281
14.2.2.2	DDR5 DC Specifications	285
14.2.2.3	LPDDR4x DC Specification	289
14.2.2.4	LPDDR5 DC Specification	292
14.2.2.5	PCI Express* Graphics (PEG) Group DC Specifications	295
14.2.2.6	Digital Display Interface (DDI) DC Specifications	296
14.2.2.7	CMOS DC Specifications	299
14.2.2.8	GTL and OD DC Specification	300
14.2.2.9	PECI DC Characteristics	301
15.	Package Mechanical Specifications	303
15.1	Package Mechanical Attributes	303
15.2	Package Storage Specifications	309
16.	CPU And Device IDs	310
16.1	CPUID	310
16.2	PCI Configuration Header	312
16.3	Device IDs	313

Revision History

Document Number	Revision Number	Description	Revision Date
655258	001	Initial Release for S 125W SKUs	October 2021
655258	002	Intel® Hybrid Technology name replaced with Intel's Performance Hybrid Architecture	November 2021
655258	003	<p>Graphics</p> <ul style="list-style-type: none"> • Added the Direct3D12 Video API support and E2E playback information into the Note in Hardware Accelerated Video Decode • Updated the <ul style="list-style-type: none"> ◦ Table: Hardware Accelerated Video Decoding ◦ Intel® Media SDK to OneVPL ◦ Intel® CUI SDK to Intel® Graphics Control Library • Removed <ul style="list-style-type: none"> ◦ Note of HEVC -10 bit support in Hardware Accelerated Video Decode ◦ Image stabilization in Hardware Accelerated Video Processing <p>Signal Description</p> <ul style="list-style-type: none"> • Updated rail for BPM#[3:0] in Processor Internal Pull-Up / Pull-Down Terminations <p>Memory</p> <ul style="list-style-type: none"> • Added <ul style="list-style-type: none"> ◦ ECC note in Table: DDR Support Matrix Table ◦ Note for S 125W processors in SAGV Points <p>Thermal Management</p> <ul style="list-style-type: none"> • Updated DT new SKUs options 	December 2021

Document Number	Revision Number	Description	Revision Date
655258	004	Initial Release for H45 and S 35W, 46W, 58W, 60W, and 65W SKUs <ul style="list-style-type: none"> • Added <ul style="list-style-type: none"> ◦ Note in Intel® Multi-Key Total Memory Encryption 	January 2022
655258	005	Initial Release for U9, U15, and P SKUs	March 2022
655258	006	<p>Technologies</p> <ul style="list-style-type: none"> • Updated Intel® Performance Hybrid Architecture <p>Thermal Management</p> <ul style="list-style-type: none"> • Added <ul style="list-style-type: none"> ◦ 150W SKU information in Processor Line Power and Frequency Specifications and Processor Line Thermal and Power ◦ Thermal Profile for PCG 2022E Processor • Updated Fan Speed Control Scheme with DTS <p>Memory</p> <ul style="list-style-type: none"> • Updated Processor SKU Support Matrix <p>Electrical Specifications</p> <ul style="list-style-type: none"> • Updated CMOS DC Specifications 	April 2022
655258	007	Initial Release for HX SKUs <p>Introduction</p> <ul style="list-style-type: none"> • Updated API Support (Windows*) <p>Memory</p> <ul style="list-style-type: none"> • Updated SAGV Points <p>Electrical Specifications</p> <ul style="list-style-type: none"> • Updated Vcc1P05_PROC DC Specifications 	May 2022

Document Number	Revision Number	Description	Revision Date
655258	008	<p>Technologies</p> <ul style="list-style-type: none"> • Corrected L1 Data and Instruction Cache size in IA Cores Level 1 and Level 2 Caches <p>Electrical Specifications</p> <ul style="list-style-type: none"> • Added S 6+0 -Processor detail in VCCCORE Iccmax in DC Specifications 	June 2022
655258	009	<p>Technologies</p> <ul style="list-style-type: none"> • Updated Intel® Total Memory Encryption - Multi-Key <p>Signal Description</p> <ul style="list-style-type: none"> • Updated I/O types in LP4x-LP5 Memory Interface, DDR4 Memory Interface, and DDR5 Memory Interface 	August 2022
655258	010	<p>Introduction</p> <ul style="list-style-type: none"> • Removed 65W from HX in Table: Processor Lines <p>Thermal Management</p> <ul style="list-style-type: none"> • Updated Table: Processor Base Power (TDP) and Frequency Specifications (HX-Processor Line) <p>Package Mechanical Specifications</p> <ul style="list-style-type: none"> • Updated Table: HX BGA Processor Package Mechanical Attributes 	February 2023
655258	011	<p>Technologies</p> <ul style="list-style-type: none"> • Removed FP16 support in Intel® Performance Hybrid Architecture 	May 2025

Introduction

This processor is a 64-bit, multi-core processor built on Intel® 7 process technology.

Intel® Core™ Processors includes the Intel® Performance Hybrid architecture, P-Cores for performance and E-Cores for Efficiency. Refer to [Table: Processor Lines](#) for availability in Intel processor lines. For more details on P-Core and E-Core, refer to [Power and Performance Technologies](#).

The S-Processor Line offered in a 2-Chip Platform that includes the Processor Die in LGA package and Platform Controller Hub (PCH-S).

The HX-Processor Line offered in a 2-Chip Platform that includes the Processor Die in BGA package and Platform Controller Hub (PCH-S).

The H-Processor Line offered in a 1-Chip Platform that includes the Processor Die and Platform Controller Hub (PCH-P) die on the same package as the processor die.

The P-Processor Line and U15 processor offered in a 1-Chip Platform that includes the Processor Die Platform Controller Hub (PCH-P) die on the same package as the processor die.

The U9-Processor offered in a 1-Chip Platform that includes the Processor Die and Platform Controller Hub (PCH-M) die on the same package as the processor die.

The following table describes the different processor lines:

Processor Lines

Processor Line ¹	Package	Processor Base Power (a.k.a TDP) ^{2, 3}	Processor IA P-Cores	Processor IA E-Cores	Graphics Configuration	Platform Type
S - Processor	LGA1700	35W	8	8	32EU	2-Chip
	LGA1700	35W	8	4	32EU	2-Chip
	LGA1700	35W	6	0	25EU	2-Chip
	LGA1700	35W	6	0	24EU	2-Chip
	LGA1700	35W	4	0	24EU	2-Chip

Processor Line ¹	Package	Processor Base Power (a.k.a TDP) ^{2, 3}	Processor IA P-Cores	Processor IA E-Cores	Graphics Configuration	Platform Type
	LGA1700	35W	2	0	16EU	2-Chip
	LGA1700	46W	2	0	16EU	2-Chip
	LGA1700	58W	4	0	0EU	2-Chip
	LGA1700	60W	4	0	16EU	2-Chip
	LGA1700	65W	8	8	32EU	2-Chip
	LGA1700	65W	8	4	32EU	2-Chip
	LGA1700	65W	6	0	32EU	2-Chip
	LGA1700	65W	6	0	24EU	2-Chip
	LGA1700	65W	6	0	0 EU	2-Chip
	LGA1700	125W	8	8	32EU	2-Chip

Processor Line ¹	Package	Processor Base Power (a.k.a TDP) ^{2, 3}	Processor IA P-Cores	Processor IA E-Cores	Graphics Configuration	Platform Type
	LGA1700	125W	8	4	32EU	2-Chip
	LGA1700	125W	6	4	32EU	2-Chip
HX - Processor	BGA1964	55W	8	8	32EU	2-Chip
H - Processor	BGA1744	45W	6	8	96EU	1-Chip
	BGA1744	45W	6	4	64EU	1-Chip
	BGA1744	45W	4	8	80EU	1-Chip
	BGA1744	45W	4	4	48EU	1-Chip
P - Processor	BGA1744	28W	6	8	96EU	1-Chip
	BGA1744	28W	4	8	96EU	1-Chip
	BGA1744	28W	4	8	80EU	1-Chip

Processor Line ¹	Package	Processor Base Power (a.k.a TDP) ^{2, 3}	Processor IA P-Cores	Processor IA E-Cores	Graphics Configuration	Platform Type
	BGA1744	28W	2	8	64EU	1-Chip
U - Processor	BGA1744	15W	2	8	96EU	1-Chip
	BGA1744	15W	2	8	80EU	1-Chip
	BGA1744	15W	2	4	64EU	1-Chip
	BGA1744	15W	1	4	48EU	1-Chip
	BGA1781	9W	2	8	96EU	1-Chip
	BGA1781	9W	2	8	80EU	1-Chip
	BGA1781	9W	2	4	64EU	1-Chip
	BGA1781	9W	1	4	48EU	1-Chip

Processor Line ¹	Package	Processor Base Power (a.k.a TDP) ^{2, 3}	Processor IA P-Cores	Processor IA E-Cores	Graphics Configuration	Platform Type
<p>Notes:</p> <ol style="list-style-type: none"> Processor lines offering may change. For additional Processor Base Power (a.k.a TDP) Configurations, refer to Processor Line Power and Frequency Specifications, for adjustment to the Processor Base Power (a.k.a TDP) required to preserve base frequency associated with the sustained long-term thermal capability. Processor Base Power (a.k.a TDP) workload does not reflect I/O connectivity cases such as Thunderbolt, for power adds estimation for various I/O connectivity scenarios. 						

S Processor Line Platform Diagram

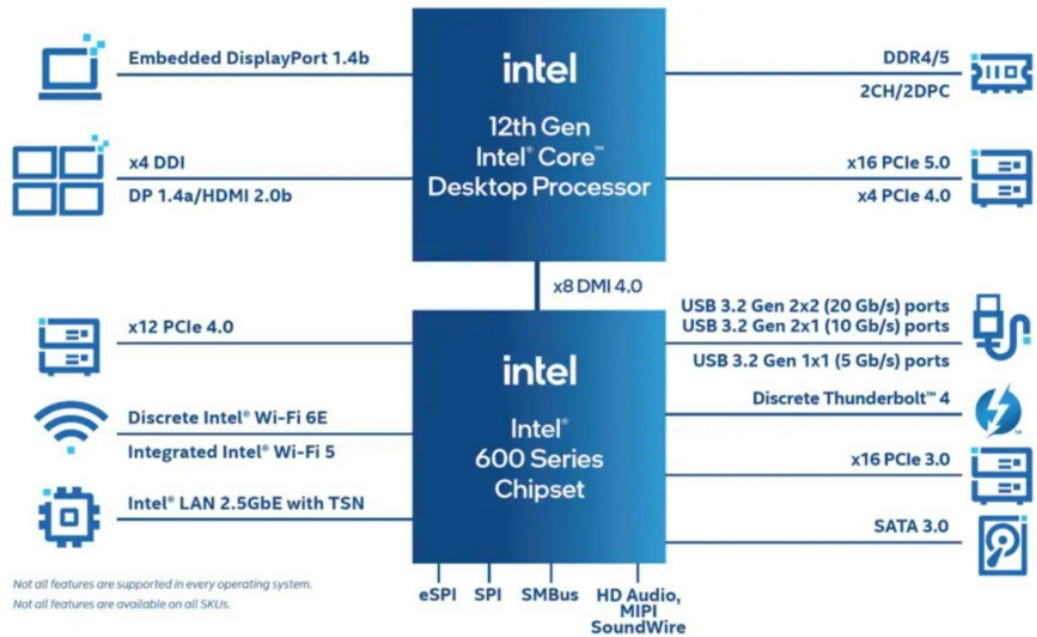

H/P Processor Line Platform Diagram

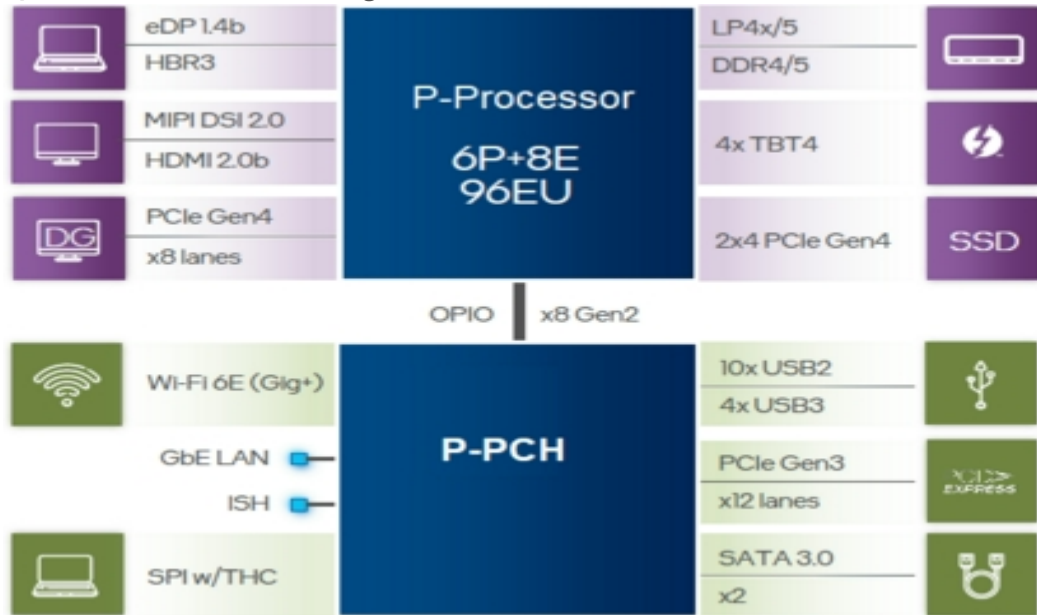

Not all processor interfaces and features are presented in all Processor Lines. The presence of various interfaces and features will be indicated within the relevant sections and tables.

Note: Throughout this document, the 12th Generation Intel® Core™ Processors may be referred to as **processor** and the Intel® 600 Series Chipset Family Platform Controller Hub may be referred to as **PCH**.

U15 Processor Line Platform Diagram

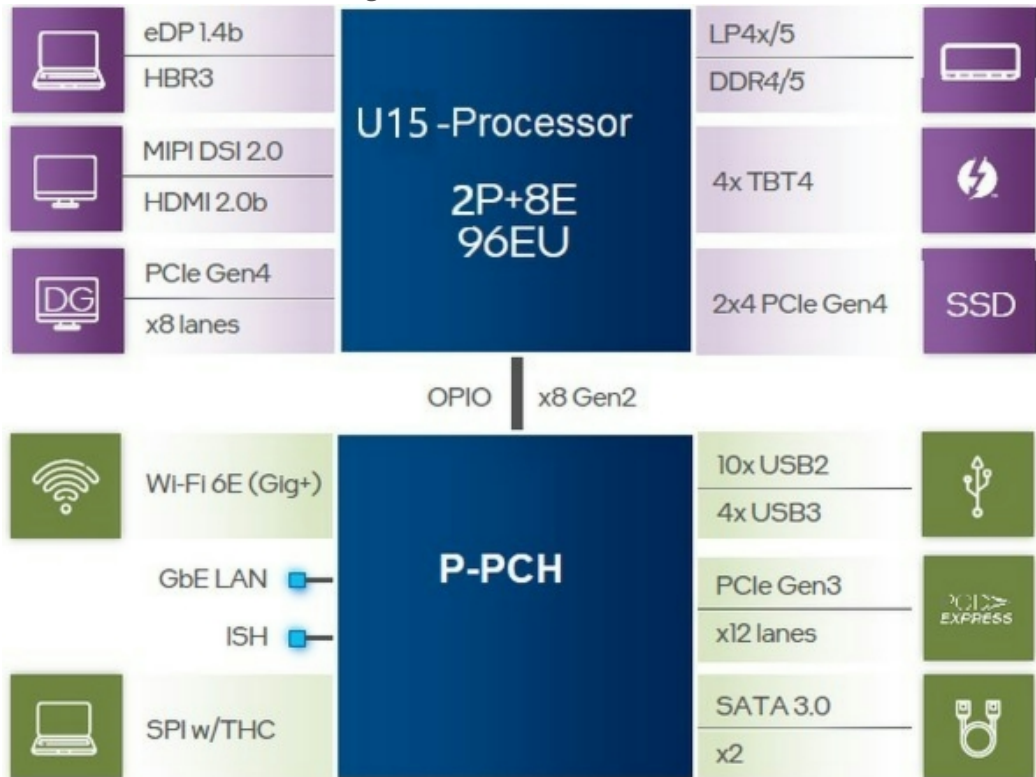

U9 Processor Line Platform Diagram

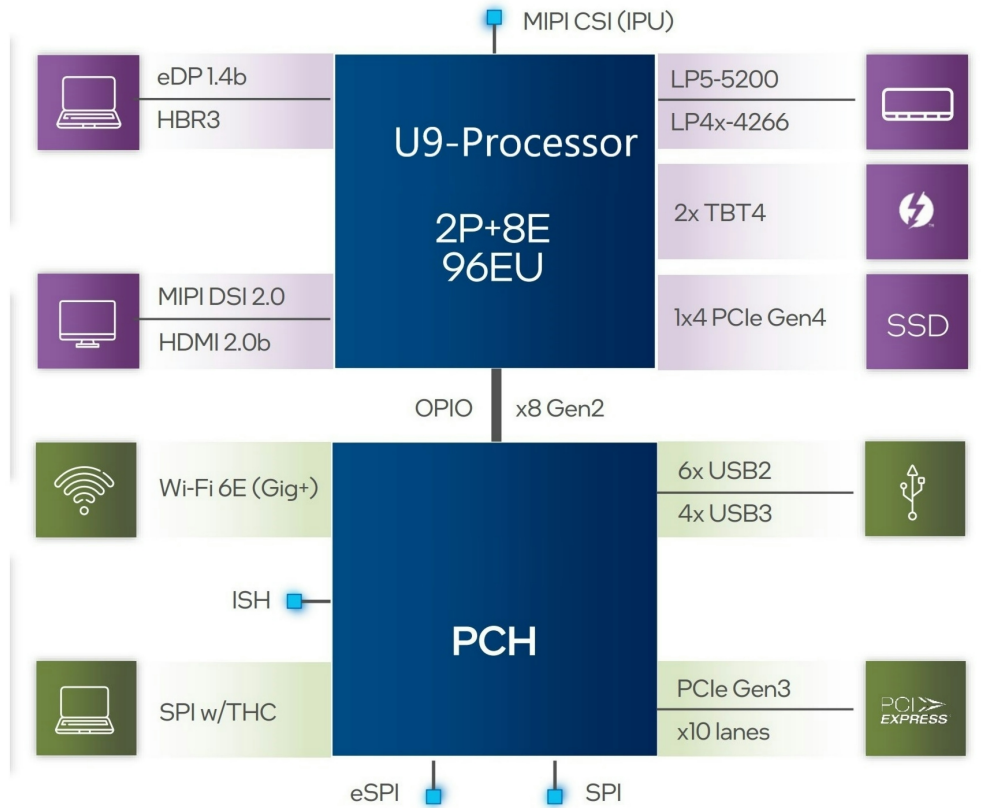

HX Processor Line Platform Diagram

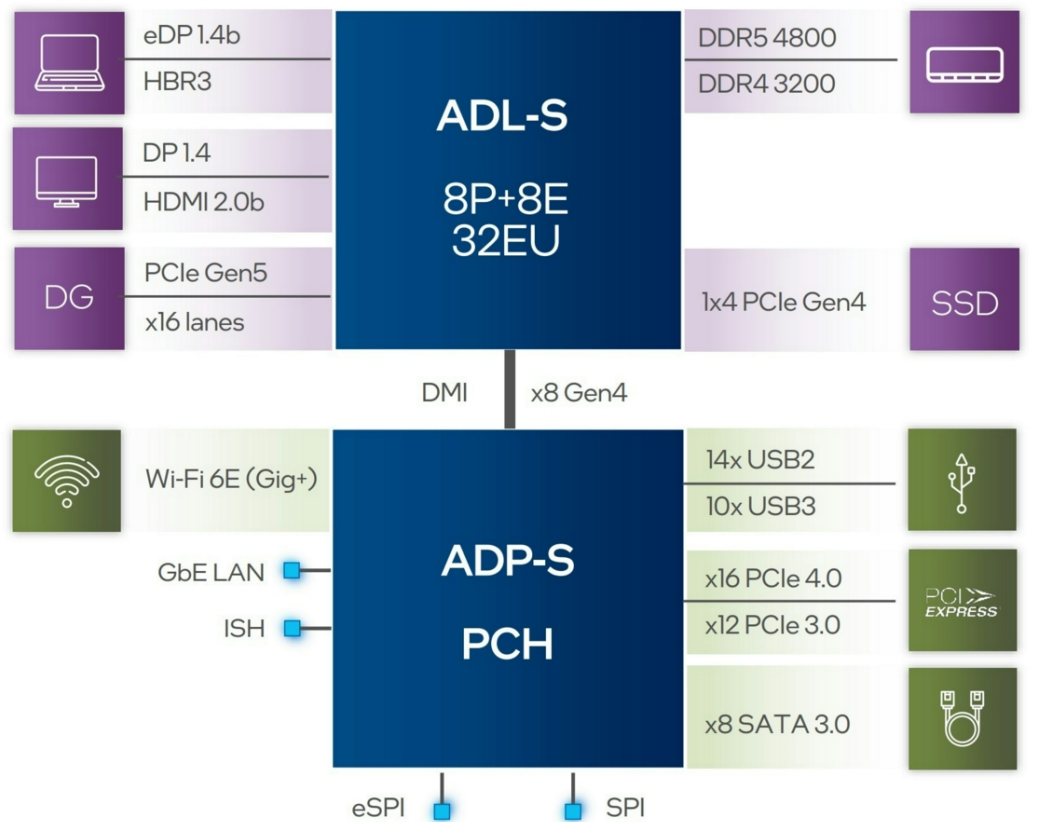

Processor Volatility Statement

The processor families do not retain any end-user data when powered down and/or when the processor is physically removed.

Note: Powered down refers to the state which all processor power rails are off.

Package Support

The S Processor lines are available in the following package:

- LGA1700
 - A 45 X 37.5 mm
 - Substrate Z=1.116 mm +/-0.95
 - Substrate + Die Z is 1.116+0.37= 1.486 mm

The HX-Processor line is available in the following packages:

- BGA1964
 - A 45 X 37.5 mm
 - Substrate Z = 1.119+/-0.095 mm
 - 2.005±0.114 (BOTTOM OF BGA TO TOP OF DIE)

The H-Processor line, P-Processor line, and U15-Processor line (U-Processor line) are available in the following packages:

- BGA1744
 - A 25 X 50 mm
- Substrate Z = 0.594+/-0.08 mm
- 1.185±0.096 (BOTTOM OF BGA TO TOP OF DIE)

The U9-Processor line (U-Processor line) is available in the following packages:

- BGA1781
 - A 19 x 28.5 mm
 - Substrate Z = 584±0.065
 - 1.033 ± 0.079 (BOTTOM OF BGA TO TOP OF DIE)

Supported Technologies

- PECl – Platform Environmental Control Interface
- Intel® Virtualization Technology (Intel® VT-x)
- Intel® Virtualization Technology for Directed I/O (Intel® VT-d)
- Intel® APIC Virtualization Technology (Intel® APICv)
- Hypervisor-Managed Linear Address Translation (HLAT)
- Intel® Trusted Execution Technology (Intel® TXT)
- Intel® Advanced Encryption Standard New Instructions (Intel® AES-NI)
- PCLMULQDQ (Perform Carry-Less Multiplication Quad word) Instruction
- Intel® Secure Key
- Execute Disable Bit
- Intel® Boot Guard
- SMEP – Supervisor Mode Execution Protection
- SMAP – Supervisor Mode Access Protection
- SHA Extensions – Secure Hash Algorithm Extensions
- UMIP – User Mode Instruction Prevention
- RDPID – Read Processor ID

- Intel® Total Memory Encryption (Intel® TME)
- Intel® Control-flow Enforcement Technology (Intel® CET)
- KeyLocker Technology
- Devils gate Rock (DGR)
- Smart Cache Technology
- IA Core Level 1 and Level 2 Caches
- Intel's Performance Hybrid Architecture
- Intel® Turbo Boost Technology 2.0
- Intel® Turbo Boost Max Technology 3.0
- PAIR – Power Aware Interrupt Routing
- Intel® Hyper-Threading Technology (Intel® HT Technology)
- Intel SpeedStep® Technology
- Intel® Speed Shift Technology
- Intel® Advanced Vector Extensions 2 (Intel® AVX2)
- Intel® AVX2 Vector Neural Network Instructions (Intel® AVX2 VNNI)
- Intel® 64 Architecture x2APIC
- Intel® Dynamic Tuning technology (Intel® DTT)
- Intel® GNA 3.0 (GMM and Neural Network Accelerator)
- Intel® Image Processing Unit (Intel® IPU)
- Cache Line Write Back (CLWB)
- Intel® Processor Trace
- Platform CrashLog
- Telemetry Aggregator
- Integrated Reference Clock PLL

Note: The availability of the features above may vary between different processor SKUs. Refer to [Technologies](#) for more information.

API Support (Windows*)

- Direct3D* 2015, Direct3D 12, Direct3D 11.2, Direct3D 11.1, Direct3D 9, Direct3D 10, Direct2D
- OpenGL* 4.5
- Open CL* 2.1, Open CL* 2.0, Open CL* 1.2, Open CL* 3.0

DirectX* extensions:

- PixelSync, Instant Access, Conservative Rasterization, Render Target Reads, Floating-point De-norms, Shared a Virtual memory, Floating Point atomics, MSAA sample-indexing, Fast Sampling (Coarse LOD), Quilted Textures, GPU Enqueue Kernels, GPU Signals processing unit. Other enhancements include color compression.

architecture delivers hardware acceleration of Direct X* 12 Render pipeline comprising of the following stages: Vertex Fetch, Vertex Shader, Hull Shader, Tessellation, Domain Shader, Geometry Shader, Rasterizer, Pixel Shader, Pixel Output.

Power Management Support

Processor Core Power Management

- Full support of ACPI C-states as implemented by the following processor C-states:
 - C0, C1, C1E, C6, C8, C10
- Enhanced Intel SpeedStep® Technology
- Intel® Speed Shift Technology

Refer to [Processor IA Core Power Management](#) for more information.

System Power Management

	S - Processor	HX - Processor	H - Processor	P - Processor	U (15W) - Processor	U (9W) - Processor
12 th Generation Intel® Core™ Processors	MS and S3	MS ¹ and S3	MS and S3	MS	MS	MS
Notes: 1. Modern Standby						

Refer to [Power Management](#) for more information.

Memory Controller Power Management

- Disabling Unused System Memory Outputs
- DRAM Power Management and Initialization
- Initialization Role of CKE
- Conditional Self-Refresh
- Dynamic Power Down
- DRAM I/O Power Management
- DDR Electrical Power Gating (EPG)
- Power Training

Refer to [Integrated Memory Controller \(IMC\) Power Management](#) for more information

Processor Graphics Power Management

Memory Power Savings Technologies

- Intel® Rapid Memory Power Management (Intel® RMPM)
- Intel® Smart 2D Display Technology (Intel® S2DDT)

Display Power Savings Technologies

- Intel® (Seamless and Static) Display Refresh Rate Switching (DRRS) with eDP* port
- Intel® OLED Power Saving Technology (Intel® OPST) 1.1
- Intel® Display Power Saving Technology (Intel® DPST 7.0)
- Panel Self-Refresh 2 (PSR 2)
- Low-Power Single Pipe (LPSP)
- Low-Power Dual Pipe (LPDP)

Graphics Core Power Savings Technologies

- Graphics Dynamic Frequency
- Intel® Graphics Render Standby Technology (Intel® GRST)
- Intel Capped Frames Per Second (CFPS)

Thermal Management Support

- Digital Thermal Sensor
- Intel® Adaptive Thermal Monitor
- THERMTRIP# and PROCHOT# support
- On-Demand Mode
- Memory Thermal Throttling
- External Thermal Sensor (TS-on-DIMM and TS-on-Board)

- Render Thermal Throttling
- Fan Speed Control with DTS
- Intel® Turbo Boost Technology 2.0 Power Control
- Intel® Dynamic Tuning technology (Intel® DTT)

Refer to [Thermal Management](#) for more information.

Ball-out Information

For information on the ballout of S/S Refresh download the pdf, click



on the navigation pane and refer the spreadsheet, [655258-001_S_LGA_Ballout.xlsx](#).

For information on the S BGA processor ballout, download the pdf, click

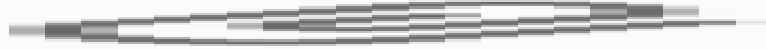

on the navigation pane and refer the spreadsheet [655258-001_S_BGA_Ballout.xlsx](#)

For information on the H and P and U15 ballout, download the pdf, click

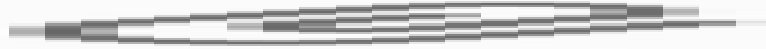

on the navigation pane and refer the spreadsheet [655258-001_H_P_Ballout.xlsx](#)

For information on the U9 ballout, download the pdf, click

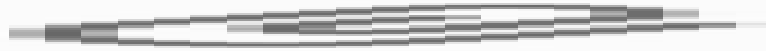

on the navigation pane and refer the spreadsheet [655258-001_U9_Ballout.xlsx](#)

Processor Testability

A DCI on-board connector should be placed, to enable 12th Generation Intel® Core™ full debug capabilities.

For 12th Generation Intel® Core™ processor lines, a Direct Connect Interface Tool connector is highly recommended to enable lower C-state to debug.

The processor includes boundary-scan for board and system level testability.

Operating Systems Support

Processor Line	Windows* 11 / Windows 20H2	Linux* OS	Chrome* OS
S-Processor Line	Yes	Yes	No
HX-Processor Line	Yes	Yes	No
H-Processor Line	Yes	Yes	Yes
P-Processor Line	Yes	Yes	Yes
U-Processor Line	Yes	Yes	Yes

Note:
Refer to OS vendor site for more information regarding latest OS revision support.

Terminology and Special Marks

Terminology

Term	Description
4K	Ultra High Definition (UHD)
AES	Advanced Encryption Standard
AGC	Adaptive Gain Control
API	Application Programming Interface

Term	Description
AVC	Advanced Video Coding
BLT	Block Level Transfer
BPP	Bits per Pixel
CDR	Clock and Data Recovery
CTLE	Continuous Time Linear Equalizer
DDC	Digital Display Channel (Refer to Intel® 600 Series Chipset Family Platform Controller Hub Datasheet Volume 1 of 2 (#648364) for more details)
DDI	Digital Display Interface for DP or HDMI/DVI
DSI	Display Serial Interface
DDR4	Fourth-Generation Double Data Rate SDRAM Memory Technology
DDR5	Fifth-Generation Double Data Rate SDRAM Memory Technology
DPC	DIMM per channel
DFE	Decision Feedback Equalizer
DMA	Direct Memory Access
DPPM	Dynamic Power Performance Management

Term	Description
DMI	Direct Media Interface
DP*	DisplayPort*
DSC	Display Stream Compression
DSI	Display Serial Interface
DTS	Digital Thermal Sensor
ECC	Error Correction Code - used to fix DDR transactions errors
eDP*	Embedded DisplayPort*
EU	Execution Unit in the Graphics Processor
FIVR	Fully Integrated Voltage Regulator
GSA	Graphics in System Agent
GNA	Gauss Newton Algorithm
HDCP	High-Bandwidth Digital Content Protection
HDMI*	High Definition Multimedia Interface
IMC	Integrated Memory Controller

Term	Description
Intel® 64 Technology	64-bit memory extensions to the IA-32 architecture
Intel® DPST	Intel® Display Power Saving Technology
Intel® PTT	Intel® Platform Trust Technology
Intel® TXT	Intel® Trusted Execution Technology
Intel® VT	Intel® Virtualization Technology. Processor Virtualization, when used in conjunction with Virtual Machine Monitor software, enables multiple, robust independent software environments inside a single platform.
Intel® VT-d	Intel® Virtualization Technology (Intel® VT) for Directed I/O. Intel® VT-d is a hardware assist, under system software (Virtual Machine Manager or OS) control, for enabling I/O device Virtualization. Intel® VT-d also brings robust security by providing protection from errant DMAs by using DMA remapping, a key feature of Intel® VT-d.
ITH	Intel® Trace Hub
IOV	I/O Virtualization
IPU	Image Processing Unit
LFM	Low Frequency Mode. corresponding to the Enhanced Intel SpeedStep® Technology's lowest voltage/frequency pair. It can be read at MSR CEh [47:40].
LLC	Last Level Cache
LPDDR4x/5	Low Power Double Data Rate SDRAM memory technology /x- additional power save.

Term	Description
LPSP	Low-Power Single Pipe
LSF	Lowest Supported Frequency. This frequency is the lowest frequency where manufacturing confirms logical functionality under the set of operating conditions.
LTR	The Latency Tolerance Reporting (LTR) mechanism enables Endpoints to report their service latency requirements for Memory Reads and Writes to the Root Complex, so that power management policies for central platform resources (such as main memory, RC internal interconnects, and snoop resources) can be implemented to consider Endpoint service requirements.
MCP	Multi-Chip Package - includes the processor and the PCH. In some SKUs, it might have additional On-Package Cache.
MFM	Minimum Frequency Mode. MFM is the minimum ratio supported by the processor and can be read from MSR CEh [55:48].
MLC	Mid-Level Cache
MPEG	Motion Picture Expert Group, international standard body JTC1/SC29/WG11 under ISO/IEC that has defined audio and video compression standards such as MPEG-1, MPEG-2, and MPEG-4, etc.
NCTF	Non-Critical to Function. NCTF locations are typically redundant ground or non-critical reserved balls/lands, so the loss of the solder joint continuity at end of life conditions will not affect the overall product functionality.
PCH	Platform Controller Hub. The chipset with centralized platform capabilities including the main I/O interfaces along with display connectivity, audio features, power management, manageability, security, and storage features. The PCH may also be referred to as "chipset".
PECI	Platform Environment Control Interface

Term	Description
PEG	PCI Express* Graphics
PL1, PL2, PL3	Power Limit 1, Power Limit 2, Power Limit 3
PMIC	Power Management Integrated Circuit
Processor	The 64-bit multi-core component (package)
Processor Core	The term “processor core” refers to the Si die itself, which can contain multiple execution cores. Each execution core has an instruction cache, data cache, and 256-KB L2 cache. All execution cores share the LLC.
Processor Graphics	Intel® Processor Graphics
PSR	Panel Self-Refresh
PSx	Power Save States (PS0, PS1, PS2, PS3, PS4)
Rank	A unit of DRAM corresponding to four to eight devices in parallel, ignoring ECC. These devices are usually, but not always, mounted on a single side of a SoDIMM.
SCI	System Control Interrupt. SCI is used in the ACPI protocol.
SDP	Scenario Design Power
SHA	Secure Hash Algorithm
SSC	Spread Spectrum Clock

Term	Description
Storage Conditions	Refer Package Storage Specifications .
STR	Suspend to RAM
TAC	Thermal Averaging Constant
TBT	Thunderbolt™ Interface
TCC	Thermal Control Circuit
Processor Base Power (a.k.a TDP)	Thermal Design Power
TTV Processor Base Power (a.k.a TDP)	Thermal Test Vehicle TDP
V _{CC}	Processor Core Power Supply
V _{CCGT}	Processor Graphics Power Supply
V _{CCSA}	System Agent Power Supply
VLD	Variable Length Decoding
VPID	Virtual Processor ID
V _{SS}	Processor Ground

Term	Description
D0ix-states	USB controller power states ranging from D0i0 to D0i3, where D0i0 is fully powered on and D0i3 is primarily powered off. Controlled by SW.
S0ix-states	Processor residency idle standby power states.

Special Marks

Mark	Definition
[]	Brackets ([]) sometimes follow a ball, pin, registers or a bit name. These brackets enclose a range of numbers, for example, TCP[2:0]_TXRX_P[1:0] may refer to four USB-C* pins or EAX[7:0] may indicate a range that is 8 bits length.
_N / # / B	A suffix of _N or # or B indicates an active low signal. For example, CATERR#_N does not refer to a differential pair of signals such as CLK_P, CLK_N
0x000	Hexadecimal numbers are identified with an x in the number. All numbers are decimal (base 10) unless otherwise specified. Non-obvious binary numbers have the 'b' enclosed at the end of the number. For example, 0101b

Related Documents

Document	Document Number
Intel® 600 Series Chipset Family Platform Controller Hub Datasheet, Volume 1 of 2	648364
Intel® 600 Series Chipset Family Platform Controller Hub (PCH) Datasheet - Volume 2 of 2	680836

Document	Document Number
12 th Generation Intel® Core™ Processors Datasheet Volume 2a of 2	655259

Technologies

This chapter provides a high-level description of Intel technologies implemented in the processor.

The implementation of the features may vary between the processor SKUs.

Details on the different technologies of Intel processors and other relevant external notes are located at the Intel technology web site: <http://www.intel.com/technology/>

Note: The last section of this chapter is dedicated to deprecated technologies. These technologies are not supported in this processor but were supported in previous generations.

Platform Environmental Control Interface

Platform Environmental Control Interface (PECI) is an Intel proprietary interface that provides a communication channel between Intel processors and external components such as Super IO (SIO) and Embedded Controllers (EC) to provide processor temperature, Turbo, Assured Power (cTDP), and Memory Throttling Control mechanisms and many other services. PEFI is used for platform thermal management and real-time control and configuration of processor features and performance.

Note:

- PEFI over eSPI is supported.

PECI Bus Architecture

The PEFI architecture is based on a wired-OR bus that the clients (as processor PEFI) can pull up (with the strong drive).

The idle state on the bus is '0' (logical low) and near zero (Logical voltage level).

Note: PEFI supported frequency range is 3.2 kHz - 1 MHz.

The following figures demonstrate PEFI design and connectivity:

- PECL Host-Clients Connection: While the host/originator can be third party PECL host and one of the PECL client is a processor PECL device.
- PECL EC Connection.

Example for PECL Host-Clients Connection

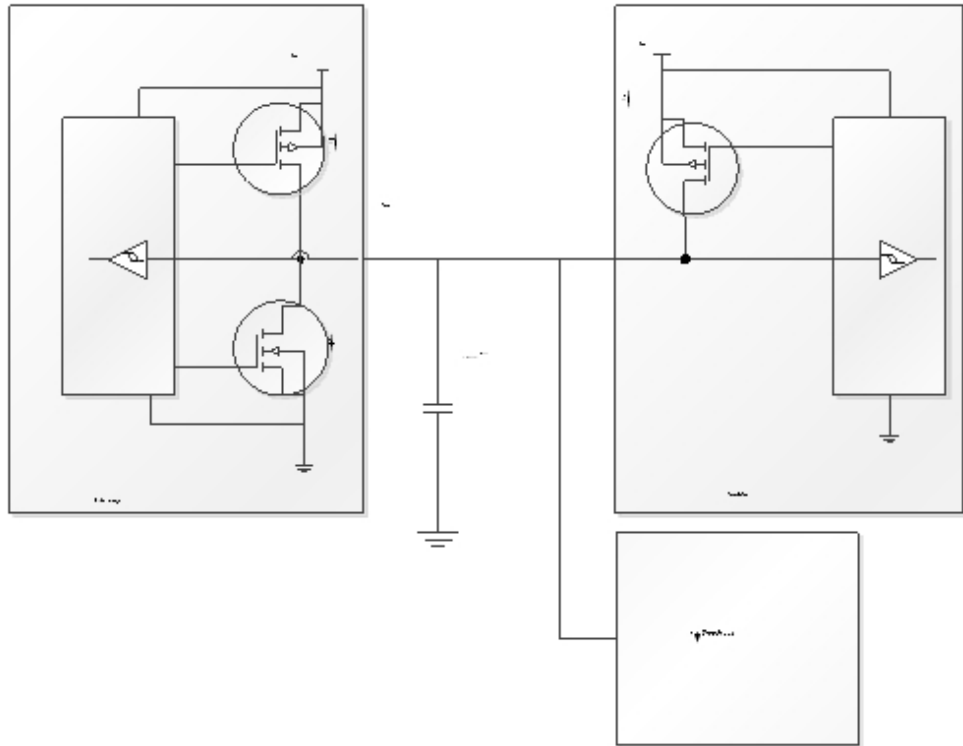

Example for PECEC Connection

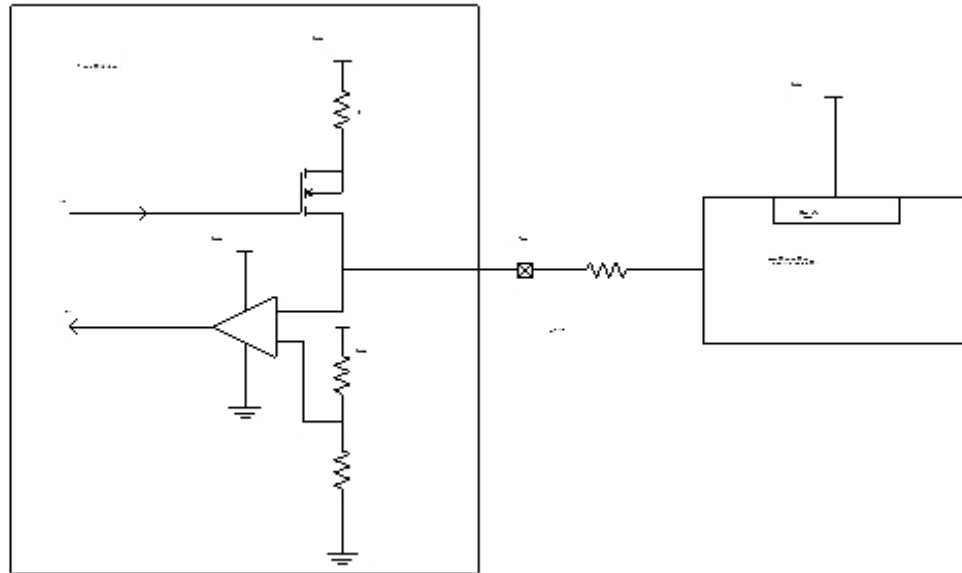

Intel® Virtualization Technology

Intel® Virtualization Technology (Intel® VT) makes a single system appear as multiple independent systems to software. This allows multiple, independent operating systems to run simultaneously on a single system. Intel® VT comprises technology components to support Virtualization of platforms based on Intel® architecture microprocessors and chipsets.

Intel® Virtualization Technology (Intel® VT) Intel® 64 and Intel® Architecture (Intel® VT-x) added hardware support in the processor to improve the Virtualization performance and robustness. Intel® Virtualization Technology for Directed I/O (Intel® VT-d) extends Intel® VT-x by adding hardware assisted support to improve I/O device Virtualization performance.

Intel® VT-x specifications and functional descriptions are included in the *Intel® 64 Architectures Software Developer's Manual, Volume 3*. Available at:

<http://www.intel.com/products/processor/manuals>

The Intel® VT-d specification and other VT documents can be referenced at:

<http://www.intel.com/content/www/us/en/virtualization/virtualization-technology/>.

Intel® VT for Intel® 64 and Intel® Architecture

Objectives

Intel® Virtualization Technology for Intel® 64 and Intel® Architecture (Intel® VT-x) provides hardware acceleration for virtualization of IA platforms. Virtual Machine Monitor (VMM) can use Intel® VT-x features to provide an improved reliable Virtualization platform. By using Intel® VT-x,

a VMM is:

- **Robust:** VMMs no longer need to use para-virtualization or binary translation. This means that VMMs will be able to run off-the-shelf operating systems and applications without any special steps.
- **Enhanced:** Intel® VT enables VMMs to run 64-bit guest operating systems on IA x86 processors.
- **More Reliable:** Due to the hardware support, VMMs can now be smaller, less complex, and more efficient. This improves reliability and availability and reduces the potential for software conflicts.
- **More Secure:** The use of hardware transitions in the VMM strengthens the isolation of VMs and further prevents corruption of one VM from affecting others on the same system.

Key Features

The processor supports the following added new Intel® VT-x features:

- **Mode-based Execute Control for EPT (MBEC)** - A mode of EPT operation which enables different controls for executability of Guest Physical Address (GPA) based on Guest specified mode (User/ Supervisor) of linear address translating to the GPA. When the mode is enabled, the executability of a GPA is defined by two bits in EPT entry. One bit for accesses to user pages and other one for accesses to supervisor pages.
 - This mode requires changes in VMCS and EPT entries. VMCS includes a bit "Mode-based execute control for EPT" which is used to enable/disable the mode. An additional bit in EPT entry is defined as "execute access for user-mode linear addresses"; the original EPT execute access bit is considered as "execute access for supervisor-mode linear addresses". If the "mode-based execute control for EPT" VM-execution control is disabled the additional bit is ignored and the system work with one bit i.e. the original bit, for execute control for both user and supervisor pages.
 - Behavioral changes - Behavioral changes are across three areas:
 - **Access to GPA** - If the "Mode-based execute control for EPT" VMexecution control is 1, treatment of guest-physical accesses by instruction fetches depends on the linear address from which an instruction is being fetched.
 1. If the translation of the linear address specifies user mode (the U/S bit was set in every paging structure entry used to translate the linear address), the resulting guest-physical address is executable under EPT only if the XU bit (at position 10) is set in every EPT paging-structure entry used to translate the guest-physical address.
 2. If the translation of the linear address specifies supervisor mode (the U/ S bit was clear in at least one of the paging-structure entries used to translate the linear address), the resulting guest-physical address is executable under EPT only if the XS bit is set in every EPT paging-structure entry used to translate the guest-physical address.
 - The XU and XS bits are used only when translating linear addresses for guest code fetches. They do not apply to guest page walks, data accesses, or A/D-bit updates.

- **VMEntry** - If the "activate secondary controls" and "Mode-based execute control for EPT" VM-execution controls are both 1, VM entries ensure that the "enable EPT" VM-execution control is 1. VM entry fails if this check fails. When such a failure occurs, control is passed to the next instruction.
- **VMExit** - The exit qualification due to EPT violation reports clearly whether the violation was due to User mode access or supervisor mode access.
 - Capability Querying: IA32_VMX_PROCBASED_CTLX2 has bit to indicate the capability, RDMSR can be used to read and query whether the processor supports the capability or not.
- Extended Page Table (EPT) Accessed and Dirty Bits
 - EPT A/D bits enabled VMMs to efficiently implement memory management and page classification algorithms to optimize VM memory operations, such as de-fragmentation, paging, live migration, and check-pointing. Without hardware support for EPT A/D bits, VMMs may need to emulate A/D bits by marking EPT paging-structures as not-present or read-only, and incur the overhead of EPT page-fault VM exits and associated software processing.
- EPTP (EPT pointer) switching
 - EPTP switching is a specific VM function. EPTP switching allows guest software (in VMX non-root operation, supported by EPT) to request a different EPT paging-structure hierarchy. This is a feature by which software in VMX non-root operation can request a change of EPTP without a VM exit. The software will be able to choose among a set of potential EPTP values determined in advance by software in VMX root operation.
- Pause loop exiting
 - Support VMM schedulers seeking to determine when a virtual processor of a multiprocessor virtual machine is not performing useful work. This situation may occur when not all virtual processors of the virtual machine are currently scheduled and when the virtual processor in question is in a loop involving the PAUSE instruction. The new feature allows detection of such loops and is thus called PAUSE-loop exiting.

The processor IA core supports the following Intel® VT-x features:

- Extended Page Tables (EPT)
 - EPT is hardware assisted page table virtualization
 - It eliminates VM exits from guest OS to the VMM for shadow page-table maintenance
- Virtual Processor IDs (VPID)
 - Ability to assign a VM ID to tag processor IA core hardware structures (such as TLBs)
 - This avoids flushes on VM transitions to give a lower-cost VM transition time and an overall reduction in virtualization overhead.
- Guest Preemption Timer
 - The mechanism for a VMM to preempt the execution of a guest OS after an amount of time specified by the VMM. The VMM sets a timer value before entering

a guest

- The feature aids VMM developers in flexibility and Quality of Service (QoS) guarantees
- Descriptor-Table Exiting
 - Descriptor-table exiting allows a VMM to protect a guest OS from internal (malicious software based) attack by preventing the relocation of key system data structures like IDT (interrupt descriptor table), GDT (global descriptor table), LDT (local descriptor table), and TSS (task segment selector).
 - A VMM using this feature can intercept (by a VM exit) attempts to relocate these data structures and prevent them from being tampered by malicious software.

Intel® Virtualization Technology for Directed I/O

Intel® VT-d Objectives

The key Intel® Virtualization Technology (Intel® VT) for Directed I/O (Intel® VT-d) objectives are domain-based isolation and hardware-based virtualization. A domain can be abstractly defined as an isolated environment in a platform to which a subset of host physical memory is allocated. Intel® VT-d provides accelerated I/O performance for a Virtualization platform and provides software with the following capabilities:

- **I/O Device Assignment and Security:** for flexibly assigning I/O devices to VMs and extending the protection and isolation properties of VMs for I/O operations.
- **DMA Remapping:** for supporting independent address translations for Direct Memory Accesses (DMA) from devices.
- **Interrupt Remapping:** for supporting isolation and routing of interrupts from devices and external interrupt controllers to appropriate VMs.
- **Reliability:** for recording and reporting to system software DMA and interrupt errors that may otherwise corrupt memory or impact VM isolation.

Intel® VT-d accomplishes address translation by associating transaction from a given I/O device to a translation table associated with the Guest to which the device is assigned. It does this by means of the data structure in the following illustration. This table creates an association between the device's PCI Express* Bus/Device/Function (B/D/F) number and the base address of a translation table. This data structure is populated by a VMM to map devices to translation tables in accordance with the device assignment restrictions above and to include a multi-level translation table (VT-d Table) that contains Guest specific address translations.

Device to Domain Mapping Structures

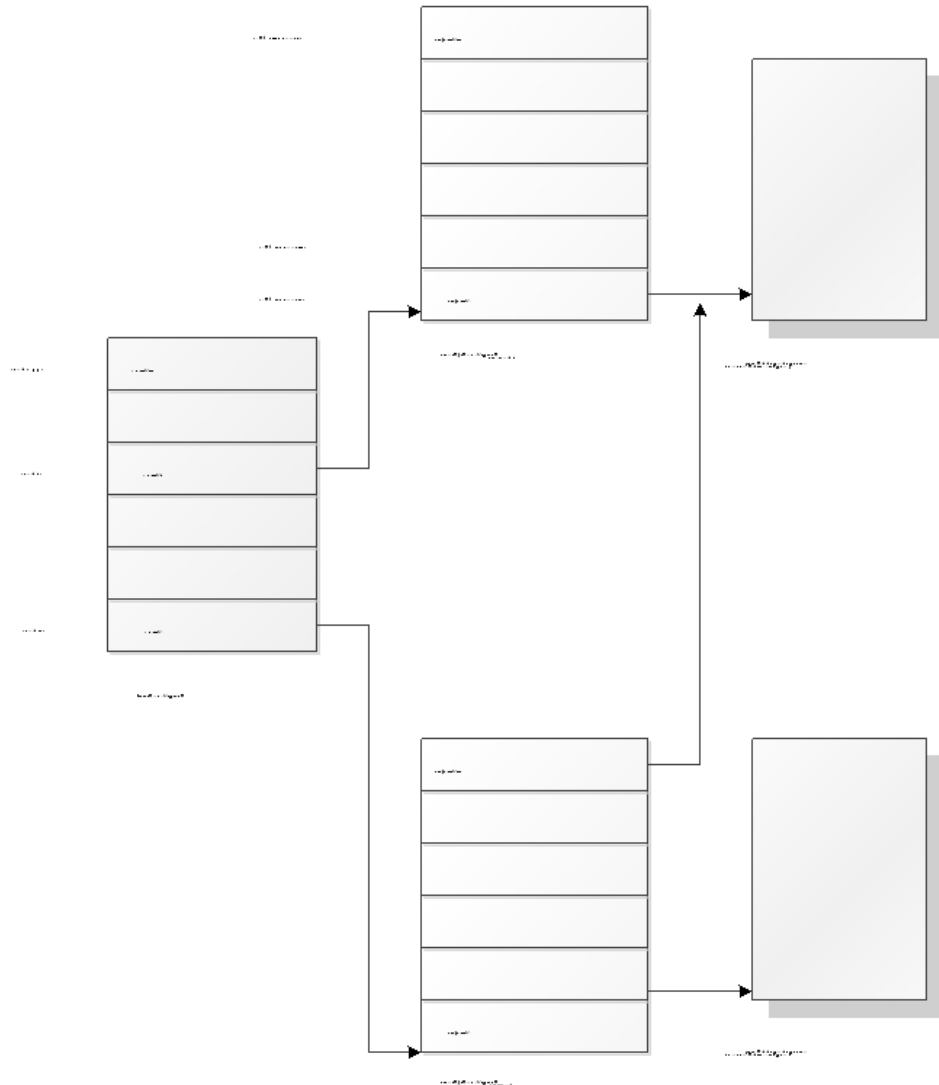

Intel® VT-d functionality often referred to as an Intel® VT-d Engine, has typically been implemented at or near a PCI Express* host bridge component of a computer system. This might be in a chipset component or in the PCI Express functionality of a processor with integrated I/O. When one such VT-d engine receives a PCI Express transaction from a PCI Express bus, it uses the B/D/F number associated with the transaction to search for an Intel® VT-d translation table. In doing so, it uses the B/D/F number to traverse the data structure shown in the above figure. If it finds a valid Intel® VT-d table in this data structure, it uses that table to translate the address provided on the PCI Express bus. If it does not find a valid translation table for a given translation, this results in an Intel® VT-d fault. If Intel® VT-d translation is required, the Intel® VT-d engine performs an N-level table walk.

For more information, refer to *Intel® Virtualization Technology for Directed I/O Architecture Specification* <http://www.intel.com/content/dam/www/public/us/en/documents/product-specifications/vt-directed-io-spec.pdf>

Intel® VT-d Key Features

The processor supports the following Intel® VT-d features:

- Memory controller and processor graphics comply with the Intel® VT-d 2.1 Specification.
- Two Intel® VT-d DMA remap engines.
 - iGFX DMA remap engine
 - Default DMA remap engine (covers all devices except iGFX)
- Support for root entry, context entry, and the default context
- 46-bit guest physical address and host physical address widths
- Support for 4K page sizes only
- Support for register-based fault recording only (for single entry only) and support for MSI interrupts for faults
- Support for both leaf and non-leaf caching
- Support for boot protection of default page table
- Support for non-caching of invalid page table entries
- Support for hardware-based flushing of translated but pending writes and pending reads, on IOTLB invalidation
- Support for Global, Domain-specific and Page specific IOTLB invalidation
- MSI cycles (MemWr to address FEE_x_xxxxh) not translated.
- Interrupt Remapping is supported
- Queued invalidation is supported
- Intel® VT-d translation bypass address range is supported (Pass Through)

The processor supports the following added new Intel® VT-d features:

- 4-level Intel® VT-d Page walk – both default Intel® VT-d engine, as well as the Processor Graphics VT-d engine are upgraded to support 4-level Intel® VT-d tables (adjusted guest address width of 48 bits)
- Intel® VT-d super-page – support of Intel® VT-d super-page (2 MB, 1 GB) for default Intel® VT-d engine (that covers all devices except IGD)
IGD Intel® VT-d engine does not support super-page and BIOS should disable super-page in default Intel® VT-d engine when iGfx is enabled.

Note: Intel® VT-d Technology may not be available on all SKUs.

Intel® APIC Virtualization Technology (Intel® APICv)

APIC virtualization is a collection of features that can be used to support the virtualization of interrupts and the Advanced Programmable Interrupt Controller (APIC).

When APIC virtualization is enabled, the processor emulates many accesses to the APIC, tracks the state of the virtual APIC, and delivers virtual interrupts — all in VMX non-root operation without a VM exit.

The following are the VM-execution controls relevant to APIC virtualization and virtual interrupts:

- **Virtual-interrupt Delivery.** This control enables the evaluation and delivery of pending virtual interrupts. It also enables the emulation of writes (memory-mapped or MSR-based, as enabled) to the APIC registers that control interrupt prioritization.
- **Use TPR Shadow.** This control enables emulation of accesses to the APIC's task-priority register (TPR) via CR8 and, if enabled, via the memory-mapped or MSR-based interfaces.
- **Virtualize APIC Accesses.** This control enables virtualization of memory-mapped accesses to the APIC by causing VM exits on accesses to a VMM-specified APIC-access page. Some of the other controls, if set, may cause some of these accesses to be emulated rather than causing VM exits.
- **Virtualize x2APIC Mode.** This control enables virtualization of MSR-based accesses to the APIC.
- **APIC-register Virtualization.** This control allows memory-mapped and MSR-based reads of most APIC registers (as enabled) by satisfying them from the virtual-APIC page. It directs memory-mapped writes to the APIC-access page to the virtual-APIC page, following them by VM exits for VMM emulation.
- **Process Posted Interrupts.** This control allows software to post virtual interrupts in a data structure and send a notification to another logical processor; upon receipt of the notification, the target processor will process the posted interrupts by copying them into the virtual-APIC page.

Note: Intel® APIC Virtualization Technology may not be available on all SKUs.

Intel® APIC Virtualization specifications and functional descriptions are included in the *Intel® 64 Architectures Software Developer's Manual, Volume 3* Available at:

<http://www.intel.com/products/processor/manuals>

Hypervisor-Managed Linear Address Translation

Hypervisor-Managed Linear Address Translation (HLAT) is active when the “enable HLAT” VM-execution control is 1. The processor looks up the HLAT if, during a guest linear address translation, the guest linear address matches the Protected Linear Range. The lookup from guest linear addresses to the guest physical address and attributes is determined by a set of HLAT paging structures.

The guest paging structure managed by the guest OS specifies the ordinary translation of a guest linear address to the guest physical address and attributes that the guest ring-0 software has programmed, whereas HLAT specifies the alternate translation of the guest linear address to guest physical address and attributes that the Secure Kernel and VMM seek to enforce. A logical processor uses HLAT to translate guest linear addresses only when those guest linear addresses are used to access memory (both for code fetch and data load/store) and the guest linear addresses match the PLR programmed by the VMM/Secure Kernel.

HLAT specifications and functional descriptions are included in the Intel® Architecture Instruction Set Extensions Programming Reference. Available at:

<https://software.intel.com/en-us/download/intel-architecture-instruction-set-extensions-programming-reference>

Security Technologies

Intel® Trusted Execution Technology

Intel® Trusted Execution Technology (Intel® TXT) defines platform-level enhancements that provide the building blocks for creating trusted platforms.

The Intel® TXT platform helps to provide the authenticity of the controlling environment such that those wishing to rely on the platform can make an appropriate trust decision. The Intel® TXT platform determines the identity of the controlling environment by accurately measuring and verifying the controlling software.

Another aspect of the trust decision is the ability of the platform to resist attempts to change the controlling environment. The Intel® TXT platform will resist attempts by software processes to change the controlling environment or bypass the bounds set by the controlling environment.

Intel® TXT is a set of extensions designed to provide a measured and controlled launch of system software that will then establish a protected environment for itself and any additional software that it may execute.

These extensions enhance two areas:

- The launching of the Measured Launched Environment (MLE).
- The protection of the MLE from potential corruption.

The enhanced platform provides these launch and control interfaces using Safer Mode Extensions (SMX).

The SMX interface includes the following functions:

- Measured/Verified launch of the MLE.
- Mechanisms to ensure the above measurement is protected and stored in a secure location.
- Protection mechanisms that allow the MLE to control attempts to modify itself.

The processor also offers additional enhancements to System Management Mode (SMM) architecture for enhanced security and performance. The processor provides new MSRs to:

- Enable a second SMM range
- Enable SMM code execution range checking
- Select whether SMM Save State is to be written to legacy SMRAM or to MSRs
- Determine if a thread is going to be delayed entering SMM
- Determine if a thread is blocked from entering SMM
- Targeted SMI, enable/disable threads from responding to SMIs, both VLWs, and IPI

For the above features, BIOS should test the associated capability bit before attempting to access any of the above registers. The capability bits are discussed in the register description.

For more information, refer to the Intel® Trusted Execution Technology Measured Launched Environment Programming Guide at:

<http://www.intel.com/content/www/us/en/software-developers/intel-txt-software-development-guide.html>.

Note: Intel® TXT Technology may not be available on all SKUs.

Intel® Advanced Encryption Standard New Instructions

The processor supports Intel® Advanced Encryption Standard New Instructions (Intel® AES-NI) that are a set of Single Instruction Multiple Data (SIMD) instructions that enable fast and secure data encryption and decryption based on the Advanced Encryption Standard (AES). Intel® AES-NI is valuable for a wide range of cryptographic applications, such as applications that perform bulk encryption/decryption, authentication, random number generation, and authenticated encryption. AES is broadly accepted as the standard for both government and industrial applications and is widely deployed in various protocols.

Intel® AES-NI consists of six Intel® SSE instructions. Four instructions, AESENC, AESENCLAST, AESDEC, and AESDELAST facilitate high-performance AES encryption and decryption. The other two, AESIMC and AESKEYGENASSIST, support the AES key expansion procedure. Together, these instructions provide full hardware for supporting AES; offering security, high performance, and a great deal of flexibility.

This generation of the processor has increased the performance of the Intel® AES-NI significantly compared to previous products.

The Intel® AES-NI specifications and functional descriptions are included in the *Intel® 64 Architectures Software Developer's Manual, Volume 2* Available at:

<http://www.intel.com/products/processor/manuals>

Note: Intel® AES-NI Technology may not be available on all SKUs.

Perform Carry-Less Multiplication Quad Word Instruction

The processor supports the carry-less multiplication instruction, ie, Perform Carry-Less Multiplication Quad Word Instruction (PCLMULQDQ). PCLMULQDQ is a Single Instruction Multiple Data (SIMD) instruction that computes the 128-bit carry-less multiplication of two 64-bit operands without generating and propagating carries. Carry-less multiplication is an essential processing component of several cryptographic systems and standards. Hence, accelerating carry-less multiplication can significantly contribute to achieving high-speed secure computing and communication.

PCLMULQDQ specifications and functional descriptions are included in the *Intel® 64 Architectures Software Developer's Manual, Volume 2* Available at:

<http://www.intel.com/products/processor/manuals>

Intel® Secure Key

The processor supports Intel® Secure Key (formerly known as Digital Random Number Generator or DRNG), a software visible random number generation mechanism supported by a high-quality entropy source. This capability is available to programmers through the RDRAND instruction. The resultant random number generation capability is designed to comply with existing industry standards in this regard (ANSI X9.82 and NIST SP 800-90).

Some possible usages of the RDRAND instruction include cryptographic key generation as used in a variety of applications, including communication, digital signatures, secure storage, etc.

RDRAND specifications and functional descriptions are included in the *Intel® 64 Architectures Software Developer's Manual, Volume 2*. Available at:

<http://www.intel.com/products/processor/manuals>

Execute Disable Bit

The Execute Disable Bit allows memory to be marked as non-executable when combined with a supporting operating system. If code attempts to run in non-executable memory, the processor raises an error to the operating system. This feature can prevent some classes of viruses or worms that exploit buffer overrun vulnerabilities and can, thus, help improve the overall security of the system.

Boot Guard Technology

Boot Guard technology is a part of boot integrity protection technology. Boot Guard can help protect the platform boot integrity by preventing the execution of unauthorized boot blocks. With Boot Guard, platform manufacturers can create boot policies such that invocation of an unauthorized (or untrusted) boot block will trigger the platform protection per the manufacturer's defined policy.

With verification based in the hardware, Boot Guard extends the trust boundary of the platform boot process down to the hardware level.

Boot Guard accomplishes this by:

- Providing of hardware-based Static Root of Trust for Measurement (S-RTM) and the Root of Trust for Verification (RTV) using Intel architectural components.
- Providing of architectural definition for platform manufacturer Boot Policy.
- Enforcing manufacturer provided Boot Policy using Intel architectural components.

Benefits of this protection are that Boot Guard can help maintain platform integrity by preventing re-purposing of the manufacturer's hardware to run an unauthorized software stack.

Note: Boot Guard availability may vary between the different SKUs.

Intel® Supervisor Mode Execution Protection

Intel® Supervisor Mode Execution Protection (Intel® SMEP) is a mechanism that provides the next level of system protection by blocking malicious software attacks from user mode code when the system is running in the highest privilege level. This technology helps to protect from virus attacks and unwanted code from harming the system. For more information, refer to *Intel® 64 Architectures Software Developer's Manual, Volume 3a*:

<http://www.intel.com/products/processor/manuals>

Intel® Supervisor Mode Access Protection

Intel® Supervisor Mode Access Protection (Intel® SMAP) is a mechanism that provides next level of system protection by blocking a malicious user from tricking the operating system into branching off user data. This technology shuts down very popular attack vectors against operating systems.

For more information, refer to the *Intel® 64 Architectures Software Developer's Manual, Volume 3*:

<http://www.intel.com/products/processor/manuals>

Intel® Secure Hash Algorithm Extensions

The Intel® Secure Hash Algorithm Extensions (Intel® SHA Extensions) is one of the most commonly employed cryptographic algorithms. Primary usages of SHA include data integrity, message authentication, digital signatures, and data de-duplication. As the pervasive use of security solutions continues to grow, SHA can be seen in more applications now than ever. The Intel® SHA Extensions are designed to improve the performance of these compute-intensive algorithms on Intel® architecture-based processors.

The Intel® SHA Extensions are a family of seven instructions based on the Intel® Streaming SIMD Extensions (Intel® SSE) that are used together to accelerate the performance of processing SHA-1 and SHA-256 on Intel architecture-based processors. Given the growing importance of SHA in our everyday computing devices, the new instructions are designed to provide a needed boost of performance to hashing a single buffer of data. The performance benefits will not only help improve responsiveness and lower power consumption for a given application, but they may also enable developers to adopt SHA in new applications to protect data while delivering to their user experience goals. The instructions are defined in a way that simplifies their mapping into the algorithm processing flow of most software libraries, thus enabling easier development.

More information on Intel® SHA can be found at:

<http://software.intel.com/en-us/artTGLes/intel-sha-extensions>

User Mode Instruction Prevention

User Mode Instruction Prevention (UMIP) provides additional hardening capability to the OS kernel by allowing certain instructions to execute only in supervisor mode (Ring 0).

If the OS opt-in to use UMIP, the following instruction are enforced to run in supervisor mode:

- **SGDT** - Store the GDTR register value
- **SIDT** - Store the IDTR register value
- **SLDT** - Store the LDTR register value

- **SMSW** - Store Machine Status Word
- **STR** - Store the TR register value

An attempt at such execution in user mode causes a general protection exception (#GP).

UMIP specifications and functional descriptions are included in the *Intel® 64 Architectures Software Developer's Manual, Volume 3*. Available at:

<http://www.intel.com/products/processor/manuals>

Read Processor ID

A companion instruction that returns the current logical processor's ID and provides a faster alternative to using the RDTSCP instruction.

Read Processor ID (RDPID) specifications and functional descriptions are included in the *Intel® 64 Architectures Software Developer's Manual, Volume 2* Available at:

<http://www.intel.com/products/processor/manuals>

Intel® Total Memory Encryption - Multi-Key

This technology encrypts the platform's entire memory with multiple encryption keys. Intel® Total Memory Encryption (Intel® TME), when enabled via BIOS configuration, ensures that all memory accessed from the Intel processor is encrypted.

Intel TME encrypts memory accesses using the AES XTS algorithm with 128-bit keys. The global encryption key used for memory encryption is generated using a hardened random number generator in the processor and is not exposed to software.

Software (OS/VMM) manages the use of keys and can use each of the available keys for encrypting any page of the memory. Thus, Intel® Total Memory Encryption - Multi-key (Intel® TME-MK) allows page granular encryption of memory. By default Intel TME-MK uses the Intel TME encryption key unless explicitly specified by software.

Data in-memory and on the external memory buses is encrypted and exists in plain text only inside the processor. This allows existing software to operate without any modification while protecting memory using Intel TME. Intel TME does not protect memory from modifications.

Intel TME allows the BIOS to specify a physical address range to remain unencrypted. Software running on Intel TME enabled system has full visibility into all portions of memory that are configured to be unencrypted by reading a configuration register in the processor.

Notes:

- Memory access to nonvolatile memory (Intel® Optane™) is encrypted as well.
- More information on Intel TME-MK can be found at:
<https://software.intel.com/sites/default/files/managed/a5/16/Total-Memory-Encryption-Multi-Key-Spec.pdf>
- A cold boot is required when enable/ disable Intel TME feature on this platform.

Intel® Control-flow Enforcement Technology

Return-oriented Programming (ROP), and similarly CALL/JMP-oriented programming (COP/JOP), have been the prevalent attack methodology for stealth exploit writers targeting vulnerabilities in programs.

Intel® Control-flow Enforcement Technology (Intel® CET) provides the following components to defend against ROP/JOP style control-flow subversion attacks:

Shadow Stack

A shadow stack is a second stack for the program that is used exclusively for control transfer operations. This stack is separate from the data stack and can be enabled for operation individually in user mode or supervisor mode.

The shadow stack is protected from tamper through the page table protections such that regular store instructions cannot modify the contents of the shadow stack. To provide this protection the page table protections are extended to support an additional attribute for pages to mark them as “Shadow Stack” pages. When shadow stacks are enabled, control transfer instructions/flows such as near call, far call, call to interrupt/exception handlers, etc. store their return addresses to the shadow stack. The RET instruction pops the return address from both stacks and compares them. If the return addresses from the two stacks do not match, the processor signals a control protection exception (#CP). Stores from instructions such as MOV, XSAVE, etc. are not allowed to the shadow stack.

Indirect Branch Tracking

The ENDBR32 and ENDBR64 (collectively ENDBRANCH) are two new instructions that are used to mark valid indirect CALL/JMP target locations in the program. This instruction is a NOP on legacy processors for backward compatibility.

The processor implements a state machine that tracks indirect JMP and CALL instructions. When one of these instructions is seen, the state machine moves from IDLE to WAIT_FOR_ENDBRANCH state. In WAIT_FOR_ENDBRANCH state the next instruction in the program stream must be an ENDBRANCH. If an ENDBRANCH is not seen the processor causes a control protection fault (#CP), otherwise the state machine moves back to IDLE state.

More information on Intel® CET can be found at:

<https://software.intel.com/sites/default/files/managed/4d/2a/control-flow-enforcement-technology-preview.pdf>

KeyLocker Technology

A method to make long-term keys short-lived without exposing them. This protects against vulnerabilities when keys can be exploited and used to attack encrypted data such as disk drives.

An instruction (LOADIWKEY) allows the OS to load a random wrapping value (IWKey). The IWKey can be backed up and restored by the OS to/from the PCH in a secure manner.

The Software can wrap its own key via the ENCODEKEY instruction and receive a handle. The handle is used with the AES*KL instructions to handle encrypt and decrypt operations. Once a handle is obtained, the software can delete the original key from memory.

Devil's Gate Rock

Devil's Gate Rock (DGR) is a BIOS hardening technology that splits SMI (System Management Interrupts) handlers into Ring 3 and Ring 0 portions.

Supervisor/user paging on the smaller Ring 0 portion will enforce access policy for all the ring 3 code with regard to the SMM state save, MSR registers, IO ports and other registers.

The Ring 0 portion can perform save/restore of register context to allow the Ring 3 section to make use of those registers without having access to the OS context or the ability to modify the OS context.

The Ring 0 portion is signed and provided by Intel. This portion is attested by the processor.

Power and Performance Technologies

Intel® Smart Cache Technology

The Intel® Smart Cache Technology is a shared Last Level Cache (LLC).

- The LLC is non-inclusive.
- The LLC may also be referred to as a 3rd level cache.
- The LLC is shared between all IA cores as well as the Processor Graphics.
- For P Cores The 1st and 2nd level caches are not shared between physical cores and each physical core has a separate set of caches.
- For E Cores The 1st level cache is not shared between physical cores and each physical core has a separate set of caches.
- For E Cores The 2nd level cache is shared between 4 physical cores.
- The size of the LLC is SKU specific with a maximum of 3MB per P physical core or 4 E cores and is a 12-way associative cache.

IA Cores Level 1 and Level 2 Caches

P Cores 1st level cache is divided into a data cache (DFU) and an instruction cache (IFU). The processor 1st level cache size is 48KB for data and 32KB for instructions. The 1st level cache is an 12-way associative cache.

E Cores 1st level cache is divided into a data cache (DFU) and an instruction cache (IFU). The processor 1st level cache size is 32KB for data and 64KB for instructions. The 1st level cache is an 8-way associative cache.

The 2nd level cache holds both data and instructions. It is also referred to as mid-level cache or MLC. The P Cores 2nd level cache size is 1.25 MB and is a 10-way non-inclusive associative cache., 4 E Cores processors share 2MB 2nd level cache and is a 16-way non-inclusive associative cache.

Hybrid Cache

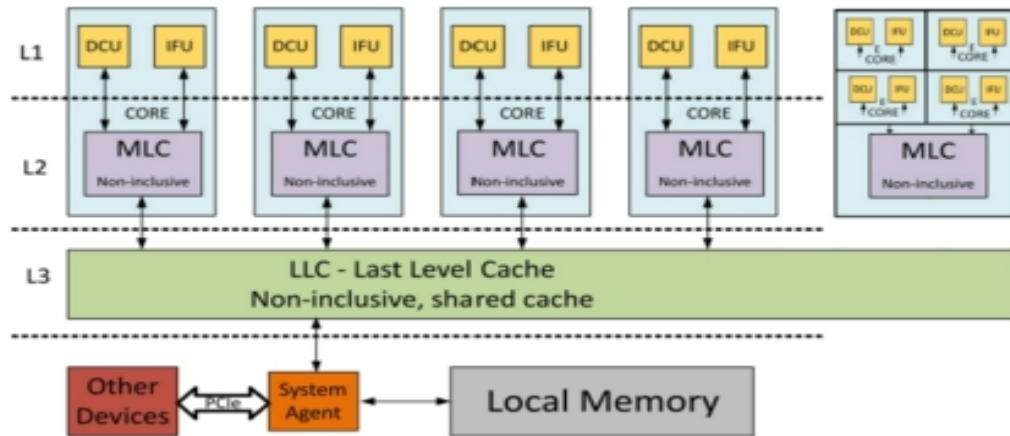

Notes:

1. L1 Data cache (DCU) - 48KB (P-core) - 32KB (E-Core)
2. L1 Instruction cache (IFU) - 32KB (P-Core) - 64KB (E-Core)
3. MLC - Mid Level Cache - 1.25MB (P-Core) - 2MB (shared by 4 E-Cores)

Ring Interconnect

The Ring is a high speed, wide interconnect that links the processor cores, processor graphics and the System Agent.

The Ring shares frequency and voltage with the Last Level Cache (LLC).

The Ring's frequency dynamically changes. Its frequency is relative to both processor cores and processor graphics frequencies.

Intel® Performance Hybrid Architecture

The processor contains two types of cores, denoted as P-Cores and E-Cores (P core is a Performance core and E core is efficient core).

The P-Cores and E-Cores share the same instruction set.

The available instruction sets, when hybrid computing is enabled, is limited compared to the instruction sets available to P-Cores.

P core and E core frequency's will be determined by the processor algorithmic, to maximize performance and power optimization.

For more details, refer to:

<https://www.intel.com/content/www/us/en/developer/articles/technical/hybrid-architecture.html>

Note: Hybrid Computing may not be available on all SKUs.

Intel® Turbo Boost Max Technology 3.0

The Intel® Turbo Boost Max Technology 3.0 (ITBMT 3.0) grants a different maximum Turbo frequency for individual processor cores.

To enable ITBMT 3.0 the processor exposes individual core capabilities; including diverse maximum turbo frequencies.

An operating system that allows for varied per core frequency capability can then maximize power savings and performance usage by assigning tasks to the faster cores, especially on low core count workloads.

Processors enabled with these capabilities can also allow software (most commonly a driver) to override the maximum per-core Turbo frequency limit and notify the operating system via an interrupt mechanism.

For more information on the Intel® Turbo Boost Max 3.0 Technology, refer to <http://www.intel.com/content/www/us/en/architecture-and-technology/turbo-boost/turbo-boost-max-technology.html>

Note: Intel® Turbo Boost Max 3.0 Technology may not be available on all SKUs.

Intel® Hyper-Threading Technology

The processor supports Intel® Hyper-Threading Technology (Intel® HT Technology) that allows an execution processor IA core to function as two logical processors. While some execution resources such as caches, execution units, and buses are shared, each logical processor has its own architectural state with its own set of general-purpose registers and control registers. This feature should be enabled using the BIOS and requires operating system support.

Intel recommends enabling Intel® Hyper-Threading Technology with Microsoft* Windows* 7 or newer and disabling Intel® Hyper-Threading Technology using the BIOS for all previous versions of Windows* operating systems.

Note: Intel® HT Technology may not be available on all SKUs.

Intel® Turbo Boost Technology 2.0

The Intel® Turbo Boost Technology 2.0 allows the processor IA core/processor graphics core to opportunistically and automatically run faster than the processor IA core base frequency/processor graphics base frequency if it is operating below power, temperature, and current limits. The Intel® Turbo Boost Technology 2.0 feature is designed to increase the performance of both multi-threaded and single-threaded workloads.

Compared with previous generation products, Intel® Turbo Boost Technology 2.0 will increase the ratio of application power towards Processor Base Power (a.k.a TDP) and also allows to increase power above Processor Base Power (a.k.a TDP) as high as PL2 for short periods of time.

Thus, thermal solutions and platform cooling that are designed to less than thermal design guidance might experience thermal and performance issues since more applications will tend to run at the maximum power limit for significant periods of time.

Note: Intel® Turbo Boost Technology 2.0 may not be available on all SKUs.

Intel® Turbo Boost Technology 2.0 Power Monitoring

When operating in turbo mode, the processor monitors its own power and adjusts the processor and graphics frequencies to maintain the average power within limits over a thermally significant time period. The processor estimates the package power for all components on the package. In the event that a workload causes the temperature to exceed program temperature limits, the processor will protect itself using the Adaptive Thermal Monitor.

Intel® Turbo Boost Technology 2.0 Power Control

Illustration of Intel® Turbo Boost Technology 2.0 power control is shown in the following sections and figures. Multiple controls operate simultaneously allowing customization for multiple systems thermal and power limitations. These controls allow for turbo optimizations within system constraints and are accessible using MSR, MMIO, and PECL interfaces.

Intel® Turbo Boost Technology 2.0 Frequency

To determine the highest performance frequency amongst active processor IA cores, the processor takes the following into consideration:

- The number of processor IA cores operating in the C0 state.
- The estimated processor IA core current consumption and ICCMax settings.
- The estimated package prior and present power consumption and turbo power limits.
- The package temperature.

Any of these factors can affect the maximum frequency for a given workload. If the power, current, or thermal limit is reached, the processor will automatically reduce the frequency to stay within its Processor Base Power (a.k.a TDP) limit. Turbo processor frequencies are only active if the operating system is requesting the P0 state. For more information on P-states and C-states, refer to [Power Management](#).

Enhanced Intel SpeedStep® Technology

Enhanced Intel SpeedStep® Technology enables OS to control and select P-state. The following are the key features of Enhanced Intel SpeedStep® Technology:

- Multiple frequencies and voltage points for optimal performance and power efficiency. These operating points are known as P-states.
- Frequency selection is software controlled by writing to processor MSRs. The voltage is optimized based on the selected frequency and the number of active processors IA cores.
 - Once the voltage is established, the PLL locks on to the target frequency.
 - All active processor IA cores share the same frequency and voltage. In a multi-core processor, the highest frequency P-state requested among all active IA cores is

selected.

- Software-requested transitions are accepted at any time. If a previous transition is in progress, the new transition is deferred until the previous transition is completed.
- The processor controls voltage ramp rates internally to ensure glitch-free transitions.

Note: Because there is low transition latency between P-states, a significant number of transitions per-second are possible.

Intel® Thermal Velocity Boost (Intel® TVB)

Intel® Thermal Velocity Boost allows the processor IA core to opportunistically and automatically increase the Intel® Turbo Boost Technology 2.0 frequency speed bins whenever processor temperature and voltage allows.

The Intel® Thermal Velocity Boost feature is designed to increase performance of both multi-threaded and singlethreaded workloads.

Note: Intel® Thermal Velocity Boost (Intel® TVB) may not be available on all SKUs.

Intel® Speed Shift Technology

Intel® Speed Shift Technology is an energy efficient method of frequency control by the hardware rather than relying on OS control. OS is aware of available hardware P-states and requests the desired P-state or it can let the hardware determine the P-state. The OS request is based on its workload requirements and awareness of processor capabilities. Processor decision is based on the different system constraints for example Workload demand, thermal limits while taking into consideration the minimum and maximum levels and activity window of performance requested by the Operating System.

Intel® Advanced Vector Extensions 2 (Intel® AVX2)

Intel® Advanced Vector Extensions 2.0 (Intel® AVX2) is the latest expansion of the Intel instruction set. Intel® AVX2 extends the Intel® Advanced Vector Extensions (Intel® AVX) with 256-bit integer instructions, floating-point fused multiply-add (FMA) instructions, and gather operations. The 256-bit integer vectors benefit math, codec, image, and digital signal processing software. FMA improves performance in face detection, professional imaging, and high-performance computing. Gather operations increase vectorization opportunities for many applications. In addition to the vector extensions, this generation of Intel processors adds new bit manipulation instructions useful in compression, encryption, and general purpose software. For more information on Intel® AVX, refer to <http://www.intel.com/software/avx>

Intel® Advanced Vector Extensions (Intel® AVX) are designed to achieve higher throughput to certain integer and floating point operation. Due to varying processor power characteristics, utilizing AVX instructions may cause a) parts to operate below the base frequency b) some parts with Intel® Turbo Boost Technology 2.0 to not achieve any or maximum turbo frequencies. Performance varies depending on hardware, software and system configuration and you should consult your system manufacturer for more information.

Intel® Advanced Vector Extensions refers to Intel® AVX or Intel® AVX2 .

For more information on Intel® AVX, refer to <https://software.intel.com/en-us/isa-extensions/intel-avx>.

Note: Intel® AVX and AVX2 Technologies may not be available on all SKUs.

Intel® AVX2 Vector Neural Network Instructions (AVX2 VNNI)

Vector instructions for deep learning extension for AVX2.

Note: Intel® AVX and AVX2 Technologies may not be available on all SKUs.

Intel® 64 Architecture x2APIC

The x2APIC architecture extends the xAPIC architecture that provides key mechanisms for interrupt delivery. This extension is primarily intended to increase processor addressability.

Specifically, x2APIC:

- Retains all key elements of compatibility to the xAPIC architecture:
 - Delivery modes
 - Interrupt and processor priorities
 - Interrupt sources
 - Interrupt destination types
- Provides extensions to scale processor addressability for both the logical and physical destination modes
- Adds new features to enhance the performance of interrupt delivery
- Reduces the complexity of logical destination mode interrupt delivery on link based architectures

The key enhancements provided by the x2APIC architecture over xAPIC are the following:

- Support for two modes of operation to provide backward compatibility and extensibility for future platform innovations:
 - In xAPIC compatibility mode, APIC registers are accessed through memory mapped interface to a 4K-Byte page, identical to the xAPIC architecture.
 - In the x2APIC mode, APIC registers are accessed through the Model Specific Register (MSR) interfaces. In this mode, the x2APIC architecture provides significantly increased processor addressability and some enhancements on interrupt delivery.
- Increased range of processor addressability in x2APIC mode:
 - Physical xAPIC ID field increases from 8 bits to 32 bits, allowing for interrupt processor addressability up to 4G-1 processors in physical destination mode. A processor implementation of x2APIC architecture can support fewer than 32-bits

in a software transparent fashion.

- Logical xAPIC ID field increases from 8 bits to 32 bits. The 32-bit logical x2APIC ID is partitioned into two sub-fields – a 16-bit cluster ID and a 16-bit logical ID within the cluster. Consequently, $(2^{20} - 16)$ processors can be addressed in logical destination mode. Processor implementations can support fewer than 16 bits in the cluster ID sub-field and logical ID sub-field in a software agnostic fashion.
- More efficient MSR interface to access APIC registers:
 - To enhance inter-processor and self-directed interrupt delivery as well as the ability to virtualize the local APIC, the APIC register set can be accessed only through MSR-based interfaces in x2APIC mode. The Memory Mapped IO (MMIO) interface used by xAPIC is not supported in x2APIC mode.
- The semantics for accessing APIC registers have been revised to simplify the programming of frequently-used APIC registers by system software. Specifically, the software semantics for using the Interrupt Command Register (ICR) and End Of Interrupt (EOI) registers have been modified to allow for more efficient delivery and dispatching of interrupts.
- The x2APIC extensions are made available to system software by enabling the local x2APIC unit in the “x2APIC” mode. To benefit from x2APIC capabilities, a new operating system and a new BIOS are both needed, with special support for the x2APIC mode.
- The x2APIC architecture provides backward compatibility to the xAPIC architecture and forwards extensible for future Intel platform innovations.

Note: Intel® x2APIC Technology may not be available on all SKUs.

For more information, refer to the Intel® *64 Architecture x2APIC Specification* at <http://www.intel.com/products/processor/manuals/>

Intel® Dynamic Tuning Technology

Intel® Dynamic Tuning (Intel® DTT) consists of a set of software drivers and applications that allow a system manufacturer to optimize system performance and usability by:

- Dynamically optimize turbo settings of IA processors, power and thermal states of the platform for optimal performance
- Dynamically adjust the processor's peak power based on the current power delivery capability for optimal system usability
- Dynamically mitigate radio frequency interference for better RF throughput.

Intel® GMM and Neural Network Accelerator

GNA stands for Gaussian Mixture Model and Neural Network Accelerator.

The GNA is used to process speech recognition without user training sequence. The GNA is designed to unload the processor cores and the system memory with complex speech recognition tasks and improve the speech recognition accuracy. The GNA is designed to compute millions of Gaussian probability density functions per second without loading the processor

cores while maintaining low power consumption.

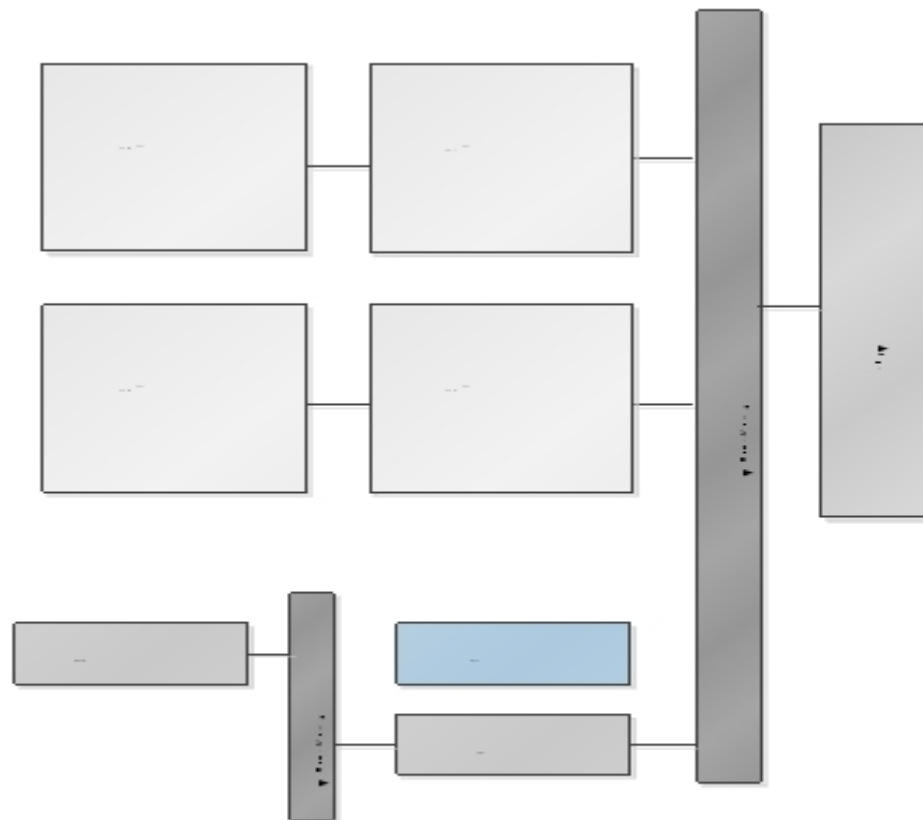

Cache Line Write Back

Writes back to memory the cache line (if dirty) that contains the linear address specified with the memory operand from any level of the cache hierarchy in the cache coherence domain. The line may be retained in the cache hierarchy in the non-modified state. Retaining the line in the cache hierarchy is a performance optimization (treated as a hint by hardware) to reduce the possibility of a cache miss on a subsequent access. Hardware may choose to retain the line at any of the levels in the cache hierarchy, and in some cases, may invalidate the line from the cache hierarchy. The source operand is a byte memory location.

The Cache Line Write Back (CLWB) instruction is documented in the Intel® Architecture Instruction Set Extensions Programming Reference (future architectures):

<https://software.intel.com/sites/default/files/managed/b4/3a/319433-024.pdf>

Remote Action Request

Remote Action Request (RAR) enables a significant speed up of several inter-processor operations by moving such operations from software (OS or application) to hardware.

The main feature is the speedup of TLB shutdowns.

A single RAR operation can invalidate multiple memory pages in the TLB.

A TLB (Translation Lookaside Buffer) is a per-core cache that holds mappings from virtual to physical addresses.

A TLB shutdown is the process of propagating a change in memory mapping (page table entry) to all the cores.

RAR supports the following operations:

- **Page Invalidation:** imitates the operation of performing INVLPG instructions corresponding or the TLB invalidation corresponding with “MOV CR3 / CRO”
- **Page Invalidation without CR3 Match:** identical to “Page invalidation”, except that the processor does not check for a CR3 match
- **PCID Invalidation:** imitates the operation of performing INVPCID instructions
- **EPT Invalidation:** imitates the operation of performing INVEPT instructions
- **VPID Invalidation:** imitates the operation of performing INVVPID instructions
- **MSR Write:** imitates the operation of WRMSR instructions on all cores

User Mode Wait Instructions

The *UMONITOR* and *UMWAIT* are user mode (Ring 3) instructions similar to the supervisor mode (Ring 0) *MONITOR/MWAIT* instructions without the C-state management capability.

TPAUSE is an enhanced *PAUSE* instruction.

The mnemonics for the three new instructions are:

- **UMONITOR:** operates just like *MONITOR* but allowed in all rings.
- **UMWAIT:** allowed in all rings, and no specification of target C-state.
- **TPAUSE:** similar to *PAUSE* but with a software-specified delay. Commonly used in spin loops.

Intel® Image Processing Unit

Platform Imaging Infrastructure

The platform imaging infrastructure is based on the following hardware components:

- **Camera Subsystem:** Located in the lid of the system and contains CMOS sensor, flash, LED, I/O interface (MIPI* CSI-2 and I2C*), focus control and other components.
- **Camera I/O Controller:** The I/O controller is located in the processor and contains a MIPI-CSI2 host controller. The host controller is a PCI device (independent of the IPU device). The CSI-2 HCI brings imaging data from an external image into the system and provides a command and control channel for the image using I²C.
- **Intel® IPU (Image Processing Unit):** The IPU processes raw images captured by Bayer sensors. The result images are used by still photography and video capture applications (JPEG, H.264, and so on.).

Processor Camera System

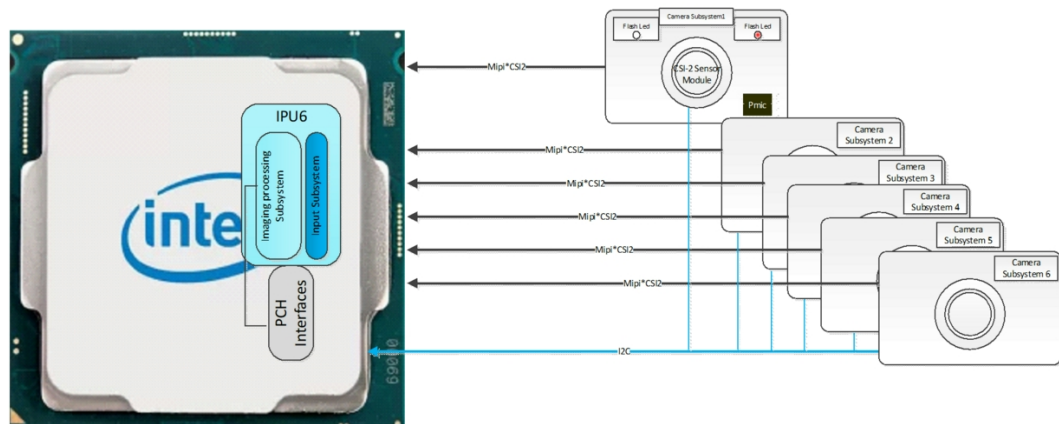

Intel® Image Processing Unit

IPU6 is Intel's 6th generation solution for an Imaging Processing Unit, providing advanced imaging functionality for Intel® Core™ branded processors, as well as more specialized functionality for High Performance Mobile Phones, Automotive, Digital Surveillance Systems (DSS), and other market segments.

IPU6 is a continuing evolution of the architecture introduced in IPU4 and enhanced in IPU5. Additional image quality improvements are introduced, as well as hardware accelerated support for temporal de-noising and new sensor technologies such as Spatially Variant Exposure HDR and Dual Photo Diode, among others.

IPU6 provides a complete high quality hardware accelerated pipeline, and is therefore not dependent on algorithms running on the vector processors to provide the highest quality output.

- H/P/U - Processor Lines has the most advance IPU6
- S/HX - Processor Lines has a lighter version of the IPU.

Debug Technologies

Intel® Processor Trace

Intel® Processor Trace (Intel® PT) is a tracing capability added to Intel® Architecture, for use in software debug and profiling. Intel® PT provides the capability for more precise software control flow and timing information, with limited impact on software execution. This provides an enhanced ability to debug software crashes, hangs, or other anomalies, as well as responsiveness and short-duration performance issues.

Intel® VTune™ Amplifier for Systems and the Intel® System Debugger are part of Intel® System Studio 2015 (and newer) product, which includes updates for the new debug and trace features, including Intel® PT and Intel® Trace Hub.

Intel® System Studio 2015 is available for download at <https://software.intel.com/en-us/system-studio>.

An update to the Linux* performance utility, with support for Intel® PT, is available for download at https://github.com/virtuoso/linux-perf/tree/intel_pt. It requires rebuilding the kernel and the perf utility.

Platform CrashLog

- The CrashLog feature is intended for use by system builders (OEMs) as a means to triage and perform first level debug of failures.
- CrashLog enables the BIOS or the OS to collect data on failures with the intent to collect and classify the data as well as analyze failure trends.
- CrashLog is a mechanism to collect debug information into a single location and then allow access to that data via multiple methods, including the BIOS and OS of the failing system.
- CrashLog is initiated by a Crash Data Detector on observation of error conditions (TCO watchdog timeout, machine check exceptions, etc.).
- Crash Data Detector notifies the Crash Data Requester of the error condition in order for the Crash Data Requester to collect Crash Data from several different IPs and/or Crash Nodes and stores the data to the Crash Data Storage (on-die SRAM) prior to the reset.
- After the system has rebooted, the Crash Data Collector reads the Crash Data from the Crash Data Storage and makes the data available to either to software and/or back to a central server to track error frequency and trends.

Telemetry Aggregator

The Telemetry Aggregator serves as an architectural and discoverable interface to hardware telemetry:

- Standardized PCIe discovery solution that enables software to discover and manage telemetry across products
- Standardized definitions for telemetry decode, including data type definitions
- Exposure of commonly used telemetry for power and performance debug including:
 - P-State status, residency and counters

- C-State status, residency and counters
- Energy monitoring
- Device state monitoring (for example, PCIe L1)
- Interconnect/bus bandwidth counters
- Thermal monitoring

Exposure of SoC state snapshot for atomic monitoring of package power states, uninterrupted by software that reads.

The Telemetry Aggregator is also a companion to the CrashLog feature where data is captured about the SoC at the point of a crash. These counters can provide insights into the nature of the crash.

Telemetry Aggregator

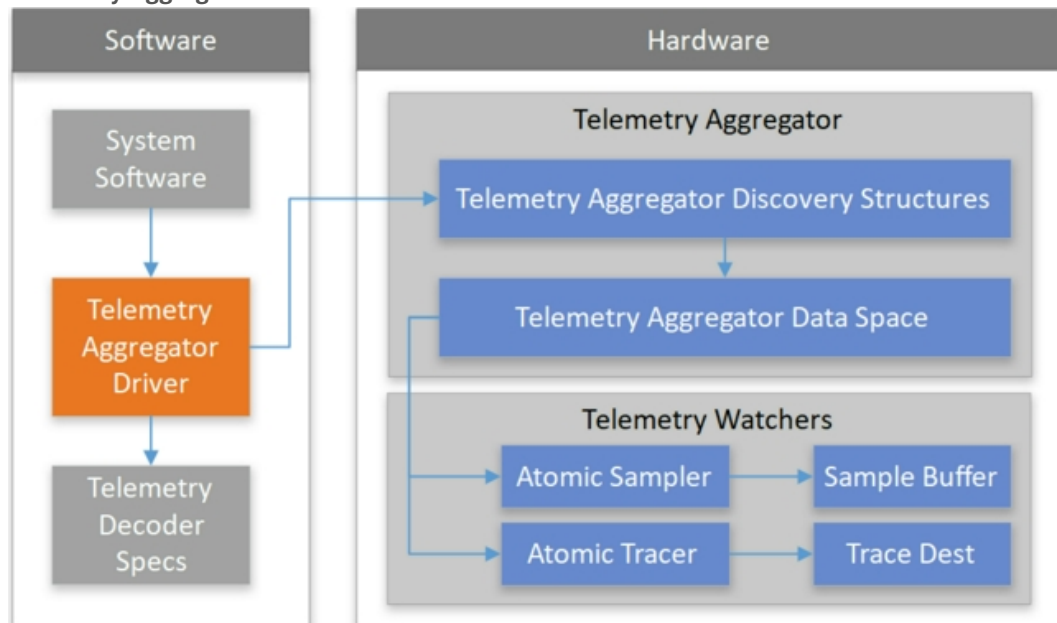

Clock Topology

The processor has 3 reference clocks that drive the various components within the SoC:

- Processor reference clock or base clock (BCLK). 100MHz with SSC.
- PCIe reference clock (PCTGLK). 100MHz with SSC.
- Fixed clock. 38.4MHz without SSC (crystal clock).

BCLK drives the following clock domains:

- Core
- Ring
- Graphics (GT)

- Memory Controller (MC)
- System Agent (SA)

PCTGLK drives the following clock domains:

- PCIe Controller(s)
- DMI/OPIO

Fixed clock drives the following clock domains:

- Display
- SVID controller
- Time Stamp Counters (TSC)
- Type C subsystem

Integrated Reference Clock PLL

The processor includes a phase lock loop (PLL) that generates the reference clock for the processor from a fixed crystal clock. The processor reference clock is also referred to as Base Clock or BCLK.

By integrating the BCLK PLL into the processor die, a cleaner clock is achieved at a lower power compared to the legacy PCH BCLK PLL solution.

The BCLK PLL has controls for RFI/EMI mitigations as well as Overclocking capabilities.

Intel Volume Management Device Technology

Objective

Standard Operating Systems generally recognize individual PCIe Devices and load individual drivers. This is undesirable in some cases such as, for example, when there are several PCIe-based hard-drives connected to a platform where the user wishes to configure them as part of a RAID array. The Operating System current treats individual hard-drives as separate volumes and not part of a single volume.

In other words, the Operating System requires multiple PCIe devices to have multiple driver instances, making volume management across multiple host bus adapters (HBAs) and driver instances difficult.

Intel Volume Management Device (VMD) technology provides a means to provide volume management across separate PCI Express HBAs and SSDs without requiring operating system support or communication between drivers. For example, the OS will see a single RAID volume instead of multiple storage volumes, when Volume Management Device is used.

Overview

Intel Volume Management Device technology does this by obscuring each storage controller from the OS, while allowing a single driver to be loaded that would control each storage controller.

Intel Volume Management technology requires support in BIOS and driver, memory and configuration space management.

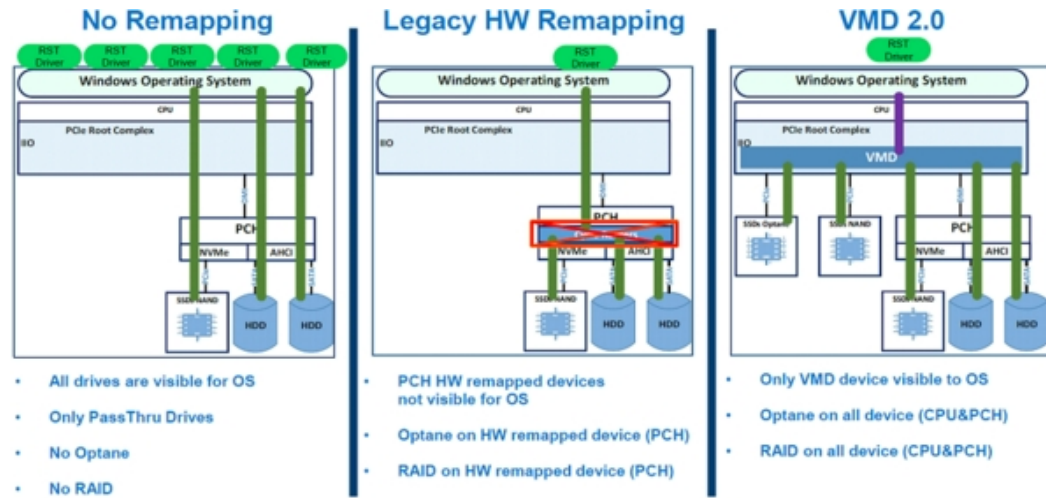

A Volume Management Device (VMD) exposes a single device to the operating system, which will load a single storage driver. The VMD resides in the processor's PCIe root complex and it appears to the OS as a root bus integrated endpoint. In the processor, the VMD is in a central location to manipulate access to storage devices which may be attached directly to the processor or indirectly through the PCH. Instead of allowing individual storage devices to be detected by the OS and therefore causing the OS to load a separate driver instance for each, VMD provides configuration settings to allow specific devices and root ports on the root bus to be invisible to the OS.

Access to these hidden target devices is provided by the VMD to the single, unified driver.

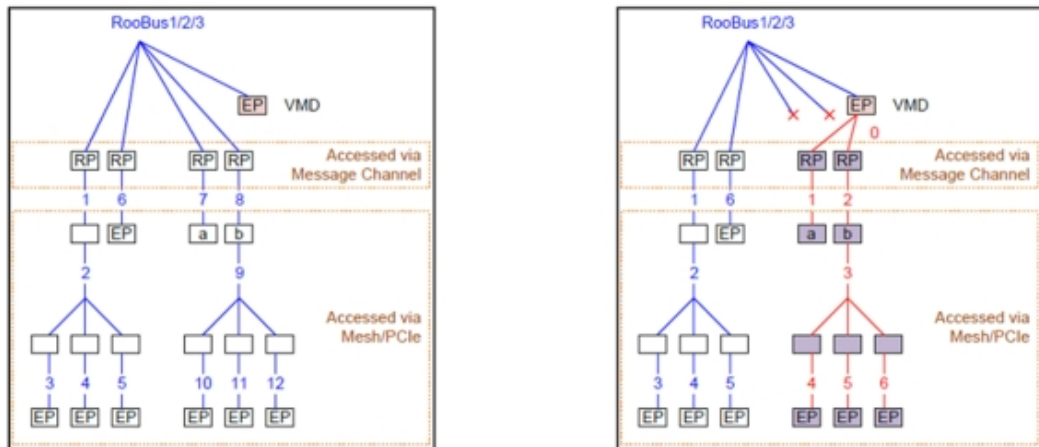

Features Supported

Supports MMIO mapped Configuration Space (CFGBAR):

- Supports MMIO Low

- Supports MMIO High
- Supports Register Lock or Restricted Access
- Supports Device Assign
- Function Assign
- MSI Remapping Disable

Deprecated Technologies

The processor has deprecated the following technologies and they are no longer supported:

- Intel® Memory Protection Extensions (Intel® MPX)
- Branch Monitoring Counters
- Hardware Lock Elision (HLE), part of Intel® TSX-NI
- Intel® Software Guard Extensions (Intel® SGX)
- Intel® TSX-NI
- Power Aware Interrupt Routing (PAIR)
- DDR Running Average Power Limit (DDR RAPL)

Processor Lines that support **Intel's Performance Hybrid Architecture** do not support the following:

- Intel® Advanced Vector Extensions 512 Bit

Power Management

Processor Power States

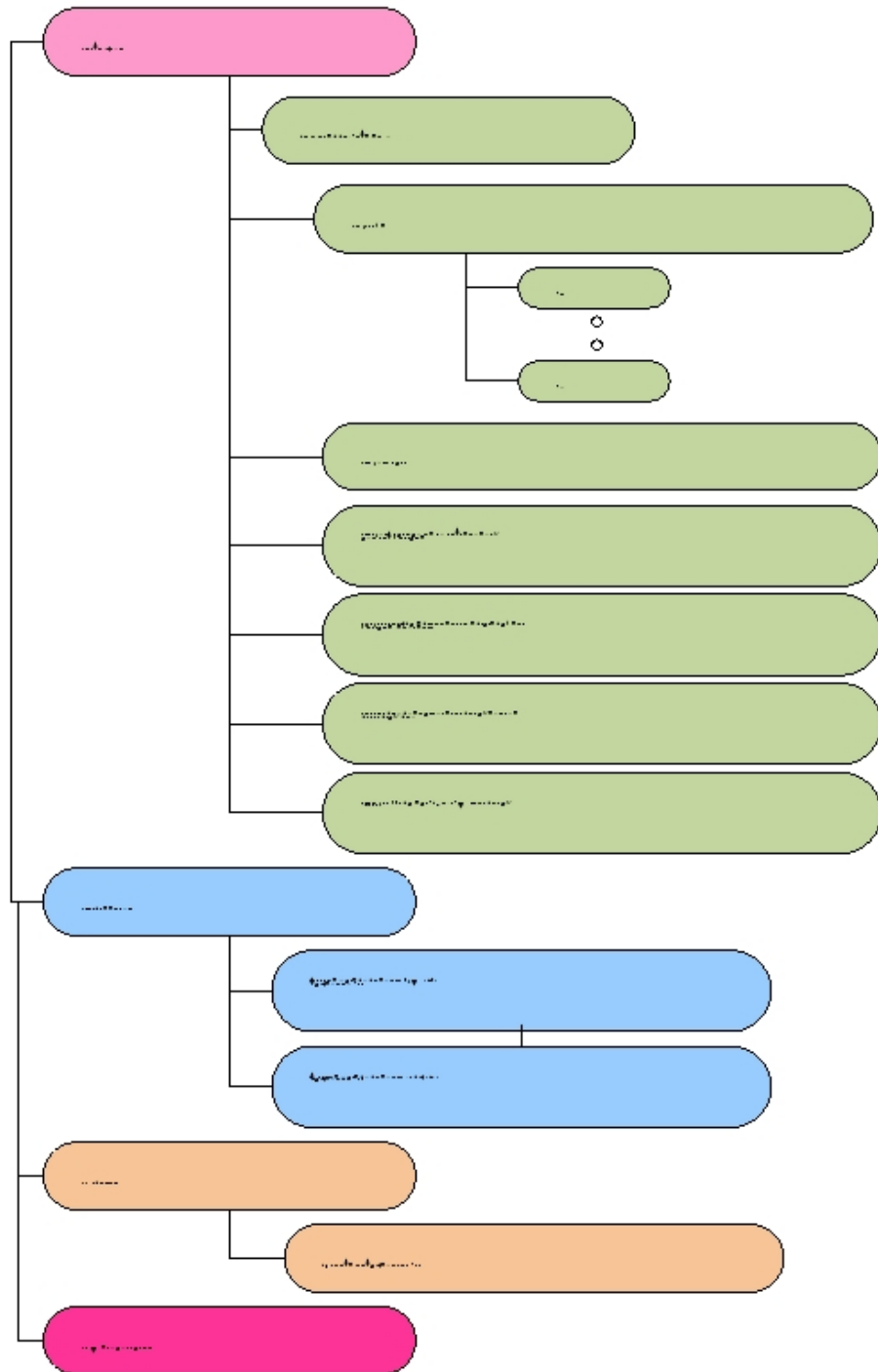

Processor Package and IA Core C-States

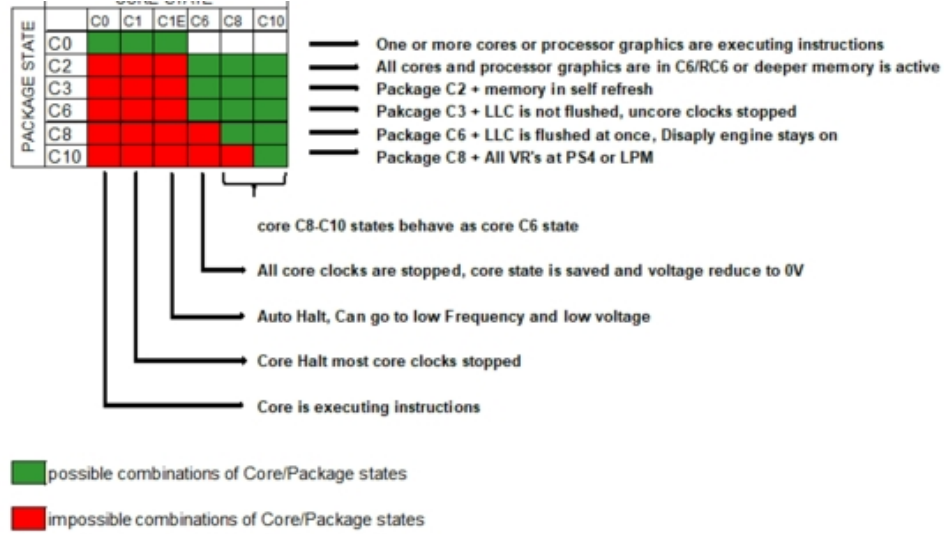

1. PkgC2/C3 are non-architectural: software cannot request to enter these states explicitly. These states are intermediate states between PkgC0 and PkgC6.
2. There are constraints that prevent the system to go deeper.
3. The “core state” relates to the core which is in the HIGEST power state in the package (most active).

Advanced Configuration and Power Interface (ACPI) States Supported

This section describes the ACPI states supported by the processor.

System States

State	Description
G0/S0/C0	Full On: CPU operating. Individual devices may be shut to save power. The different CPU operating levels are defined by Cx states.
G0/S0/Cx	Cx state: CPU manages C-states by itself and can be in low power state

State	Description
G1/S3	<p>Suspend-To-RAM (STR): The system context is maintained in system DRAM, but power is shut to non-critical circuits. Memory is retained, and refreshes continue. All external clocks are shut off; RTC clock and internal ring oscillator clocks are still toggling.</p> <p>In S3, SLP_S3 signal stays asserted, SLP_S4 and SLP_S5 are inactive until a wake occurs.</p>
G1/S4	<p>Suspend-To-Disk (STD): The context of the system is maintained on the disk. All power is then shut to the system except to the logic required to resume. Externally appears same as S5 but may have different wake events.</p> <p>In S4, SLP_S3 and SLP_S4 both stay asserted and SLP_S5 is inactive until a wake occurs.</p>
G2/S5	<p>Soft Off: System context not maintained. All power is shut except for the logic required to restart. A full boot is required when waking.</p> <p>Here, SLP_S3, SLP_S4, and SLP_S5 are all active until a wake occurs.</p>
G3	<p>Mechanical OFF: System context not maintained. All power shut except for the RTC. No "Wake" events are possible because the system does not have any power. This state occurs if the user removes the batteries, turns off a mechanical switch, or if the system power supply is at a level that is insufficient to power the "waking" logic. When system power returns the transition will depend on the state just prior to the entry to G3.</p>

Integrated Memory Controller (IMC) States

State	Description
Power-Up	CKE asserted. Active mode.
Pre-Charge Power Down	CKE de-asserted (not self-refresh) with all banks closed.
Active Power Down	CKE de-asserted (not self-refresh) with minimum one bank active.

State	Description
Self-Refresh	CKE de-asserted using device self-refresh.

G, S, and C Interface State Combinations

Global (G) State	Sleep (S) State	Processor Package (C) State	Processor State	System Clocks	Description
G0	S0	C0	Full On	On	Full On
G0	S0	C2 ¹	Deep Sleep	On	Deep Sleep
G0	S0	C3 ¹	Deep Sleep	On	Deep Sleep
G0	S0	C6	Deep Power Down	On	Deep Power Down
G0	S0	C8/C10	Off	On	Deeper Power Down
G1	S3	Power off	Off	Off, except RTC	Suspend to RAM
G1	S4	Power off	Off	Off, except RTC	Suspend to Disk
G2	S5	Power off	Off	Off, except RTC	Soft Off
G3	N/A	Power off	Off	Power off	Hard off

Notes:

1. PkgC2/C3 are non-architectural: software cannot request to enter these states explicitly. These states are intermediate states between PkgC0 and PkgC6.

Processor IA Core Power Management

While executing code, Enhanced Intel SpeedStep® Technology and Intel® Speed Shift technology optimizes the processor's IA core frequency and voltage based on workload. Each frequency and voltage operating point is defined by ACPI as a P-state. When the processor is not executing code, it is idle. A low-power idle state is defined by ACPI as a C-state. In general, deeper power C-states have longer entry and exit latencies.

OS/HW Controlled P-states

Enhanced Intel SpeedStep® Technology

Enhanced Intel SpeedStep® Technology enables OS to control and select P-state. For more information, refer to [Enhanced Intel SpeedStep® Technology](#).

Intel® Speed Shift Technology

Intel® Speed Shift Technology is an energy efficient method of frequency control by the hardware rather than relying on OS control. For more details, refer to [Intel® Speed Shift Technology](#).

Low-Power Idle States

When the processor is idle, low-power idle states (C-states) are used to save power. More power savings actions are taken for numerically higher C-states. However, deeper C-states have longer exit and entry latencies. Resolution of C-states occurs at the thread, processor IA core, and processor package level.

Caution: Long-term reliability cannot be assured unless all the Low-Power Idle States are enabled.

Idle Power Management Breakdown of the Processor IA Cores

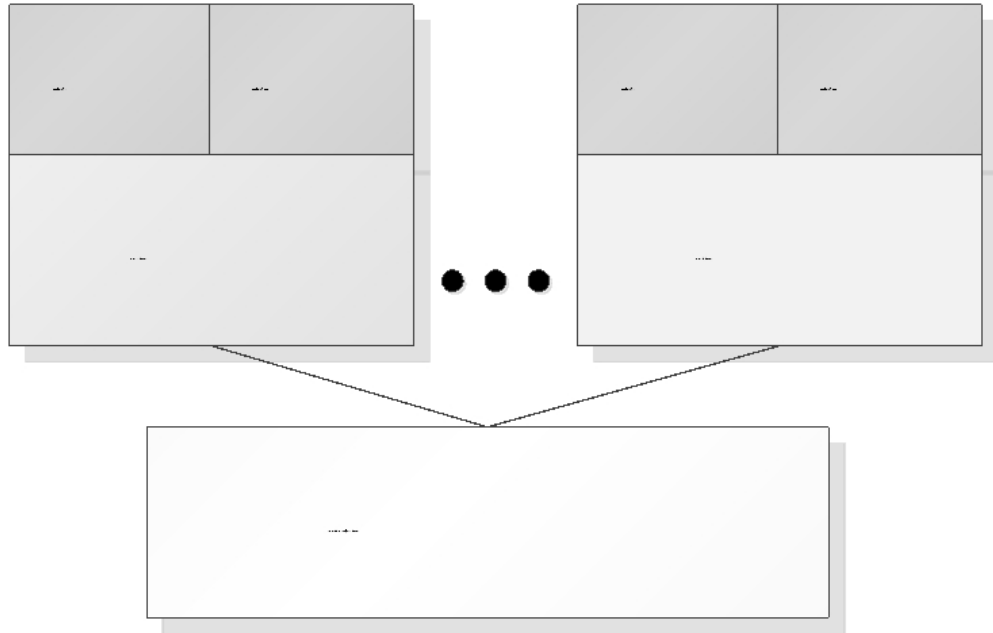

While individual threads can request low-power C-states, power saving actions only take place once the processor IA core C-state is resolved. processor IA core C-states are automatically resolved by the processor. For thread and processor IA core C-states, a transition to and from C0 state is required before entering any other C-state.

Requesting the Low-Power Idle States

The primary software interfaces for requesting low-power idle states are through the MWAIT instruction with sub-state hints and the HLT instruction (for C1 and C1E). However, the software may make C-state requests using the legacy method of I/O reads from the ACPI-defined processor clock control registers, referred to as P_LVLx. This method of requesting C-states provides legacy support for operating systems that initiate C-state transitions using I/O reads.

For legacy operating systems, P_LVLx I/O reads are converted within the processor to the equivalent MWAIT C-state request. Therefore, P_LVLx reads do not directly result in I/O reads to the system. The feature, known as I/O MWAIT redirection, should be enabled in the BIOS.

The BIOS can write to the C-state range field of the PMG_IO_CAPTURE MSR to restrict the range of I/O addresses that are trapped and emulate MWAIT like functionality. Any P_LVLx reads outside of this range do not cause an I/O redirection to MWAIT(Cx) like the request. They fall through like a normal I/O instruction.

When P_LVLx I/O instructions are used, MWAIT sub-states cannot be defined. The MWAIT sub-state is always zero if I/O MWAIT redirection is used. By default, P_LVLx I/O redirections enable the MWAIT 'break on EFLAGS.IF' feature that triggers a wake up on an interrupt, even if interrupts are masked by EFLAGS.IF.

Processor IA Core C-State Rules

The following are general rules for all processor IA core C-states unless specified otherwise:

- A processor IA core C-State is determined by the lowest numerical thread state (such as Thread 0 requests C1E while Thread 1 requests C6 state, resulting in a processor IA core C1E state). Refer to G, S, and C Interface State Combinations table.
- A processor IA core transitions to C0 state when:
 - An interrupt occurs
 - There is an access to the monitored address if the state was entered using an MWAIT/Timed MWAIT instruction
 - The deadline corresponding to the Timed MWAIT instruction expires
- An interrupt directed toward a single thread wakes up only that thread.
- If any thread in a processor IA core is active (in C0 state), the core's C-state will resolve to C0.
- Any interrupt coming into the processor package may wake any processor IA core.
- A system reset re-initializes all processor IA cores.

Core C-states

Core C-State	C-State Request Instruction	Description
C0	N/A	The normal operating state of a processor IA core where a code is being executed
C1	MWAIT(C1)	AutoHalt - core execution stopped, autonomous clock gating (package in C0 state)
C1E	MWAIT(C1E)	Core C1 + lowest frequency and voltage operating point (package in C0 state)
C6-C10	MWAIT(C6/C8/10) or IO read=P_LVL3//6/8	Processor IA, flush their L1 instruction cache, the L1 data cache, and L2 cache to the LLC shared cache cores save their architectural state to an SRAM before reducing IA cores voltage, if possible may also be reduced to 0V. Core clocks are off.

Core C-State Auto-Demotion

In general, deeper C-states, such as C6, have long latencies and have higher energy entry/exit costs. The resulting performance and energy penalties become significant when the entry/exit frequency of a deeper C-state is high. Therefore, incorrect or inefficient usage of deeper C-states have a negative impact on battery life and idle power. To increase residency and improve battery

life and idle power in deeper C-states, the processor supports C-state auto-demotion.

C-State auto-demotion:

- C6 to C1/C1E

The decision to demote a processor IA core from C6 to C1/C1E is based on each processor IA core's immediate residency history. Upon each processor IA core C6 request, the processor IA core C-state is demoted to C1 until a sufficient amount of residency has been established. At that point, a processor IA core is allowed to go into C6. If the interrupt rate experienced on a processor IA core is high and the processor IA core is rarely in a deep C-state between such interrupts, the processor IA core can be demoted to a C1 state.

This feature is disabled by default. BIOS should enable it in the PMG_CST_CONFIG_CONTROL register. The auto-demotion policy is also configured by this register.

Package C-States

The processor supports C0, C2, C3, C6, C8, and C10 package states. The following is a summary of the general rules for package C-state entry. These apply to all package C-states, unless specified otherwise:

- A package C-state request is determined by the lowest numerical processor IA core C-state amongst all processor IA cores.
- A package C-state is automatically resolved by the processor depending on the processor IA core idle power states and the status of the platform components.
 - Each processor IA core can be at a lower idle power state than the package if the platform does not grant the processor permission to enter a requested package C-state.
 - The platform may allow additional power savings to be realized in the processor.
 - For package C-states, the processor is not required to enter C0 before entering any other C-state.
 - Entry into a package C-state may be subject to auto-demotion – that is, the processor may keep the package in a deeper package C-state than requested by the operating system if the processor determines, using heuristics, that the deeper C-state results in better power/performance.

The processor exits a package C-state when a break event is detected. Depending on the type of break event, the processor does the following:

- If a processor IA core break event is received, the target processor IA core is activated and the break event message is forwarded to the target processor IA core.
 - If the break event is not masked, the target processor IA core enters the processor IA core C0 state and the processor enters package C0.
 - If the break event is masked, the processor attempts to re-enter its previous package state.
- If the break event was due to a memory access or snoop request,
 - But the platform did not request to keep the processor in a higher package C-state, the package returns to its previous C-state.

- And the platform requests a higher power C-state, the memory access or snoop request is serviced and the package remains in the higher power C-state.

Package C-State Entry and Exit

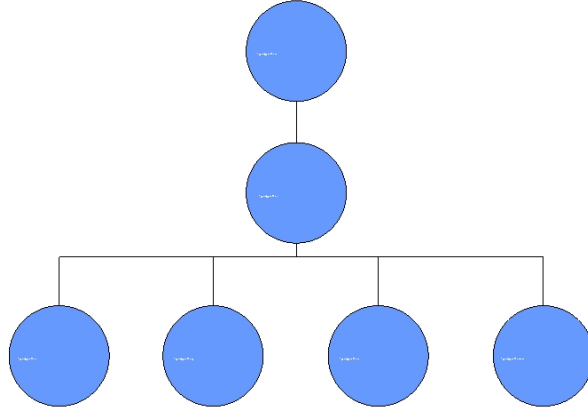

PKG C2 and C3 can not be requested explicitly by the software

Package C-States

Package C state	Description	Dependencies
PKG C0	Processor active state. At least one IA core in C0. Processor Graphic in RC0 (Graphics active state) or RC6 (Graphics Core power down state).	-

Package C state	Description	Dependencies
PKG C2	<p>Cannot be requested explicitly by the Software.</p> <p>All processor IA cores in C6 or deeper + Processor Graphic cores in RC6, memory path may be open.</p> <p>The processor will enter Package C2 when:</p> <ul style="list-style-type: none"> • Transitioning from Package C0 to deep Package C state or from deep Package C state to Package C0. • All IA cores requested C6 or deeper + Processor Graphic cores in RC6 but there are constraints (LTR, programmed timer events in the near future and so forth) prevent entry to any state deeper than C2 state. • All IA cores requested C6 or deeper + Processor Graphic cores in RC6 but a device memory access request is received. Upon completion of all outstanding memory requests, the processor transitions back into a deeper package C-state. 	<p>All processor IA cores in C6 or deeper.</p> <p>Processor Graphic cores in RC6.</p>
PKG C3	<p>Cannot be requested explicitly by the Software.</p> <p>All cores in C6 or deeper + Processor Graphics in RC6, LLC may be flushed and turned off, memory in self refresh, memory clock stopped.</p> <p>The processor will enter Package C3 when:</p> <ul style="list-style-type: none"> • All IA cores in C6 or deeper + Processor Graphic cores in RC6. • The platform components/devices allows proper LTR for entering Package C3. 	<p>All processor IA cores in C6 or deeper.</p> <p>Processor Graphics in RC6.</p> <p>memory in self refresh, memory clock stopped.</p> <p>LLC may be flushed and turned off.</p>
PKG C6	<p>Package C3 + BCLK is off + IMVP9.1 VRs voltage reduction/PSx state is possible.</p> <p>The processor will enter Package C6 when:</p> <ul style="list-style-type: none"> • All IA cores in C6 or deeper + Processor Graphic cores in RC6. • The platform components/devices allow proper LTR for entering Package C6. 	<p>Package C3.</p> <p>BCLK is off.</p> <p>IMVP9.1 VRs voltage reduction/PSx state is possible.</p>

Package C state	Description	Dependencies
PKG C8	<p>Of all IA cores requested C8 + LLC should be flushed at once, voltage will be removed from the LLC.</p> <p>The processor will enter Package C8 when:</p> <ul style="list-style-type: none"> • All IA cores in C8 or deeper + Processor Graphic cores in RC6. • The platform components/devices allow proper LTR for entering Package C8. 	<p>Package C6</p> <p>If all IA cores requested C8, LLC is flushed in a single step, voltage will be removed from the LLC.</p>
PKG C10	<p>Package C8 + display in PSR or powered, all VRs at PS4 + crystal clock off.</p> <p>The processor will enter Package C10 when:</p> <ul style="list-style-type: none"> • All IA cores in C10 + Processor Graphic cores in RC6. • The platform components/devices allow proper LTR for entering Package C10. 	<p>Package C8.</p> <p>All IA cores in C8 or deeper.</p> <p>Display in PSR or powered off¹.</p> <p>All VRs at PS4.</p> <p>Crystal clock off.</p>
<p>Note: Display In PSR is only on single embedded panel configuration and panel support PSR feature.</p>		

Package C-State Auto-Demotion

The Processor may demote the Package C-State to a shallower Package C-State to enable better performance, for example instead of going into Package C10, processor will demote to Package C6 (and shallower as required).

The processor's decision to demote the Package C-State is based on Power management parameters such as required C states latencies, entry/exit energy/power, Core wake rates, and device LTR (Latency Tolerance Report). This means that the processor is optimized to minimize platform energy for scenarios with low idle time.

Processor deeper Package C-State entry frequency is controlled to minimize platform energy. When Package C-State Auto-Demotion enabled, a reduced residency in a deeper Package C-State is expected during system runs with high wake rates.

No change at IDLE scenario power consumption due to this feature. Package C-State Auto-Demotion is enabled by default and controlled through BIOS menu.

Modern Standby

Modern Standby is a platform state. On display time out the OS requests the processor to enter package C10 and platform devices at RTD3 (or disabled) in order to attain low power in idle. Modern Standby requires proper BIOS and OS configuration.

Dynamic LLC Sizing

When all processor IA cores request C8 or deeper C-state, internal heuristics dynamically flushes the LLC. Once the processor IA cores enter a deep C-state, depending on their MWAIT sub-state request, the LLC is either gradually flushed N-ways at a time or flushed all at once. Upon the processor IA cores exiting to C0 state, the LLC is gradually expanded based on internal heuristics.

Package C-States and Display Resolutions

The integrated graphics engine has the frame buffer located in system memory. When the display is updated, the graphics engine fetches display data from system memory. Different screen resolutions and refresh rates have different memory latency requirements. These requirements may limit the deepest Package C-state the processor can enter. Other elements that may affect the deepest Package C-state available are the following:

- Display is on or off
- Single or multiple displays
- Native or non-native resolution
- Panel Self Refresh (PSR) technology

Note: Display resolution is not the only factor influencing the deepest Package C-state the processor can get into. Device latencies, interrupt response latencies, and core C-states are among other factors that influence the final package C-state the processor can enter.

Processor AUX Power Management

VCCIN AUX IMON Feature

This feature is the new power feature which allows the processor to read VCCIN Aux average current via the IMVP9.1 controller over SVID.

It allows the processor to get an accurate power estimation of VCCIN Aux, which is reflected in more accurate package power reporting and better accuracy in meeting the package power limits (PL1, PL2, and PL3).

VCCIN Aux IMON CPU strap will be enabled by default for best performance and power.

Processor Graphics Power Management

Memory Power Savings Technologies

Intel® Rapid Memory Power Management (Intel® RMPM)

Intel® Rapid Memory Power Management (Intel® RMPM) conditionally places memory into self-refresh when the processor is in package C3 or deeper power state to allow the system to remain in the deeper power states longer for memory not reserved for graphics memory. Intel® RMPM functionality depends on graphics/display state (relevant only when processor graphics is being used), as well as memory traffic patterns generated by other connected I/O devices.

Display Power Savings Technologies

Intel® Seamless Display Refresh Rate Switching Technology (Intel® SDRRS Technology) with eDP* Port

Intel® DRRS provides a mechanism where the monitor is placed in a slower refresh rate (the rate at which the display is updated). The system is smart enough to know that the user is not displaying either 3D or media like a movie where specific refresh rates are required. The technology is very useful in an environment such as a plane where the user is in battery mode doing E-mail, or other standard office applications. It is also useful where the user may be viewing web pages or social media sites while in battery mode.

Intel® OLED Power Saving Technology (Intel® OPST) 1.1

Intel® OPST solution uses same HW infrastructure as Intel® DPST. Frames are processed using frame change threshold based interrupt mechanism similar to Intel® DPST. Intel® OPST SW algorithm determines which pixels in the frame should be dimmed to save power keeping visual quality (such as contrast, color) impact to acceptable level. Since there is no backlight for OLED panels, the power savings come solely from pixel dimming.

Intel® Display Power Saving Technology (Intel® DPST)

The Intel® DPST technique achieves back-light power savings while maintaining a good visual experience. This is accomplished by adaptively enhancing the displayed image while decreasing the back-light brightness simultaneously. The goal of this technique is to provide equivalent end-user-perceived image quality at a decreased back-light power level.

1. The original (input) image produced by the operating system or application is analyzed by the Intel® DPST subsystem. An interrupt to Intel® DPST software is generated whenever a meaningful change in the image attributes is detected. (A meaningful change is when the Intel® DPST determines if the brightness of the displaying images and the image enhancement and back-light control needs to be altered.)
2. Intel® DPST subsystem applies an image-specific enhancement to increase image brightness.
3. A corresponding decrease to the back-light brightness is applied simultaneously to produce an image with similar user-perceived quality (such as brightness) as the original image.

Intel® DPST 7.1 has improved power savings without adversely affecting the performance.

Panel Self-Refresh 2 (PSR 2) Panel Self-Refresh feature allows the Processor Graphics core to enter low-power state when the frame buffer content is not changing constantly. This feature is available on panels capable of supporting Panel Self-Refresh. Apart from being able to support, the eDP* panel should be eDP 1.4 compliant. PSR 2 adds partial frame updates and requires an eDP 1.4 compliant panel.

Low-Power Single Pipe (LPSP)

Low-power single pipe is a power conservation feature that helps save power by keeping the inactive pipes powered OFF. LPSP is achieved by keeping a pipe enabled during eDP* only with minimal display pipeline support.

Low-Power Dual Pipe (LPDP)

This feature is similar to LPSP and is applicable for designs with dual eDP* panels.

Intel® Smart 2D Display Technology (Intel® S2DDT)

Intel® S2DDT reduces display refresh memory traffic by reducing memory reads required for display refresh. Power consumption is reduced by less accesses to the IMC. Intel S2DDT is only enabled in single pipe mode.

Intel® S2DDT is most effective with:

- Display images well suited to compression, such as text windows, slide shows, and so on. Poor examples are 3D games.
- Static screens such as screens with significant portions of the background showing 2D applications, processor benchmarks, and so on, or conditions when the processor is idle. Poor examples are full-screen 3D games and benchmarks that flip the display image at or near display refresh rates.

Processor Graphics Core Power Savings Technologies

Intel® Graphics Dynamic Frequency

Intel® Turbo Boost Technology 2.0 is the ability of the processor IA cores and graphics (Graphics Dynamic Frequency) cores to opportunistically increase frequency and/or voltage above the guaranteed processor and graphics frequency for the given part. Intel® Graphics Dynamic Frequency is a performance feature that makes use of unused package power and thermal to increase application performance. The increase in frequency is determined by how much power and thermal budget is available in the package, and the application demand for additional processor or graphics performance. The processor IA core control is maintained by an embedded controller. The graphics driver dynamically adjusts between P-States to maintain optimal performance, power, and thermal. The graphics driver will always place the graphics engine in its lowest possible P-State. Intel® Graphics Dynamic Frequency requires BIOS support. Additional power and thermal budget should be available.

Intel® Graphics Render Standby Technology (Intel® GRST)

Intel® Graphics Render Standby Technology is a technique designed to optimize the average power of the graphics part. The Graphics Render engine will be put in a sleep state, or Render Standby (RS), during times of inactivity or basic video modes. While in Render Standby state, the graphics part will place the VR (Voltage Regulator) into a low voltage state. Hardware will save the render context to the allocated context buffer when entering RS state and restore the render context upon exiting RS state.

Intel Capped Frames Per Second (CFPS)

Intel Capped Frames Per Second is a feature developed to save power during High FPS Gaming workloads while also achieving a tear and stutter free visual experience.

This feature ensures that the frame rate of the game does not exceed the panel refresh rate by matching screen updates to the Vertical Sync. That results fewer wakeups of graphics core and saves power.

When enabled, this feature works on any display panel, AC or DC mode and on any gaming workload.

System Agent Enhanced Intel SpeedStep® Technology

System Agent Enhanced Intel SpeedStep® Technology is a dynamic voltage frequency scaling of the System Agent clock based on memory utilization. Unlike processor core and package Enhanced Intel SpeedStep® Technology, System Agent Enhanced Intel SpeedStep® Technology has three valid operating points. When running light workload and SA Enhanced Intel SpeedStep® Technology is enabled, the DDR data rate may change as follows:

BIOS/MRC DDR training at maximum, mid and minimum frequencies sets I/O and timing parameters.

In order to achieve the optimal levels of performance and power, the memory initialization and training process performed during first system boot or after CMOS clear or after a BIOS update will take a longer time than a typical boot. During this initialization and training process, end users may see a blank screen. More information on the memory initialization process can be found in the industry standard JEDEC Specifications found on www.JEDEC.org.

Before changing the DDR data rate, the processor sets DDR to self-refresh and changes the needed parameters. The DDR voltage remains stable and unchanged.

Rest Of Platform (ROP) PMIC

In addition to discrete voltage regulators, Intel supports specific PMIC (Power Management Integrated Circuit) models to power the ROP rails. PMICs are typically classified as “Premium” or “Volume” ROP PMICs.

PCI Express* Power Management

- Active power management support using L0s (see below), L1 Substates(L1.1,L1.2)
- L0s is supported on PEG10/11 interface in S/HX Processor Lines.

- L0s is supported on PEG10 interface in H Processor Lines.
- L0s is supported on PEG60 interface in H/P/U Processor Lines
- L0s is supported on PEG60/62 interface in H/P/U15 Processor Lines
- L0s is not supported on PEG60 interface in S/HX Processor Lines.
- All inputs and outputs disabled in L2/L3 Ready state.
- S Processor PCIe* interface does not support Hot-Plug.

Note: An increase in power consumption may be observed when PCI Express* ASPM capabilities are disabled.

Package C-States with PCIe* Link States Dependencies

Processor Interface	L-State	Description	Package C-State
PCIe*	L1.0 or deeper	<p>L1- Higher latency, lower power “standby” state</p> <p>L2 – Auxiliary-powered Link, deep-energy-saving state.</p> <p>Disabled - The intent of the Disabled state is to allow a configured Link to be disabled until directed or Electrical Idle is exited (that is, due to a hot removal and insertion) after entering Disabled.</p> <p>No Device Attached - no physical device is attached on PEG port</p>	PC6-PC8
PCIe*	L1.2 or deeper	<p>L1- Higher latency, lower power “standby” state</p> <p>L2 – Auxiliary-powered Link, deep-energy-saving state.</p> <p>Disabled - The intent of the Disabled state is to allow a configured Link to be disabled until directed or Electrical Idle is exited (that is, due to a hot removal and insertion) after entering Disabled.</p> <p>No Device Attached - no physical device is attached on PEG port</p>	PC10

TCSS Power State

TCSS Power State

TCSS Power State	Allowed Package C Status	Device Attached	Description
TC0	PC0-PC3	Yes	xHCI, xDCI, USB4 controllers may be active. USB4 DMA / PCIe may be active.
TC7	PC6-PC10	Yes	xHCI and xDCI are in D3. USB4 controller is in D3 or D0 idle. USB4 PCIe is inactive.
TC-Cold	PC3-PC10	No	xHCI / xDCI / TBT DMA / TBT PCIe are in D3 IOM is active
TC10	PC6-PC10	No	Deepest Power state xHCI and xDCI are in D3. USB4 is in D3 or D0 idle. USB4 Cle is in inactive IOM is inactive
<p>IOM - TCSS Input Output Manager:</p> <ul style="list-style-type: none"> The IOM interacts with the SoC to perform power management, boot, reset, connect and disconnect devices to TYPE-C sub-system <p>TCSS Devices (xHCI / xDCI / TBT Controllers) - power states:</p> <ul style="list-style-type: none"> D0 - Device at Active state. D3 - Device at lowest-powered state. 			

Thermal Management

Processor Thermal Management

The thermal solution provides both component-level and system-level thermal management. To allow optimal operation and long-term reliability of Intel processor-based systems, the system/processor thermal solution should be designed so that the processor:

- Remains below the maximum junction temperature (T_{jMAX}) specification at the maximum Processor Base power (a.k.a TDP).
- Conforms to system constraints, such as system acoustics, system skin-temperatures, and exhaust-temperature requirements.

Caution: Thermal specifications given in this chapter are on the component and package level and apply specifically to the processor. Operating the processor outside the specified limits may result in permanent damage to the processor and potentially other components in the system.

Thermal Considerations

The Processor Base Power (a.k.a TDP) is the assured sustained power that should be used for the design of the processor thermal solution. Design to a higher thermal capability will get more Turbo residency. Processor Base Power is the time-averaged power dissipation that the processor is validated to not exceed during manufacturing while executing an Intel-specified high complexity workload at Base Frequency and at the maximum junction temperature as specified in the Datasheet for the SKU segment and configuration.

Note: The System on Chip processor integrates multiple compute cores and I/O on a single package. Platform support for specific usage experiences may require additional concurrency power to be considered when designing the power delivery and thermal sustained system capability.

The processor integrates multiple processing IA cores, graphics cores and for some SKUs a PCH on a single package. This may result in power distribution differences across the package and should be considered when designing the thermal solution.

Intel® Turbo Boost Technology 2.0 allows processor IA cores to run faster than the base frequency. It is invoked opportunistically and automatically as long as the processor is conforming to its temperature, power, power delivery, and current control limits. When Intel® Turbo Boost Technology 2.0 is enabled:

- The processor may exceed the Processor Base Power (a.k.a TDP) for short durations to utilize any available thermal capacitance within the thermal solution. The duration and time of such operation can be limited by platform runtime configurable registers within the processor.
- Graphics peak frequency operation is based on the assumption of only one of the graphics domains (GT/GTx) being active. This definition is similar to the IA core Turbo concept, where peak turbo frequency can be achieved when only one IA core is active. Depending on the workload being applied and the distribution across the graphics domains the user may not observe peak graphics frequency for a given workload or benchmark.
- Thermal solutions and platform cooling that is designed to less than thermal design guidance may experience thermal and performance issues.

Note: Intel® Turbo Boost Technology 2.0 availability may vary between the different SKUs.

Package Power Control

The package power control settings of PL1, PL2, PL3, PL4, and Tau allow the designer to configure Intel® Turbo Boost Technology 2.0 to match the platform power delivery and package thermal solution limitations.

- **Power Limit 1 (PL1):** A threshold for average power that will not exceed - recommend to set to equal Processor Base Power (a.k.a TDP). PL1 should not be set higher than thermal solution cooling limits.
- **Power Limit 2 (PL2):** A threshold that if exceeded, the PL2 rapid power limiting algorithms will attempt to limit the spike above PL2.
- **Power Limit 3 (PL3):** A threshold that if exceeded, the PL3 rapid power limiting algorithms will attempt to limit the duty cycle of spikes above PL3 by reactively limiting frequency. This is an optional setting
- **Power Limit 4 (PL4):** A limit that will not be exceeded, the PL4 power limiting algorithms will preemptively limit frequency to prevent spikes above PL4.
- **Turbo Time Parameter (Tau):** An averaging constant used for PL1 exponential weighted moving average (EWMA) power calculation.

Notes:

1. Implementation of Intel® Turbo Boost Technology 2.0 only requires configuring PL1, PL1, Tau and PL2.
2. PL3 is disabled by default.
3. The Intel Dynamic Tuning (DTT) is recommended for performance improvement in mobile platforms. Dynamic Tuning is configured by system manufacturers dynamically optimizing the processor power based on the current platform thermal and power delivery conditions. Contact Intel Representatives for enabling details.

Package Power Control

SOC/Platform Power Limiting Knobs Options Visual

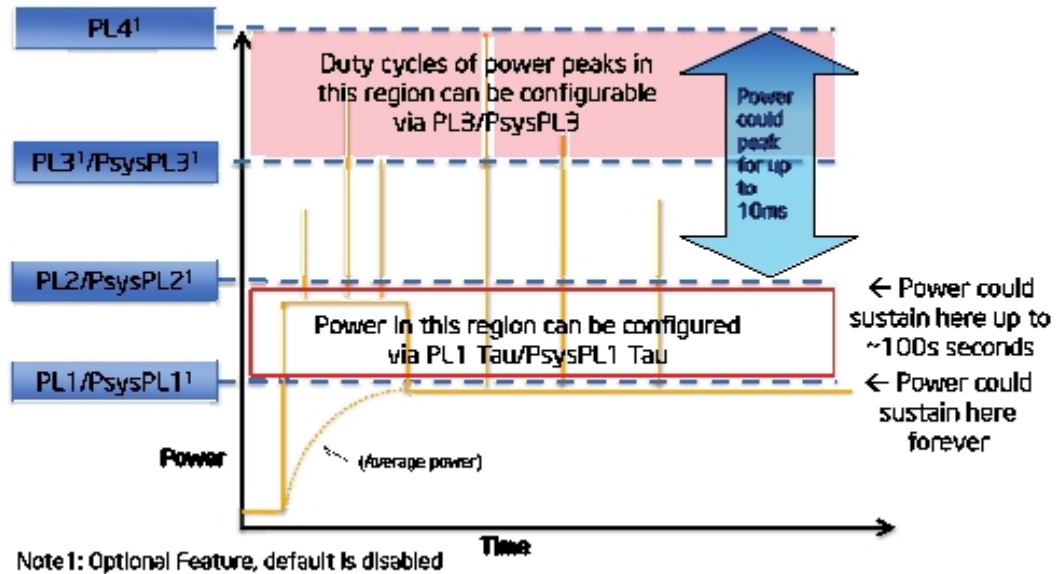

Platform Power Control

The processor introduces Psys (Platform Power) to enhance processor power management. The Psys signal needs to be sourced from a compatible charger circuit and routed to the IMVP9 (voltage regulator). This signal will provide the total thermally relevant platform power consumption (processor and rest of platform) via SVID to the processor.

When the Psys signal is properly implemented, the system designer can utilize the package power control settings of PsysPL1, PsysPL1 Tau, PsysPL2, and PsysPL3 for additional manageability to match the platform power delivery and platform thermal solution limitations for Intel® Turbo Boost Technology 2.0. The operation of the PsysPL1, PsysPL1 Tau, PsysPL2 and PsysPL3 are analogous to the processor power limits described in [Package Power Control](#).

- **Platform Power Limit 1 (PsysPL1):** A threshold for average platform power that will not be exceeded - recommend to set to equal platform thermal capability.
- **Platform Power Limit 2 (PsysPL2):** A threshold that if exceeded, the PsysPL2 rapid power limiting algorithms will attempt to limit the spikes above PsysPL2.
- **Platform Power Limit 3 (PsysPL3):** A threshold that if exceeded, the PsysPL3 rapid power limiting algorithms will attempt to limit the duty cycle of spikes above PsysPL3 by reactively limiting frequency.
- **PsysPL1 Tau:** An averaging constant used for PsysPL1 exponential weighted moving average (EWMA) power calculation.
- The Psys signal and associated power limits / Tau are optional for the system designer and disabled by default.

- The Psys data will not include power consumption for charging.
- The Intel Dynamic Tuning (DTT) is recommended for performance improvement in mobile platforms. Dynamic Tuning is configured by system manufacturers dynamically optimizing the processor power based on the current platform thermal and power delivery conditions. Contact Intel Representatives for enabling details.

Turbo Time Parameter (Tau)

Turbo Time Parameter (Tau) is a mathematical parameter (units of seconds) that controls the Intel® Turbo Boost Technology 2.0 algorithm. During a maximum power turbo event, the processor could sustain PL2 for a duration longer than the Turbo Time Parameter. If the power value and/or Turbo Time Parameter is changed during runtime, it may take some time based on the new Turbo Time Parameter level for the algorithm to settle at the new control limits. The time varies depending on the magnitude of the change, power limits and other factors. There is an individual Turbo Time Parameter associated with Package Power Control and Platform Power Control.

Assured Power (cTDP)

Assured Power (cTDP) form a design option where the processor's behavior and package Processor Base Power (a.k.a TDP) are dynamically adjusted to a desired system performance and power envelope. Assured Power (cTDP) technology offer opportunities to differentiate system design while running active workloads on select processor SKUs through scalability, configuration and adaptability. The scenarios or methods by which each technology is used are customizable but typically involve changes to PL1 and associated frequencies for the scenario with a resultant change in performance depending on system's usage. Either technology can be triggered by (but are not limited to) changes in OS power policies or hardware events such as docking a system, flipping a switch or pressing a button. Assured Power (cTDP) is designed to be configured dynamically and do not require an operating system reboot.

Note: Assured Power (cTDP) is not battery life improvement technologies.

Assured Power (cTDP)

Note: Assured Power) availability may vary between the different SKUs.

With Assured Power, the processor is capable of altering the maximum sustained power with an alternate processor IA core base frequency. Assured Power allows operation in situations where extra cooling is available or situations where a cooler and quieter mode of operation is desired.

cTDP consists of three modes as shown in the following table.

Assured Power Modes

Mode	Description

Mode	Description
Processor Base Power	<p>The time-averaged power dissipation that the processor is validated to not exceed during manufacturing while executing an Intel-specified high complexity workload at Base Frequency and at the maximum junction temperature as specified in Processor Line Power and Frequency Specifications</p> <p>Note: The System on Chip processor integrates multiple compute cores and I/O on a single package. Platform support for specific usage experiences may require additional concurrency power to be considered when designing the power delivery and thermal sustained system capability.</p>
Maximum Assured Power	<p>Maximum Assured Power (a.k.a cTDP UP) is a specific processor IA core option, where manufacturing confirms logical functionality within the set of operating condition limits specified for the SKU segment.</p> <p>Refer to Processor Line Power and Frequency Specifications. The Maximum Assured Power (a.k.a cTDP-Up) Frequency and corresponding Processor Base Power is higher than the processor IA core Base Frequency and SKU Segment Base on the Processor Base Power.</p>
Minimum Assured Power	<p>Minimum Assured Power (a.k.a cTDP Down) is a specific processor IA core option, where manufacturing confirms logical functionality within the set of operating condition limits specified for the SKU segment.</p> <p>Refer to Processor Line Power and Frequency Specifications. The Minimum Assured Power (a.k.a cTDP-Down) Frequency and corresponding Processor Base Power (a.k.a TDP) is lower than the processor IA core Base Frequency and SKU Segment Processor Base Power.</p>

In each mode, the Intel® Turbo Boost Technology 2.0 power limits are reprogrammed along with a new OS controlled frequency range. The Intel Dynamic Tuning driver assists in Processor Base Power (a.k.a TDP) operation by adjusting processor PL1 dynamically. The Assured Power (cTDP) mode does not change the maximum per-processor IA core turbo frequency.

Thermal Management Features

Occasionally the processor may operate in conditions that are near to its maximum operating temperature. This can be due to internal overheating or overheating within the platform. In order to protect the processor and the platform from thermal failure, several thermal management features exist to reduce package power consumption and thereby temperature in order to remain within normal operating limits. Furthermore, the processor supports several methods to reduce memory power.

Adaptive Thermal Monitor

The purpose of the Adaptive Thermal Monitor is to reduce processor IA core power consumption and temperature until it operates below its maximum operating temperature. Processor IA core power reduction is achieved by:

- Adjusting the operating frequency (using the processor IA core ratio multiplier) and voltage.
- Modulating (starting and stopping) the internal processor IA core clocks (duty cycle).

The Adaptive Thermal Monitor can be activated when the package temperature, monitored by any Digital Thermal Sensor (DTS), meets its maximum operating temperature. The maximum operating temperature implies maximum junction temperature T_{jMAX} .

Reaching the maximum operating temperature activates the Thermal Control Circuit (TCC). When activated the TCC causes both the processor IA core and graphics core to reduce frequency and voltage adaptively. The Adaptive Thermal Monitor will remain active as long as the package temperature remains at its specified limit. Therefore, the Adaptive Thermal Monitor will continue to reduce the package frequency and voltage until the TCC is de-activated.

T_{jMAX} is factory calibrated and is not user configurable. The default value is software visible in the TEMPERATURE_TARGET (0x1A2) MSR, bits [23:16].

The Adaptive Thermal Monitor does not require any additional hardware, software drivers, or interrupt handling routines. It is not intended as a mechanism to maintain processor thermal control to PL1 = Processor Base Power. The system design should provide a thermal solution that can maintain normal operation when PL1 = Processor Base Power within the intended usage range.

Adaptive Thermal Monitor protection is always enabled.

TCC Activation Offset

TCC Activation Offset can be set as an offset from T_{jMAX} to lower the onset of TCC and Adaptive Thermal Monitor. In addition, there is an optional time window (Tau) to manage processor performance at the TCC Activation offset value via an EWMA (Exponential Weighted Moving Average) of temperature. For more information on TCC Activation offset.

TCC Activation Offset with Tau=0

An offset (degrees Celsius) can be written to the TEMPERATURE_TARGET (0x1A2) MSR, bits [29:24], the offset value will be subtracted from the value found in bits [23:16]. When the time window (Tau) is set to zero, there will be no averaging, the offset, will be subtracted from the T_{jMAX} value and used as a new maximum temperature set point for Adaptive Thermal Monitoring. This will have the same behavior as in prior products to have TCC activation and Adaptive Thermal Monitor to occur at this lower target silicon temperature.

If enabled, the offset should be set lower than any other passive protection such as ACPI_PSV trip points

TCC Activation Offset with Tau

To manage the processor with the EWMA (Exponential Weighted Moving Average) of temperature, an offset (degrees Celsius) is written to the TEMPERATURE_TARGET (0x1A2) MSR, bits [29:24], and the time window (Tau) is written to the TEMPERATURE_TARGET (0x1A2) MSR [6:0]. The Offset value will be subtracted from the value found in bits [23:16] and be the temperature.

The processor will manage to this average temperature by adjusting the frequency of the various domains. The instantaneous T_j can briefly exceed the average temperature. The magnitude and duration of the overshoot is managed by the time window value (Tau).

This averaged temperature thermal management mechanism is in addition, and not instead of TjMAX thermal management. That is, whether the TCC activation offset is 0 or not, TCC Activation will occur at TjMAX.

Frequency / Voltage Control

Upon Adaptive Thermal Monitor activation, the processor attempts to dynamically reduce processor temperature by lowering the frequency and voltage operating point. The operating points are automatically calculated by the processor IA core itself and do not require the BIOS to program them as with previous generations of Intel processors. The processor IA core will scale the operating points such that:

- The voltage will be optimized according to the temperature, the processor IA core bus ratio and the number of processor IA cores in deep C-states.
- The processor IA core power and temperature are reduced while minimizing performance degradation.

Once the temperature has dropped below the trigger temperature, the operating frequency and voltage will transition back to the normal system operating point.

Once a target frequency/bus ratio is resolved, the processor IA core will transition to the new target automatically.

- On an upward operating point transition, the voltage transition precedes the frequency transition.
- On a downward transition, the frequency transition precedes the voltage transition.
- The processor continues to execute instructions. However, the processor will halt instruction execution for frequency transitions.

If a processor load-based Enhanced Intel SpeedStep Technology/P-state transition (through MSR write) is initiated while the Adaptive Thermal Monitor is active, there are two possible outcomes:

- If the P-state target frequency is higher than the processor IA core optimized target frequency, the P-state transition will be deferred until the thermal event has been completed.
- If the P-state target frequency is lower than the processor IA core optimized target frequency, the processor will transition to the P-state operating point.

Clock Modulation

If the frequency/voltage changes are unable to end an Adaptive Thermal Monitor event, the Adaptive Thermal Monitor will utilize clock modulation. Clock modulation is done by alternately turning the clocks off and on at a duty cycle (ratio between clock "on" time and total time) specific to the processor. The duty cycle is factory configured to 25% on and 75% off and cannot be modified. The period of the duty cycle is configured to 32 microseconds when the Adaptive Thermal Monitor is active. Cycle times are independent of processor frequency. A small amount of hysteresis has been included to prevent excessive clock modulation when the processor temperature is near its maximum operating temperature. Once the temperature has dropped below the maximum operating temperature, and the hysteresis timer has expired, the Adaptive Thermal Monitor goes inactive and clock modulation ceases. Clock modulation is automatically engaged as part of the Adaptive Thermal Monitor activation when the frequency/voltage targets are at their minimum settings. Processor performance will be decreased when clock modulation is active. Snooping and interrupt processing are performed in the normal manner while the

Adaptive Thermal Monitor is active.

Clock modulation will not be activated by the Package average temperature control mechanism.

Thermal Throttling

As the processor approaches TJ_{MAX} a throttling mechanisms will engage to protect the processor from over-heating and provide control thermal budgets.

Achieving this is done by reducing IA and other subsystem agent's voltages and frequencies in a gradual and coordinated manner that varies depending on the dynamics of the situation. IA frequencies and voltages will be directed down as low as LFM (Lowest Frequency Mode). In relatively rare cases, the processor may take throttle actions on the IO domain, which includes IO fabrics and device throttling, that are designed to avoid shutdown of the system. Further restricts are possible via Thermal Trolling point (TT1) under conditions where thermal budget cannot be re-gained fast enough with voltages and frequencies reduction alone. TT1 keeps the same processor voltage and clock frequencies the same yet skips clock edges to produce effectively slower clocking rates. This will effectively result in observed frequencies below LFM on the Windows PERF monitor.

Digital Thermal Sensor

Each processor has multiple on-die Digital Thermal Sensor (DTS) that detects the processor IA, GT and other areas of interest instantaneous temperature.

Temperature values from the DTS can be retrieved through:

- A software interface using processor Model Specific Register (MSR).
- A processor hardware interface.

When the temperature is retrieved by the processor MSR, it is the instantaneous temperature of the given DTS. When the temperature is retrieved using PECCI, it is the average of the highest DTS temperature in the package over a 256 ms time window. Intel recommends using the PECCI reported temperature for platform thermal control that benefits from averaging, such as fan speed control. The average DTS temperature may not be a good indicator of package Adaptive Thermal Monitor activation or rapid increases in temperature that triggers the Out of Specification status bit within the PACKAGE_THERM_STATUS (0x1B1) MSR and IA32_THERM_STATUS (0x19C) MSR.

Code execution is halted in C1 or deeper C-states. Package temperature can still be monitored through PECCI in lower C-states.

Unlike traditional thermal devices, the DTS outputs a temperature relative to the maximum supported operating temperature of the processor (T_{JMAX}), regardless of TCC activation offset. It is the responsibility of software to convert the relative temperature to an absolute temperature. The absolute reference temperature is readable in the TEMPERATURE_TARGET (0x1A2) MSR. The temperature returned by the DTS is an implied negative integer indicating the relative offset from T_{JMAX}. The DTS does not report temperatures greater than T_{JMAX}. The DTS-relative temperature readout directly impacts the Adaptive Thermal Monitor trigger point. When a package DTS indicates that it has reached the TCC activation (a reading of 0x0, except when the TCC activation offset is changed), the TCC will activate and indicate an Adaptive Thermal Monitor event. A TCC activation will lower both processor IA core and graphics core frequency, voltage, or both. Changes to the temperature can be detected using two programmable thresholds located in the processor thermal MSRs. These thresholds have the capability of generating interrupts using the processor IA core's local APIC. Refer to the *Intel 64 Architectures Software Developer's Manual* for specific register and programming details.

Digital Thermal Sensor Accuracy (T_{accuracy})

The error associated with DTS measurements will not exceed ± 5 °C within the entire operating range.

Fan Speed Control with Digital Thermal Sensor

Digital Thermal Sensor based fan speed control (T_{FAN}) is a recommended feature to achieve optimal thermal performance. At the T_{FAN} temperature, Intel recommends full cooling capability before the DTS reading reaches T_{JMAX} .

PROCHOT# Signal

The PROCHOT# (processor hot) signal is asserted by the processor when the TCC is active. Only a single PROCHOT# pin exists at a package level. When any DTS temperature reaches the TCC activation temperature, the PROCHOT# signal will be asserted. PROCHOT# assertion policies are independent of Adaptive Thermal Monitor enabling.

The PROCHOT# signal can be configured to the following modes:

- **Input Only:** PROCHOT is driven by an external device.
- **Output Only:** PROCHOT is driven by processor.
- **Bi-Directional:** Both Processor and external device can drive PROCHOT signal

PROCHOT Input Only

The PROCHOT# signal should be set to input only by default. In this state, the processor will only monitor PROCHOT# assertions and respond by setting the maximum frequency to 10Khz.

The following two features are enabled when PROCHOT is set to Input only:

- **Fast PROCHOT:** Respond to PROCHOT# within 1uS of PROCHOT# pin assertion, reducing the processor power.
- **PROCHOT Demotion Algorithm:** designed to improve system performance during multiple PROCHOT assertions.

PROCHOT Demotion Description

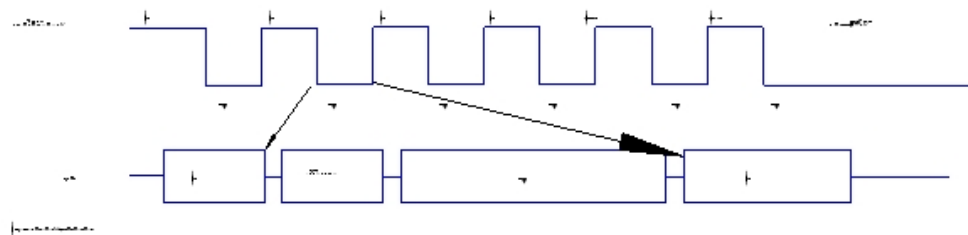

PROCHOT Output Only

Legacy state, PROCHOT is driven by the processor to external device.

Bi-Directional PROCHOT#

By default, the PROCHOT# signal is set to input only. When configured as an input or bi-directional signal, PROCHOT# can be used for thermally protecting other platform components should they overheat as well. When PROCHOT# is driven by an external device:

- The package will immediately transition to the lowest P-State (Pn) supported by the processor IA cores and graphics cores. This is contrary to the internally-generated Adaptive Thermal Monitor response.
- Clock modulation is not activated.

The processor package will remain at the lowest supported P-state until the system de-asserts PROCHOT#. The processor can be configured to generate an interrupt upon assertion and de-assertion of the PROCHOT# signal.

When PROCHOT# is configured as a bi-directional signal and PROCHOT# is asserted by the processor, it is impossible for the processor to detect a system assertion of PROCHOT#. The system assertion will have to wait until the processor de-asserts PROCHOT# before PROCHOT# action can occur due to the system assertion. While the processor is hot and asserting PROCHOT#, the power is reduced but the reduction rate is slower than the system PROCHOT# response of < 100 us. The processor thermal control is staged in smaller increments over many milliseconds. This may cause several milliseconds of delay to a system assertion of PROCHOT# while the output function is asserted.

PROCHOT Demotion Algorithm

PROCHOT demotion algorithm is designed to improve system performance following multiple Platform PROCHOT consecutive assertions. During each PROCHOT assertion processor will eventually transition to the lowest P-State (Pn) supported by the processor IA cores and graphics cores (LFM). When detecting several PROCHOT consecutive assertions the processor will reduce the max frequency in order to reduce the PROCHOT assertions events. The processor will keep reducing the frequency until no consecutive assertions detected. The processor will raise the frequency if no consecutive PROCHOT assertion events will occur. PROCHOT demotion algorithm enabled only when the PROCHOT is configured as input.

Voltage Regulator Protection using PROCHOT#

PROCHOT# may be used for thermal protection of voltage regulators (VR). System designers can create a circuit to monitor the VR temperature and assert PROCHOT# and, if enabled, activate the TCC when the temperature limit of the VR is reached. When PROCHOT# is configured as a bi-directional or input only signal, if the system assertion of PROCHOT# is recognized by the processor, results in power reduction. Power reduction down to LFM and duration of the platform PROCHOT# assertion supported by the processor IA cores and graphics cores. Systems should still provide proper cooling for the VR and rely on bi-directional PROCHOT# only as a backup in case of system cooling failure. Overall, the system thermal design should allow the power delivery circuitry to operate within its temperature specification even while the processor is operating at its Processor Base Power.

Note: During PROCHOT demotion the core frequency may be reduced below LFM for several uSec.

Thermal Solution Design and PROCHOT# Behavior

With a properly designed and characterized thermal solution, it is anticipated that PROCHOT# will only be asserted for very short periods of time when running the most power intensive applications. The processor performance impact due to these brief periods of TCC activation is expected to be so minor that it would be immeasurable. However, an under-designed thermal solution that is not able to prevent excessive assertion of PROCHOT# in the anticipated ambient environment may:

- Cause a noticeable performance loss.
- Result in prolonged operation at or above the specified maximum junction temperature and affect the long-term reliability of the processor.
- May be incapable of cooling the processor even when the TCC is active continuously (in extreme situations).

Low-Power States and PROCHOT# Behavior

Depending on package power levels during package C-states, outbound PROCHOT# may de-assert while the processor is idle as power is removed from the signal. Upon wake up, if the processor is still hot, the PROCHOT# will re-assert, although typically package idle state residency should resolve any thermal issues. The PECCI interface is fully operational during all C-states and it is expected that the platform continues to manage processor IA core and package thermals even during idle states by regularly polling for thermal data over PECCI.

THRMTRIP# Signal

Regardless of enabling the automatic or on-demand modes, in the event of a catastrophic cooling failure, the package will automatically shut down when the silicon has reached an elevated temperature that risks physical damage to the product. At this point, the THRMTRIP# signal will go active.

Critical Temperature Detection

Critical Temperature detection is performed by monitoring the package temperature. This feature is intended for graceful shutdown before the THRMTRIP# is activated. However, the processor execution is not guaranteed between critical temperature and THRMTRIP#. If the Adaptive Thermal Monitor is triggered and the temperature remains high, a critical temperature status and sticky bit are latched in the PACKAGE_THERM_STATUS (0x1B1) MSR and the condition also generates a thermal interrupt, if enabled.

On-Demand Mode

The processor provides an auxiliary mechanism that allows system software to force the processor to reduce its power consumption using clock modulation. This mechanism is referred to as “On-Demand” mode and is distinct from Adaptive Thermal Monitor and bi-directional PROCHOT#. The processor platforms should not rely on software usage of this mechanism to limit the processor temperature. On-Demand Mode can be accomplished using processor MSR or chipset I/O emulation. On-Demand Mode may be used in conjunction with the Adaptive Thermal Monitor. However, if the system software tries to enable On-Demand mode at the same time the TCC is engaged, the factory configured the duty cycle of the TCC will override the duty cycle selected by the On-Demand mode. If the I/O based and MSR-based On-Demand modes are in conflict, the duty cycle selected by the I/O emulation-based On-Demand mode will take precedence over the MSR-based On-Demand Mode.

MSR Based On-Demand Mode

If Bit 4 of the IA32_CLOCK_MODULATION MSR is set to 1, the processor will immediately reduce its power consumption using modulation of the internal processor IA core clock, independent of the processor temperature. The duty cycle of the clock modulation is programmable using bits [3:1] of the same IA32_CLOCK_MODULATION MSR. In this mode, the duty cycle can be programmed in either 12.5% or 6.25% increments (discoverable using CPUID). Thermal throttling using this method will modulate each processor IA core's clock independently.

I/O Emulation-Based On-Demand Mode

I/O emulation-based clock modulation provides legacy support for operating system software that initiates clock modulation through I/O writes to ACPI defined processor clock control registers on the chipset (PROC_CNT). Thermal throttling using this method will modulate all processor IA cores simultaneously.

Intel® Memory Thermal Management

DRAM Thermal Aggregation

P-Unit firmware is responsible for aggregating DRAM temperature sources into a per-DIMM reading as well as an aggregated virtual 'max' sensor reading. At reset, MRC communicates to the MC the valid channels and ranks as well as DRAM type. At that time, Punit firmware sets up a valid channel and rank mask that is then used in the thermal aggregation algorithm to produce a single maximum temperature

DRAM Thermal Monitoring

- DRAM thermal sensing Periodic DDR thermal reads from DDR
- DRAM thermal calculation Punit reads of DDR thermal information direct from the memory controller (MR4 or MPR) Punit estimation of a virtual maximum DRAM temperature based on per-rank readings. Application of thermal filter to the virtual maximum temperature.

DRAM Refresh Rate Control

The MRC will natively interface with MR4 or MPR readings to adjust DRAM refresh rate as needed to maintain data integrity. This capability is enabled by default and occurs automatically. Direct override of this capability is available for debug purposes, but this cannot be adjusted during runtime.

Processor Line Thermal and Power Specifications

The following notes apply to [Processor Line Power and Frequency Specifications, Table: Package Turbo Specifications \(S / HX - Processor Lines\)](#), [Table: Package Turbo Specifications \(H/P/U - Processor Lines\)](#)

Note	Definition
1	The Processor Base Power (a.k.a TDP) and Assured Power (cTDP) values are the average power dissipation in junction temperature operating condition limit, for the SKU Segment and Configuration, for which the processor is validated during manufacturing when executing an associated Intel-specified high-complexity workload at the processor IA core frequency corresponding to the configuration and SKU.
2	Thermal workload (Processor Base Power (a.k.a TDP)) may consist of a combination of processor IA core intensive and graphics core intensive applications.
3	Can be modified at runtime by MSR writes, with MMIO and with PECL commands.
4	'Turbo Time Parameter' is a mathematical parameter (units of seconds) that controls the processor turbo algorithm using a moving average of energy usage. Do not set the Turbo Time Parameter to a value less than 0.1 seconds. refer to Platform Power Control for further information.
5	The shown limit is a time averaged-power, based upon the Turbo Time Parameter. Absolute product power may exceed the set limits for short durations or under virus or uncharacterized workloads.
6	The Processor will be controlled to a specified power limit as described in Intel® Turbo Boost Technology 2.0 Power Monitoring . If the power value and/or 'Turbo Time Parameter' is changed during runtime, it may take a short period of time (approximately 3 to 5 times the 'Turbo Time Parameter') for the algorithm to settle at the new control limits.
7	This is a hardware default setting and not a behavioral characteristic of the part.
8	For controllable turbo workloads, the PL2 limit may be exceeded for up to 10ms.
9	LPM power level is an opportunistic power and is not a guaranteed value as usages and implementations may vary.

Note	Definition
10	Power limits may vary depending on if the product supports the Minimum Assured Power (cTDP Down) and/or Maximum Assured Power (cTDP Up) modes. Default power limits can be found in the PKG_PWR_SKU MSR (614h).
11	The processor die do not reach maximum sustained power simultaneously since the sum of the 2 die's estimated power budget is controlled to be equal to or less than the package Processor Base Power (a.k.a TDP) (PL1) limit.
12	Minimum Assured Power(cTDP Down) power is based on 96EU equivalent graphics configuration. Minimum Assured Power(cTDP Down) does not decrease the number of active Processor Graphics EUs but relies on Power Budget Management (PL1) to achieve the specified power level.
13	May vary based on SKU.
14	<ul style="list-style-type: none"> • The formula of $PL2=PL1*1.25$ is the hardware. • PL2- SoC opportunistic higher Average Power with limited duration controlled by Tau_PL1 setting, the larger the Tau, the longer the PL2 duration. • A recommendation to set all power delivery especially PL2 and PL1 based on platform power and thermal capability via BIOS.
15	Processor Base Power (a.k.a TDP) workload does not reflect various I/O connectivity cases such as Thunderbolt.
16	Hardware default of PL1 Tau=1s, By including the benefits available from power and thermal management features the recommended is to use PL1 Tau=28s.

Processor Line Power and Frequency Specifications

Processor Base Power (TDP) and Frequency Specifications(H-Processor Line, P-Processor Line)

Segment and Package	Processor IA/GT Cores, and Processor Base Power	Configuration	Processor IA Core Frequency	Graphics Core Frequency	Processor Base Power [w]	Notes
H-Processor Line BGA	6+8 Core 45W	Maximum Assured Power	2.7GHz up to 2.9GHz	300MHz	65	1,9,10,11,12,15
		P-Core	2.3GHz up to 2.5GHz		45	
		E-Core	1.7GHz up to 1.8GHz		35	
		Minimum Assured Power	1.5GHz up to 1.9GHz		N/A	
		LFM	400MHZ	100MHz	N/A	
H-Processor Line BGA	6+4 Core 45W	Maximum Assured Power	2.7GHz	300MHz	65	1,9,10,11,12,15
		P-Core	2.3GHz		45	
		E-Core	1.7GHz		35	
		Minimum Assured Power	1.5GHz		N/A	
		LFM	400MHZ	100MHz	N/A	
H-Processor Line BGA	4+8 Core 45W	Maximum Assured Power	3.1GHz up to 3.2GHz	300MHz	65	

BGA



Segment and Package	Processor IA/GT Cores, and Processor Base Power	Configuration	Processor IA Core Frequency	Graphics Core Frequency	Processor Base Power [w]	Notes
		P-Core	2.5GHz up to 2.7GHz		45	
		E-Core	1.8GHz up to 2.0GHz			
		Minimum Assured Power	1.7GHz up to 2.2GHz		35	
		LFM	400MHZ		100MHz	
H-Processor Line BGA	4+4 Core 45W	Maximum Assured Power	2.5GHz	300MHz	65	1,9, 10,1 1,12 , 15
		P-Core	2.0GHz		45	
		E-Core	1.5GHz			
		Minimum Assured Power	1.1GHz		35	
		LFM	400MHZ		100MHz	
P-Processor Line BGA	6+8 Core 28W	Maximum Assured Power	2GHz	300MHz	35	1,9, 10,1 1,12 , 15
		P-Core	1.8GHz		28	
		E-Core	1.3GHz			

Segment and Package	Processor IA/GT Cores, and Processor Base Power	Configuration	Processor IA Core Frequency	Graphics Core Frequency	Processor Base Power [w]	Notes
		Minimum Assured Power	1.4GHz		20	
		LFM	400MHZ	100MHz	N/A	
P-Processor Line BGA	4+8 Core 28W	Maximum Assured Power	2.1GHz up to 2.5GHz	300MHz	35	1,9,10,11,12,15
		P-Core	1.7GHz up to 2.2GHz		28	
		E-Core	1.2GHz up to 1.6GHz		20	
		Minimum Assured Power	1.4GHz up to 1.6GHz		N/A	
		LFM	400MHZ		100MHz	
P-Processor Line BGA	2+8 Core 28W	Maximum Assured Power	2GHz	300MHz	35	1,9,10,11,12,15
		P-Core	1.5GHz		28	
		E-Core	1.1Ghz		20	
		Minimum Assured Power	1.0GHz			



Segment and Package	Processor IA/GT Cores, and Processor Base Power	Configuration	Processor IA Core Frequency	Graphics Core Frequency	Processor Base Power [w]	Notes
		LFM	400MHZ	100MHz	N/A	

Processor Base Power (TDP) and Frequency Specifications(U-Processor Line)

Segment and Package	Processor IA/GT Cores, and Processor Base Power	Configuration	Processor IA Core Frequency	Graphics Core Frequency	Processor Base Power [w]	Notes
U-Processor Line BGA	2+8 Core 15W	Maximum Assured Power	2.5GHz up to 2.7GHz	300MHz	28	1,9, 10,1 1,12 , 15
		P-Core	1.3GHz up to 1.8GHz		15	
		E-Core	0.9GHz up to 1.3GHz		12	
		Minimum Assured Power	0.8GHz up to 1.3GHz			
		LFM	400MHZ	100MHz	N/A	
U-Processor Line BGA	2+4 Core 15W	Maximum Assured Power	2.5GHz	300MHz	28	1,9, 10,1 1,12 , 15
		P-Core	1.2GHz		15	
		E-Core	0.9GHz			

Segment and Package	Processor IA/GT Cores, and Processor Base Power	Configuration	Processor IA Core Frequency	Graphics Core Frequency	Processor Base Power [w]	Notes
		Minimum Assured Power	0.8GHz		12	
		LFM	400MHZ	100MHz	N/A	
U-Processor Line BGA	1+4 Core 15W	Maximum Assured Power	2.5GHz	300MHz	28	1,9,10,11,12,15
		P-Core	1.1GHz up to 1.2GHz		15	
		E-Core	0.9GHz			
		Minimum Assured Power	0.8GHz up to 0.9GHz		12	
		LFM	400MHZ	100MHz	N/A	

Processor Base Power (TDP) and Frequency Specifications (U 9W-Processor Line)

Segment and Package	Processor IA /GT Cores, and Processor Base Power	Configuration	Processor IA Core Frequency	Graphics Core Frequency	Processor Base Power [w]	Notes
U-Processor Line BGA	2+8 Core 9W	Maximum Assured Power	1.7GHz up to 1.9GHz	300MHz	15	1,9,10,11,12,15



Segment and Package	Processor IA /GT Cores, and Processor Base Power	Configuration	Processor IA Core Frequency	Graphics Core Frequency	Processor Base Power [w]	Notes
		P-Core	1.0GHz up to 1.1GHz		9	
		E-Core	0.7GHz up to 0.8GHz			
		LFM	400MHZ	100MHZ	N/A	
U-Processor Line BGA	2+4 Core 9W	Maximum Assured Power	1.7GHz	300MHZ	15	1,9,10,11,12,15
		P-Core	1.0GHz		9	
		E-Core	0.7GHz			
		LFM	400MHZ	100MHZ	N/A	
U-Processor Line BGA	1+4 Core 9W	Maximum Assured Power	1.6GHz	300MHZ	15	1,9,10,11,12,15
		P-Core	1.0GHz		9	
		E-Core	0.7GHz			
		LFM	400MHZ	100MHZ	N/A	

Processor Base Power (TDP) and Frequency Specifications (S-Processor Line)

Segment and Package	Processor IA/GT Cores, and Processor Base Power	Configuration	Processor IA Core Frequency	Graphics Core Frequency	Processor Base Power [w]	Notes
S-Processor Line LGA	8+8 Core 150W	P-Core	3.4 GHz	300MHZ	150	1,9, 10, 11, 12, 15
		E-Core	2.5 GHz			
		LFM	400MHZ	300MHZ	N/A	
S-Processor Line LGA	8+8 Core 125W	P-Core	3.2GHz	300MHZ	125	1,9, 10, 11, 12, 15
		E-Core	2.4GHz			
		LFM	400MHZ	300MHZ	N/A	
S-Processor Line LGA	8+4 Core 125W	P-Core	3.6GHz	300MHZ	125	1,9, 10, 11, 12, 15
		E-Core	2.7GHz			
		LFM	400MHZ	300MHZ	N/A	
S-Processor Line LGA	6+4 Core 125W	P-Core	3.7GHz	300MHZ	125	1,9, 10, 11, 12, 15
		E-Core	2.8GHz			
		LFM	400MHZ	300MHZ	N/A	



Segment and Package	Processor IA/GT Cores, and Processor Base Power	Configuration	Processor IA Core Frequency	Graphics Core Frequency	Processor Base Power [w]	Notes
S-Processor Line LGA	8+8 Core 65W	P-Core	2.4GHz	300MHZ	65	1,9, 10, 11, 12, 15
		E-Core	1.8GHz			
		LFM	400MHZ		N/A	
S-Processor Line LGA	8+4 Core 65W	P-Core	2.1GHz	300MHZ	65	1,9, 10, 11, 12, 15
		E-Core	1.6GHz			
		LFM	400MHZ		N/A	
S-Processor Line LGA	8+8 Core 35W	P-Core	1.4GHz	300MHZ	35	1,9, 10, 11, 12, 15
		E-Core	1GHz			
		LFM	400MHZ		N/A	
S-Processor Line LGA	8+4 Core 35W	P-Core	1.4GHz	300MHZ	35	1,9, 10, 11, 12, 15
		E-Core	1GHz			
		LFM	400MHZ		N/A	

Segment and Package	Processor IA/GT Cores, and Processor Base Power	Configuration	Processor IA Core Frequency	Graphics Core Frequency	Processor Base Power [w]	Notes
S-Processor Line LGA	6+0 Core 35W	P-Core	1.8GHz up to 2.1GHz	300MHZ	35	1,9, 10, 11, 12, 15
		LFM	1GHz		N/A	
S-Processor Line LGA	4+0 Core 35W	P-Core	2.2GHz up to 2.3GHz	300MHZ	35	1,9, 10, 11, 12, 15
		LFM	400MHZ		N/A	
S-Processor Line LGA	2+0 Core 35W	P-Core	2.8GHz up to 3.1GHz	300MHZ	35	1,9, 10, 11, 12, 15
		LFM	400MHZ		N/A	
S-Processor Line LGA	6+0 Core 65W	P-Core	2.5GHz up to 3.3GHz	300MHZ	65	1,9, 10, 11, 12, 15
		LFM	400MHZ		N/A	
S-Processor Line LGA	4+0 Core 60W	P-Core	3.3GHz up to 3.5GHz	300MHZ	60	1,9, 10, 11, 12, 15
		LFM	400MHZ		N/A	
S-Processor Line LGA	4+0 Core 58W	P-Core	3.3GHz	300MHZ	58	1,9, 10, 11, 12, 15
		LFM	400MHZ		N/A	



Segment and Package	Processor IA/GT Cores, and Processor Base Power	Configuration	Processor IA Core Frequency	Graphics Core Frequency	Processor Base Power [w]	Notes
S-Processor Line LGA	2+0 Core 46W	P-Core	3.4GHz up to 3.7GHz	300MHZ	46	1,9, 10, 11, 12, 15
		LFM	400MHZ		N/A	

Processor Base Power (TDP) and Frequency Specifications (HX-Processor Line)

Segment and Package	Processor IA/GT Cores, and Processor Base Power	Configuration	Processor IA Core Frequency	Graphics Core Frequency	Processor Base Power [w]	Notes
HX-Processor Line SBGA	8+8 Core 55W	P-Core	2 GHz up to 2.3 GHz	300 MHz	55 W	1,9, 10,1 1,12 , 15
		E-Core	1.5 GHz up to 1.7 GHz		45 W	
		Minimum Assured Power (Configurable TDP-Down)	1.7 GHz up to 2 GHz			
		LFM	0.8 GHz		N/A	
HX-Processor Line SBGA	4+8 Core 55W	P-Core	2.5 GHz	300 MHz	55 W	

Segment and Package	Processor IA/GT Cores, and Processor Base Power	Configuration	Processor IA Core Frequency	Graphics Core Frequency	Processor Base Power [w]	Notes
		E-Core	1.8 GHz		45 W	
		Minimum Assured Power (Configurable TDP-Down)	2.1 GHz			
		LFM	0.8 GHz		N/A	

Processor Line Thermal and Power

Package Turbo Specifications (H/P/U -Processor Lines)

Segment and Package	Processor IA Cores, Graphics, Configuration and Processor Base Power (a.k.a. TDP)	Parameter	Minimum Value	Recommended Value	Tau MSR Max Value	Units	Notes
H-Processor Line	6+8 Core 45W	Power Limit 1 Time (PL1 Tau)	0.1	56	448	S	3,4,5,6,7,8,14,16,17
		Power Limit 1 (PL1)	N/A	45	N/A	W	



Segment and Package	Processor IA Cores, Graphics, Configuration and Processor Base Power (a.k.a. TDP)	Parameter	Minimum Value	Recommended Value	Tau MSR Max Value	Units	Notes
		Power Limit 2 (PL2)	N/A	115	N/A	W	
H-Processor Line	6+4 Core 45W	Power Limit 1 Time (PL1 Tau)	0.1	56	448	S	3,4,5,6,7,8,14,16,17
		Power Limit 1 (PL1)	N/A	45	N/A	W	
		Power Limit 2 (PL2)	N/A	115	N/A	W	
H-Processor Line	4+8 Core 45W	Power Limit 1 Time (PL1 Tau)	0.1	56	448	S	3,4,5,6,7,8,14,16,17
		Power Limit 1 (PL1)	N/A	45	N/A	W	
		Power Limit 2 (PL2)	N/A	95	N/A	W	

Segment and Package	Processor IA Cores, Graphics, Configuration and Processor Base Power (a.k.a. TDP)	Parameter	Minimum	Recommended Value	Tau MSR Max Value	Units	Notes
H-Processor Line	4+4 Core 45W	Power Limit 1 Time (PL1 Tau)	0.1	56	448	S	3,4,5,6,7,8,14,16,17
		Power Limit 1 (PL1)	N/A	45	N/A	45	
		Power Limit 2 (PL2)	N/A	95	N/A	Note	
P-Processor Line	6+8 Core 28W	Power Limit 1 Time (PL1 Tau)	0.1	28	448	S	3,4,5,6,7,8,14,16,17
		Power Limit 1 (PL1)	N/A	28	N/A	W	
		Power Limit 2 (PL2)	N/A	Note	N/A	W	
P-Processor Line	4+8 Core 28W	Power Limit 1 Time (PL1 Tau)	0.1	28	448	S	3,4,5,6,7,8,14,16,17



Segment and Package	Processor IA Cores, Graphics, Configuration and Processor Base Power (a.k.a. TDP)	Parameter	Minimum Value	Recommended Value	Tau MSR Max Value	Units	Notes
		Power Limit 1 (PL1)	N/A	28	N/A	W	
		Power Limit 2 (PL2)	N/A	Note	N/A	W	
P-Processor Line	2+8 Core 28W	Power Limit 1 Time (PL1 Tau)	0.1	28	448	S	3,4,5,6,7,8,14,16,1
		Power Limit 1 (PL1)	N/A	28	N/A	W	
		Power Limit 2 (PL2)	N/A	Note	N/A	W	
U-Processor Line	2+8 Core 15W	Power Limit 1 Time (PL1 Tau)	0.1	28	448	S	3,4,5,6,7,8,14,16,17
		Power Limit 1 (PL1)	N/A	15	N/A	W	

Segment and Package	Processor IA Cores, Graphics, Configuration and Processor Base Power (a.k.a. TDP)	Parameter	Minimum Value	Recommended Value	Tau MSR Max Value	Units	Notes
		Power Limit 2 (PL2)	N/A	Note	N/A	W	
U-Processor Line	2+4 Core 15W	Power Limit 1 Time (PL1 Tau)	0.1	28	448	S	3,4,5,6,7,8,14,16,1
		Power Limit 1 (PL1)	N/A	15	N/A	W	
		Power Limit 2 (PL2)	N/A	Note	N/A	W	
U-Processor Line	1+4 Core 15W	Power Limit 1 Time (PL1 Tau)	0.1	28	448	S	3,4,5,6,7,8,14,16,1
		Power Limit 1 (PL1)	N/A	15	N/A	W	
		Power Limit 2 (PL2)	N/A	Note	N/A	W	



Segment and Package	Processor IA Cores, Graphics, Configuration and Processor Base Power (a.k.a. TDP)	Parameter	Minimum Value	Recommended Value	Tau MSR Max Value	Units	Notes
U-Processor Line	2+8 Core 9W	Power Limit 1 Time (PL1 Tau)	0.1	28	448	S	3,4,5,6,7,8,14,16,17
		Power Limit 1 (PL1)	N/A	9	N/A	W	
		Power Limit 2 (PL2)	N/A	Note	N/A	W	
U-Processor Line	2+4 Core 9W	Power Limit 1 Time (PL1 Tau)	0.1	28	448	S	3,4,5,6,7,8,14,16,1
		Power Limit 1 (PL1)	N/A	9	N/A	W	
		Power Limit 2 (PL2)	N/A	Note	N/A	W	
U-Processor Line	1+4 Core 9W	Power Limit 1 Time (PL1 Tau)	0.1	28	448	S	3,4,5,6,7,8,14,16,1

Segment and Package	Processor IA Cores, Graphics, Configuration and Processor Base Power (a.k.a. TDP)	Parameter	Recommended Value		Tau MSR Max Value	Units	Notes
			Minimum	Value			
		Power Limit 1 (PL1)	N/A	9	N/A	W	
		Power Limit 2 (PL2)	N/A	Note	N/A	W	

Notes:

- No Specifications for Min/Max PL1/PL2 values.
- Hardware default of PL1 Tau=1s, By including the benefits available from power and thermal management features the recommended is to use PL1 Tau=28s.
- PL2- SoC opportunistic higher Average Power – Reactive, Limited Duration controlled by Tau_PL1 setting.
- PL1 Tau - PL1 average power is controlled via PID algorithm with this Tau, The larger the Tau, the longer the PL2 duration.
- System cooling solution and designs found to not being able to support the Performance Tau PL1, adjust the TauPL1 to cooling capability.
- A recommendation to set all power delivery especially PL2 and PL1 based on platform power and thermal capability via BIOS.

Junction Temperature Specifications (H / HX /P/U - Processor Lines)

Segment	Symbol	Package Turbo Parameter	Temperature Range		Processor Base Power (a.k.a TDP) Specification Temperature Range		Units	Notes
			Minimum	Maximum	Minimum	Maximum		



Segment	Symbol	Package Turbo Parameter	Temperature Range		Processor Base Power (a.k.a TDP) Specification Temperature Range		Units	Notes
			Minimum	Maximum	Minimum	Maximum		
HX-Processor Line SBGA	Tj	Junction temperature limit	0	100	0	100	°C	1, 3
H Processor Line BGA	Tj	Junction temperature limit	0	100	35	100	°C	1, 3
P/U 15W - Processor Line BGA	Tj	Junction temperature limit	0	100	35	100	°C	1, 3
U 9W-Processor Line BGA	Tj	Junction temperature limit	0	100	35	90	°C	1, 2,3

Notes:

The thermal solution needs to ensure that the processor temperature does not

1. exceed the Processor Base Power Specification Temperature.
2. For M - Processor line specification, thermal designs should ensure a Tjmax of 90C in sustained Processor Base Power (a.k.a TDP) workload for guaranteed performance. TCC Offset=10 and Tau value should be programmed into MSR 1A2h. The recommended TCC_Offset averaging Tau is 5s. Operating the part above 90C will result in higher power. Refer to Turbo Implementation Guide (TIG) for evaluate TCC_Offset averaging Tau values.
3. The processor junction temperature is monitored by Digital Temperature Sensors (DTS). For DTS accuracy, refer to [Digital Thermal Sensor](#).

Package Turbo Specifications (S / HX - Processor Lines)

Segment and Package	Processor IA Cores, Graphics, Configuration and Processor Base (a.k.a. Package TDP)	Parameter	Recommended		Tau MSR Max Value	Units	Notes
			Minimum	Value			
S-Processor Line LGA	8+8 Core 150W	Power Limit 1 Time (PL1 Tau)	0.1	56	448	S	3,4,5,6,7,8,14,16,17
		Power Limit 1 (PL1)	N/A	150	N/A	W	
		Power Limit 2 (PL2)	N/A	241	N/A	W	
	8+8 Core 125W	Power Limit 1 Time (PL1 Tau)	0.1	56	448	S	3,4,5,6,7,8,14,16,17
		Power Limit 1 (PL1)	N/A	125	N/A	W	
		Power Limit 2 (PL2)	N/A	241	N/A	W	



Segment and Package	Processor IA Cores, Graphics, Configuration and Processor Base Power (a.k.a TDP)	Parameter	Recommended		Tau MSR Max	Units	Notes
			Minimum Value	Value	Value		
	8+4 Core 125W	Power Limit 1 Time (PL1 Tau)	0.1	56	448	S	3,4,5,6,7,8,14,16,17
		Power Limit 1 (PL1)	N/A	125	N/A	W	
		Power Limit 2 (PL2)	N/A	190	N/A	W	
	6+4 Core 125W	Power Limit 1 Time (PL1 Tau)	0.1	56	448	S	3,4,5,6,7,8,14,16,17
		Power Limit 1 (PL1)	N/A	125	N/A	W	
		Power Limit 2 (PL2)	N/A	150	N/A	W	
S-Processor Line LGA	8+8 Core 65W	Power Limit 1 Time (PL1 Tau)	0.1	28	448	S	3,4,5,6,7,8,14,16,17

Segment and Package	Processor IA Cores, Graphics, Configuration and Processor Base (a.k.a TDP)	Parameter	Recommended		Tau MSR	Units	Notes	
			Minimum Value	Value	Max Value			
		Power Limit 1 (PL1)	N/A	65	N/A	W		
		Power Limit 2 (PL2)	N/A	202	N/A	W		
	8+4 Core 65W	Power Limit 1 Time (PL1 Tau)	0.1	28	448	S		3,4,5,6,7,8,14,16,17
		Power Limit 1 (PL1)	N/A	65	N/A	W		
		Power Limit 2 (PL2)	N/A	180	N/A	W		
	8+8 Core 35W	Power Limit 1 Time (PL1 Tau)	0.1	28	448	S		3,4,5,6,7,8,14,16,17
Power Limit 1 (PL1)		N/A	35	N/A	W			



Segment and Package	Processor IA Cores, Graphics, Configuration and Processor Base Power (a.k.a TDP)	Parameter	Minimum Value	Recommended Value	Tau MSR Max Value	Units	Notes
		Power Limit 2 (PL2)	N/A	106	N/A	W	
8+4 Core 35W		Power Limit 1 Time (PL1 Tau)	0.1	28	448	S	3,4,5,6,7,8,14,16,17
		Power Limit 1 (PL1)	N/A	35	N/A	W	
		Power Limit 2 (PL2)	N/A	99	N/A	W	
6+0 Core 35W		Power Limit 1 Time (PL1 Tau)	0.1	28	448	S	3,4,5,6,7,8,14,16,17
		Power Limit 1 (PL1)	N/A	35	N/A	W	
		Power Limit 2 (PL2)	N/A	74	N/A	W	

Segment and Package	Processor IA Cores, Graphics, Configuration and Processor Base Power (a.k.a TDP)	Parameter	Recommended		Tau MSR Max	Units	Notes
			Minimum Value	Value	Value		
4+0 Core 35W		Power Limit 1 Time (PL1 Tau)	0.1	28	448	S	3,4,5,6,7,8,14,16,17
		Power Limit 1 (PL1)	N/A	35	N/A	W	
		Power Limit 2 (PL2)	N/A	69	N/A	W	
2+0 Core 35W		Power Limit 1 Time (PL1 Tau)	0.1	28	448	S	3,4,5,6,7,8,14,16,17
		Power Limit 1 (PL1)	N/A	35	N/A	W	
		Power Limit 2 (PL2)	N/A	35	N/A	W	
2+0 Core 46W		Power Limit 1 Time (PL1 Tau)	0.1	28	448	S	3,4,5,6,7,8,14,16,17



Segment and Package	Processor IA Cores, Graphics, Configuration and Processor Base Power (a.k.a TDP)	Parameter	Minimum Value	Recommended Value	Tau MSR Max Value	Units	Notes
		Power Limit 1 (PL1)	N/A	46	N/A	W	
		Power Limit 2 (PL2)	N/A	46	N/A	W	
	6+0 Core 65W	Power Limit 1 Time (PL1 Tau)	0.1	28	448	S	
		Power Limit 1 (PL1)	N/A	65	N/A	W	3,4,5,6,7,8,14,16,17
		Power Limit 2 (PL2)	N/A	117	N/A	W	
	4+0 Core 60W	Power Limit 1 Time (PL1 Tau)	0.1	28	448	S	
		Power Limit 1 (PL1)	N/A	60	N/A	W	3,4,5,6,7,8,14,16,17

Segment and Package	Processor IA Cores, Graphics, Configuration and Processor Base Power (a.k.a TDP)	Parameter	Minimum Value	Recommended Value	Tau MSR	Units	Notes
					Max Value		
	4+0 Core 58W	Power Limit 2 (PL2)	N/A	89	N/A	W	
		Power Limit 1 Time (PL1 Tau)	0.1	28	448	S	3,4,5,6,7,8,14,16,17
		Power Limit 1 (PL1)	N/A	58	N/A	W	
		Power Limit 2 (PL2)	N/A	89	N/A	W	
HX-Processor Line SBGA	8+8 Core 55W	Power Limit 1 Time (PL1 Tau)	0.1	56	448	S	3,4,5,6,7,8,14,16
		Power Limit 1 (PL1)	N/A	55	N/A	W	
		Power Limit 2 (PL2)	N/A	Note	N/A	W	



Segment and Package	Processor IA Cores, Graphics, Configuration and Processor Base Power (a.k.a TDP)	Parameter	Minimum Value	Recommended Value	Tau MSR Max Value	Units	Notes
HX-Processor Line SBGA	4+8 Core 55W	Power Limit 1 Time (PL1 Tau)	0.1	56	448	S	3,4,5,6,7,8,14,16
		Power Limit 1 (PL1)	N/A	55	N/A	W	
		Power Limit 2 (PL2)	N/A	Note	N/A	W	

Notes:

- No Specifications for Min/Max PL1/PL2 values.
- Hardware default of PL1 Tau=1s, By including the benefits available from power and thermal management features the recommended is to use PL1 Tau=28s.
- PL2- SoC opportunistic higher Average Power – Reactive, Limited Duration controlled by Tau_PL1 setting.
- PL1 Tau - PL1 average power is controlled via PID algorithm with this Tau. The larger the Tau, the longer the PL2 duration.
- System cooling solution and designs found to not being able to support the Performance TauPL1, adjust the TauPL1 to cooling capability.

Low Power and TTV

Low Power and TTV Specifications (S-Processor Line LGA)

Processor IA Cores, Graphics Configuration and Processor Base Power (a.k.a TDP)	PCG7	Maximum Power Package C7 (W) ^{1,4,5}	Maximum Power Package C8 (W) ^{1,4,5}	TTV Processor Base Power (a.k.a TDP) (W) ^{6,7}	Min TCASE (°C)	Maximum TTV TCASE (°C)	
8+8 Core 150W	202 OE	N/A	N/A	150	0	59.2	
8+8 Core 125W	202 OA	N/A	N/A	125	0	61.9	
8+4 Core 125W		N/A	N/A	125	0	61.9	
6+4 Core 125W		N/A	N/A	125	0	61.9	
8+8 Core 65W	202 OC	N/A	N/A	65	0	71.3	
8+4 Core 65W		N/A	N/A	65	0	71.3	
6+0 -Core 65W		N/A	N/A	65	0	71.3 Note 9	
4+0 Core 65W		N/A	N/A	65	0	71.3 Note 9	
4+0 Core 60W		N/A	N/A	60	0	68.9	
4+0 Core 58W		N/A	N/A	58	0	68.9	
2+0 -Core 46W		N/A	N/A	46	0	62.2	
8+8 Core 35W		202 OD	N/A	N/A	35	0	65.5
8+4 Core 35W			N/A	N/A	35	0	65.5



Processor IA Cores, Graphics Configuration and Processor Base Power (a.k.a TDP)	PCG7	Maximum Power Package C7 (W) ^{1,4,5}	Maximum Power Package C8 (W) ^{1,4,5}	TTV Processor Base Power (a.k.a TDP) (W) ^{6,7}	Min TCASE (°C)	Maximum TTV TCASE (°C)
6+0 -Core 35W		N/A	N/A	35	0	65.5
4+0 -Core 35W		N/A	N/A	35	0	65.5
2+0 -Core 35W		N/A	N/A	35	0	65.5

Notes:

1. The package C-state power is the worst case power in the system configured as follows:
 - a. Memory configured for DDR4 and populated with two DIMMs per channel.
 - b. DMI and PCIe links are at L1
2. Specification at DTS = 50 °C and minimum voltage loadline.
3. Specification at DTS = 35 °C and minimum voltage loadline.
4. These DTS values in Notes 2 - 3 are based on the TCC Activation MSR having a value of 100, Refer [Thermal Management Features](#).
5. These values are specified at VCC_MAX and VNOM for all other voltage rails for all processor frequencies. Systems should be designed to ensure the processor is not to be subjected to any static VCC and ICC combination wherein VCCP exceeds VCCP_MAX at specified ICCP. Refer the loadline specifications.
6. Thermal Processor Base Power (a.k.a TDP) should be used for processor thermal solution design targets. Processor Base Power is not the maximum power that the processor can dissipate. Processor Base Power (a.k.a TDP) is measured at DTS = -
 1. Processor Base Power(a.k.a TDP) is achieved with the Memory configured for DDR
7. Platform Compatibility Guide (PCG) (previously known as FMB) provides a design target for meeting all planned processor frequency requirements.
8. Not 100% tested. Specified by design characterization.

TCONTROL Offset Configuration (S-Processor Line - Client)

	8+8 SegmentCore	8+8 Core	8+8 Core	8+8 Core	8+4 Core	6+4 Core	6+0 Core		4+0			2+0 Core	
Processor Base Power (a.k. a TDP) [W]	150	125	65	35	125	125	65	35	60	58	35	46	35
TEMP_ TARGET (TC ONT ROL) [°C]	20	20	20	20	20	20	20	20	20	20	20	20	20

Notes:

- Digital Thermal Sensor (DTS) based fan speed control is recommended to achieve optimal thermal performance.
- Intel recommends full cooling capability at approximately the DTS value of -1, to minimize TCC activation risk.
- For example, if TCONTROL = 20 °C, Fan acceleration operation will start at 80 °C (100 °C - 20 °C).

Thermal Profile for PCG 2020 Processor

Thermal Profile for PCG 2022E Processor

Thermal Profile for PCG 2022E Processor

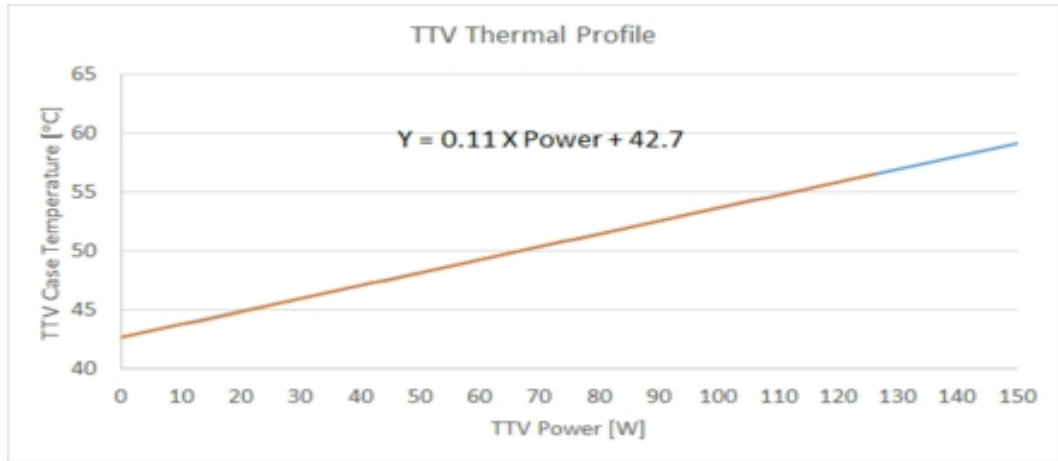

Note: Refer to the following table for discrete points that constitute the thermal profile.

Thermal Test Vehicle Thermal Profile for PCG 2022E Processor

Power (W)	T _{CASE_MAX} (°C)	Power (W)	T _{CASE_MAX} (°C)
0	42.7	76	51.06
2	42.92	78	51.28
4	43.14	80	51.5
6	43.36	82	51.72
8	43.58	84	51.94
10	43.8	86	52.16
12	44.02	88	52.38
14	44.24	90	52.6
16	44.46	92	52.82
18	44.68	94	53.04
20	44.9	96	53.26
22	45.12	98	53.48

Power (W)	T _{CASE_MAX} (°C)		Power (W)	T _{CASE_MAX} (°C)
24	45.34		100	53.7
26	45.56		102	53.92
28	45.78		104	54.14
30	46		106	54.36
32	46.22		108	54.58
34	46.44		110	54.8
36	46.66		112	55.02
38	46.88		114	55.24
40	47.1		116	55.46
42	47.32		118	55.68
44	47.54		120	55.9
46	47.76		122	56.12
48	47.98		124	56.34
50	48.2		126	56.56
52	48.42		128	56.78
54	48.64		130	57
56	48.86		132	57.22
58	49.08		134	57.44
60	49.3		136	57.66
62	49.52		138	57.88
64	49.74		140	58.1
66	49.96		142	58.32
68	50.18		144	58.54



Power (W)	T _{CASE_MAX} (°C)		Power (W)	T _{CASE_MAX} (°C)
70	50.4		146	58.76
72	50.62		148	58.98
74	50.84		150	59.2

Thermal Profile for PCG 2020A Processor

Thermal Profile for PCG 2020A Processor

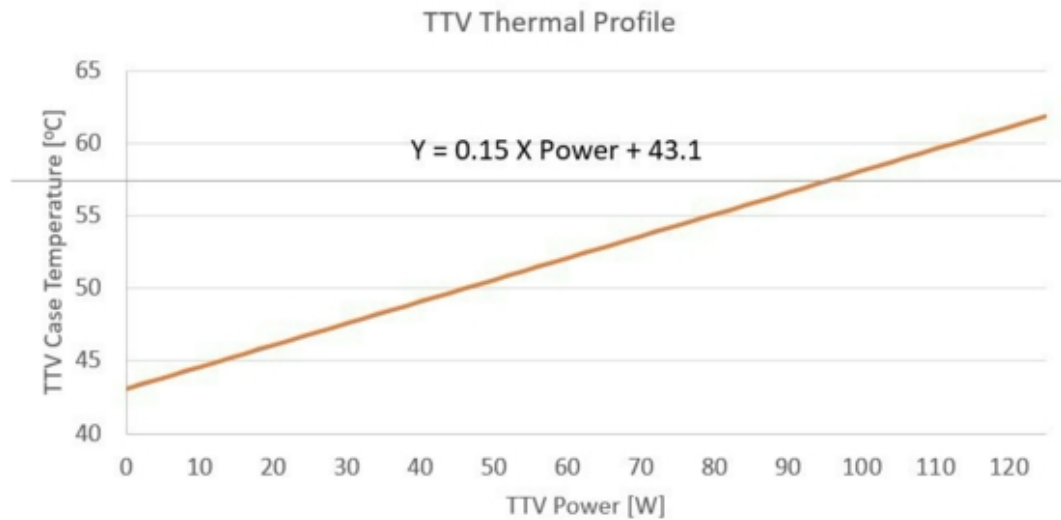

Note: Refer to the following table for discrete points that constitute the thermal profile.

Thermal Test Vehicle Thermal Profile for PCG 2020A Processor

Power (W)	T _{CASE_MAX} (°C)		Power (W)	T _{CASE_MAX} (°C)
0	43.1		64	52.7
2	43.4		66	53
4	43.7		68	53.3

Power (W)	T _{CASE_MAX} (°C)		Power (W)	T _{CASE_MAX} (°C)
6	44.0		70	53.6
8	44.3		72	53.9
10	44.6		74	54.2
12	44.9		76	54.5
14	45.2		78	54.8
16	45.5		80	55.1
18	45.8		82	55.4
20	46.1		84	55.7
22	46.4		86	56.0
24	46.7		88	56.3
26	47.0		90	56.6
28	47.3		92	56.9
30	47.6		94	57.2
32	47.9		96	57.5
34	48.2		98	57.8

Power (W)	T _{CASE_MAX} (°C)		Power (W)	T _{CASE_MAX} (°C)
36	48.5		100	58.1
38	48.8		102	58.4
40	49.1		104	58.7
42	49.4		106	58.0
44	49.7		108	58.3
46	50.0		110	59.6
48	50.3		112	59.9
50	50.6		114	60.2
52	50.9		116	60.5
54	51.2		118	60.8
56	51.5		120	61.1
58	51.8		122	61.4
60	52.1		124	61.7
62	52.4		125	61.85

Thermal Profile for PCG 2020C Processor

Thermal Profile for PCG 2020C Processor

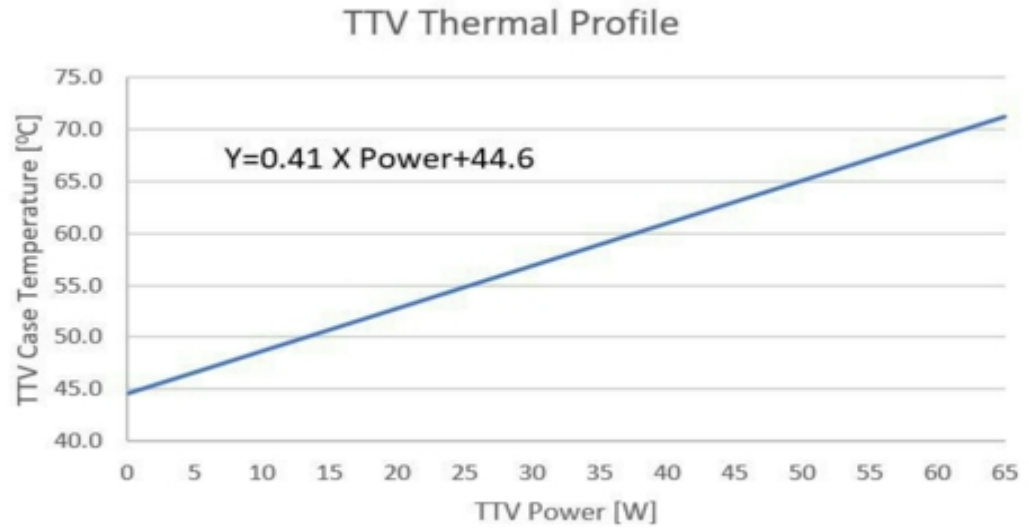

Note: Refer to table below for discrete points that constitute the thermal profile.

Thermal Test Vehicle Thermal Profile for PCG 2020C Processor

Power (W)	T _{CASE_MAX} (°C)		Power (W)	T _{CASE_MAX} (°C)
0	44.6		34	58.54
2	45.42		36	59.36
4	46.24		38	60.18
6	47.06		40	61.0
8	47.88		42	61.82
10	48.7		44	62.64

Power (W)	T _{CASE_MAX} (°C)		Power (W)	T _{CASE_MAX} (°C)
12	49.52		46	63.46
14	50.34		48	64.28
16	51.16		50	65.1
18	51.98		52	65.92
20	52.8		54	66.74
22	53.62		56	67.56
24	54.42		58	68.38
26	55.26		60	69.2
28	56.08		62	70.02
30	56.9		64	70.84
32	57.72		65	71.25

Thermal Profile for PCG 2020D Processor

Thermal Profile for PCG 2020D Processor

Thermal Test Vehicle Thermal Profile for PCG 2020D Processor

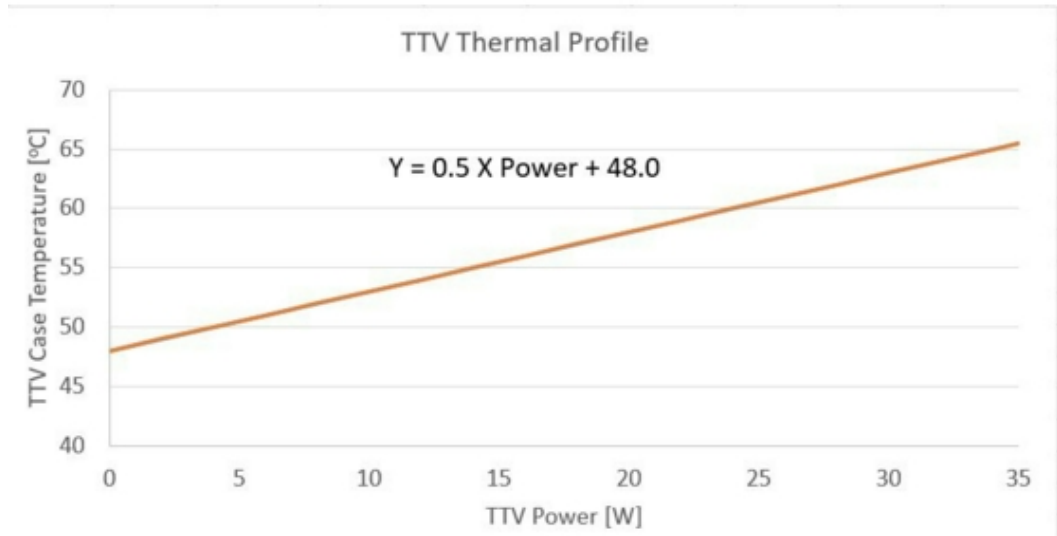

Note: Refer to table below for discrete points that constitute the thermal profile.

Thermal Test Vehicle Thermal Profile for PCG 2020D Processor

Power (W)	T _{CASE_MAX} (°C)	Power (W)	T _{CASE_MAX} (°C)
0	48.0	20	58.0
2	49.0	22	59.0
4	50.0	24	60.0
6	51.0	26	61.0
8	52.0	28	62.0
10	53.0	30	63.0
12	54.0	32	64.0

Power (W)	T _{CASE_MAX} (°C)		Power (W)	T _{CASE_MAX} (°C)
14	55.0		34	65.0
16	56.0		35	65.5
18	57.0			

Thermal Metrology

The maximum TTV case temperatures (T_{CASE-MAX}) can be derived from the data in the appropriate TTV thermal profile earlier in this chapter. The TTV T_{CASE} is measured at the geometric top center of the TTV integrated heat spreader (IHS). Below figure illustrates the location where T_{CASE} temperature measurements should be made.

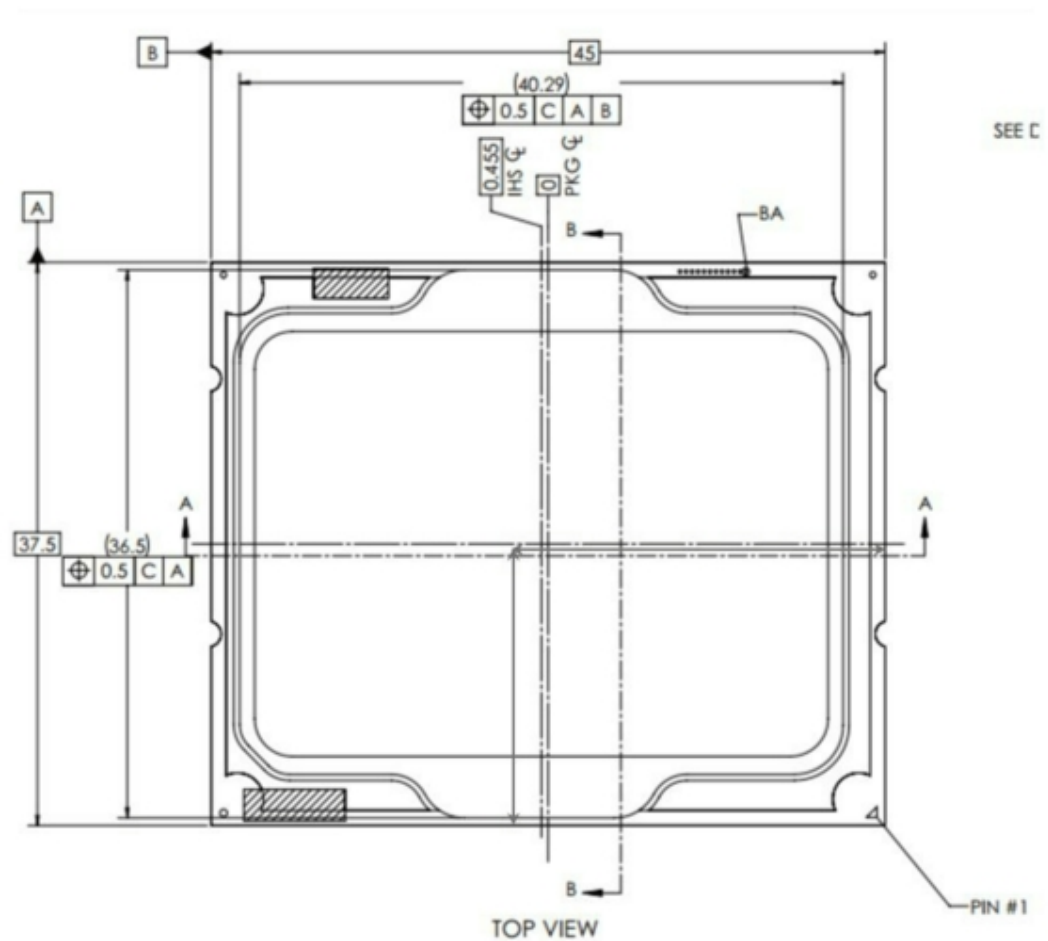
Thermal Test Vehicle (TTV) Case Temperature (T_{CASE}) Measurement Location

The following supplier can machine the groove and attach a thermocouple to the IHS. The following supplier is listed as a convenience to Intel's general customers and may be subject to change without notice. THERM-X OF CALIFORNIA, 3200 Investment Blvd, Hayward, Ca 94544. George Landis +1-510-441-7566 Ext. 368 george@therm-x.com. The vendor part number is XTMS1565.

Fan Speed Control Scheme with DTS

With Digital Thermal Sensor (DTS) 1.1

To correctly use DTS 1.1, the designer must first select a worst case scenario $T_{AMBIENT}$, and ensure that the Fan Speed Control (FSC) can provide a Ψ_{CA} that is equivalent or greater than the Ψ_{CA} specification.

The DTS 1.1 implementation consists of two points:

- a Ψ_{CA} at $T_{CONTROL}$

- a Ψ_{CA} at DTS = -1
- The Ψ_{CA} point at DTS = -1 defines the minimum Ψ_{CA} required at Processor Base Power (a.k.a TDP) considering the worst case system design $T_{AMBIENT}$ design point:

$$\Psi_{CA} = (T_{CASE-MAX} - T_{AMBIENT-TARGET} - 1) / TDP$$

For example, for a 125 W Processor Base Power (a.k.a TDP) part, the T_{CASE} maximum is 62.0 °C and at a worst case design point of 40 °C local ambient this will result in:

$$\Psi_{CA} = (62.0 - 40 - 1) / 125 = 0.168 \text{ } ^\circ\text{C/W}$$

Similarly for a system with a design target of 45 °C ambient, the Ψ_{CA} at DTS = -1 needed will be 0.128 °C/W.
- The second point defines the thermal solution performance (Ψ_{CA}) at $T_{CONTROL}$. The following table lists the required Ψ_{CA} for the various Processor Base Power (a.k.a TDP) processors.

These two points define the operational limits for the processor for DTS 1.1 implementation. At $T_{CONTROL}$ the fan speed must be programmed such that the resulting Ψ_{CA} is better than or equivalent to the required Ψ_{CA} listed in the following table. Similarly, the fan speed should be set at DTS = -1 such that the thermal solution performance is better than or equivalent to the Ψ_{CA} requirements at $T_{AMBIENT-MAX}$.

The fan speed controller must linearly ramp the fan speed from processor DTS = $T_{CONTROL}$ to processor DTS = -1.

Digital Thermal Sensor (DTS) 1.1 Definition Points

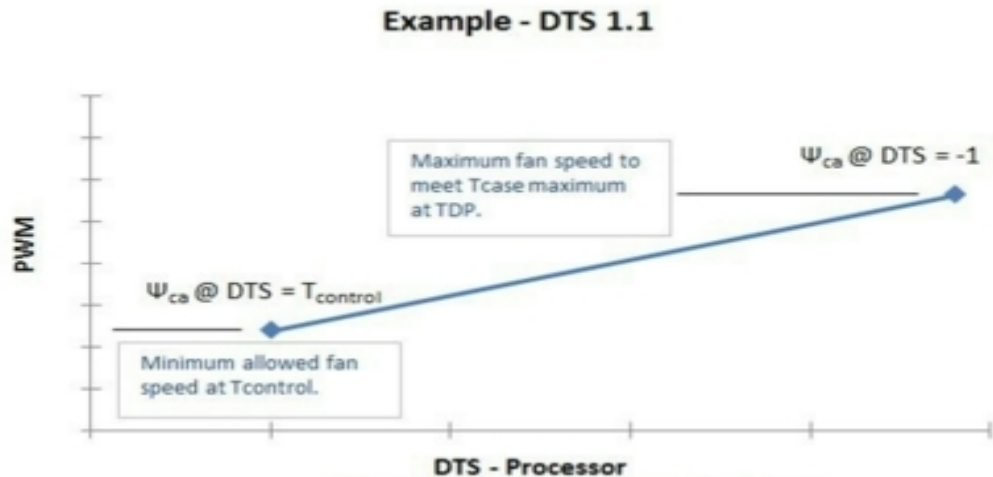

Digital Thermal Sensor (DTS) 1.1 Thermal Solution Performance Above $T_{CONTROL}$

	Ψ_{CA} at DTS = $T_{CONTROL}$ ^{1,2}	Ψ_{CA} at DTS = -1	Ψ_{CA} at DTS = -1	Ψ_{CA} at DTS = -1
	At System $T_{AMBIENT_MAX}$	At System $T_{AMBIENT_MAX}$	At System $T_{AMBIENT_MAX}$	At System $T_{AMBIENT_MAX}$
Processor	= 30 °C	= 40 °C	= 45 °C	= 50 °C

Processor		Ψ_{CA} at DTS = $T_{CONTROL}^{1,2}$ At System $T_{AMBIENT_MAX}$ = 30 °C	Ψ_{CA} at DTS = -1 At System $T_{AMBIENT_MAX}$ = 40 °C	Ψ_{CA} at DTS = -1 At System $T_{AMBIENT_MAX}$ = 45 °C	Ψ_{CA} at DTS = -1 At System $T_{AMBIENT_MAX}$ = 50 °C
8+8 -Core	150W	0.21	0.12	0.08	0.05
8+8 -Core	125W	0.26	0.16	0.12	0.08
8+4-Core	125W	0.28	0.16	0.12	0.08
6+4 -Core	125W	0.30	0.16	0.12	0.08
8+8-Core	65W	0.64	0.46	0.38	0.31
8+4-Core	65W	0.65	0.46	0.38	0.31
8+8-Core	35W	0.86	0.7	0.55	0.41
6+0-Core	65W	0.72	0.46	0.38	0.31
6+0-Core	35W	0.97	0.7	0.55	0.41
4+0-Core	35W	1.0	0.7	0.55	0.41
4+0-Core	60W	0.77	0.7	0.55	0.41
4+0-Core	58W	0.78	0.7	0.55	0.41
2+0-Core	35W	0.1.18	0.7	0.55	0.41



Processor		Ψ_{CA} at DTS = $T_{CONTROL}^{1,2}$ At System $T_{AMBIENT_MAX}$ = 30 °C	Ψ_{CA} at DTS = -1 At System $T_{AMBIENT_MAX}$ = 40 °C	Ψ_{CA} at DTS = -1 At System $T_{AMBIENT_MAX}$ = 45 °C	Ψ_{CA} at DTS = -1 At System $T_{AMBIENT_MAX}$ = 50 °C
2+0-Core	46W	0.84	0.7	0.55	0.41

Notes:

- Ψ_{CA} at “DTS = $T_{CONTROL}$ ” is applicable to systems that have an internal T_{RISE} (T_{ROOM} temperature to Processor cooling fan inlet) of less than 10 °C. In case the expected T_{RISE} is greater than 10 °C, a correction factor should be used as explained below. For each 1 °C T_{RISE} above 10 °C, the correction factor (CF) is defined as $CF = 1.7 / (\text{Processor Base Power (a.k.a TDP)})$.
- The table data match for GT0.

With Digital Thermal Sensor (DTS) 2.0

To simplify processor thermal specification compliance, the processor calculates the DTS Thermal Profile from $T_{CONTROL}$ Offset, TCC Activation Temperature, Processor Base Power (a.k.a TDP), and the Thermal Margin Slope provided in the following table.

Note: TCC Activation Offset is 0 for the processors.

Using the DTS Thermal Profile, the processor can calculate and report the Thermal Margin, where a value less than 0 indicates that the processor needs additional cooling, and a value greater than 0 indicates that the processor is sufficiently cooled.

Digital Thermal Sensor (DTS) 2.0 Definition Points

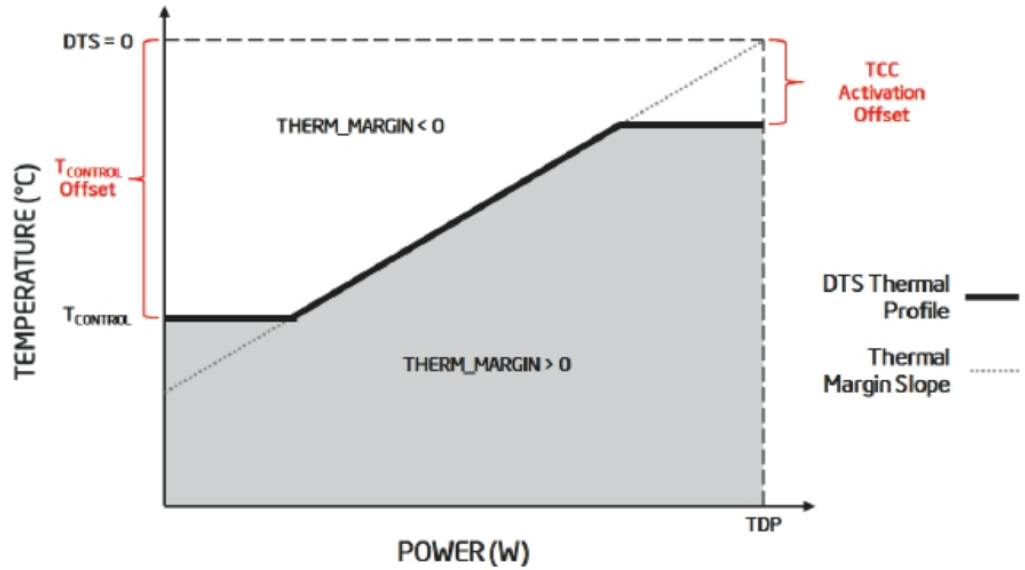

Thermal Margin Slope

PCG	Die Configuration (Cores/GT)	Processor Base Power (a.k.a TDP) [W]	TCC Activation [°C]	Temperature Control Offset	Thermal Margin Slope [°C/W]
2020A	8+8 Core	150	90 ¹	20	0.32
2020A	8+8 Core	125	100	20	0.35
2020A	8+8 Core GT0	125	100	20	0.36
2020A	8+4 Core	125	100	20	0.38
2020A	8+4 Core GT0	125	100	20	0.39
2020A	6+4 Core	125	100	20	0.44

PCG	Die Configuration (Cores/GT)	Processor Base Power (a.k.a TDP) [W]	TCC Activation [°C]	Temperature Control Offset	Thermal Margin Slope [°C/W]
2020A	6+4 Core GT0	125	100	20	0.45
2020C	8+8 Core	65	100	20	0.59
2020C	8+4 Core	65	100	20	0.61
2020C	6+0 Core	65	100	20	0.77
2020C	4+0 Core	60	100	20	0.92
2020C	4+0 Core	58	100	20	0.96
2020C	2+0 Core	46	100	20	1.24
2020D	8+8 Core	35	100	20	0.68
2020D	6+0 Core	35	100	20	0.84
2020D	4+0 Core	35	100	20	0.95
2020D	2+0 Core	35	100	20	1.26

Notes:

- The default BIOS settings for this SKU is 10C TCC offset.

Memory

System Memory Interface

Processor SKU Support Matrix

DDR Support Matrix Table

Technology	DDR4		DDR5		LPDDR4x	LPDDR5/x 15,16
Processor	HX / S / H / P / U15	HX / S	HX / S / H / P / U15	HX / S	H/P/U1 5/U9	H/P/U15/ U9
Configuration	1DPC	2DPC ₁₁	1DPC	2DPC ₁₁	1R/2R	1R/2R
Maximum Frequency [MT/s]	S UDIMM 3200 HX / S / H / P / U15 SoDIMM 3200	S UDIMM 3200 ₁₂ HX SoDIMM : 1 DIMM - 2933 ₁₂ 2 DIMMs - 3200	HX / S / P / U15 SoDIMM 4800 S : UDIMM 4800	S UDIMM : 1 DIMM - 4400, 2 DIMMs 1R - 4000, 2 DIMMs 2R - 3600 HX SoDIMM: 1 DIMM - 4000, 2 DIMMs 1R - 4000, 2 DIMMs 2R - 3600	4266	Type4 : 1R/2R :5200 P/H Type3: 1R/2R 4800
VDDQ [V] ₆	1.2		5,1.1 ¹⁰		0.6	0.5
VDD2 [V] ₆	1.2		1.1		1.1	1.05

Technology	DDR4		DDR5		LPDDR4x	LPDDR5/x 15,16
	2	4	2	4		
Maximum RPC ₂	2	4	2	4	2	2
Die Density [Gb]	8,16	8,16	16		8,16	8, 12 ₇ , 16
Ballmap Mode ₁₁	IL /NIL	IL /NIL	P : NIL, HX /S - IL	NIL	NIL	NIL

Notes:

- 1DPC refer to when only 1DIMM slot per channel is routed.
- RPC = Rank Per Channel
- An Interleave SoDIMM/MD placements like butterfly or back-to-back supported with a Non-Interleave ballmap mode at H, P, U15 - Processor Line
- Memory down of all technologies should be implemented homogeneous means that all DRAM devices should be from the same vendor and have the same part number. Implementing a mix of DRAM devices may cause serious signal integrity and functional issues.
- There is no support for memory modules with different technologies or capacities on opposite sides of the same memory module. If one side of a memory module is populated, the other side is either identical or empty.
- VDD2 is Processor and DRAM voltage, and VDDQ is DRAM voltage.
- Pending DRAM samples availability.
- Maximum 2DPC frequency supported when same DIMM part number populated Within channel. Frequency is not guaranteed when mix DIMM's populated.
- Mix DIMM in 2DPC use 2N Command Mode, speed to be set in BIOS per margin check.
- 5V is SODIMM/UDIMM voltage, 1.1V is Memory down voltage.
- DDR4/DDR5 SoDIMM 2DPC - Not supported on S -Processor Line.
- Far memory slot to be populated in case single dimm placed on 2DPC channel
- IL/NIL mode depends on Memory topology.
- DDR4/DDR5 ECC is supported only when all memory populated in the system supports ECC.
- LPDDR5 technology supports 8 Bank Mode, BG (Bank Group) Mode and 16 Bank Mode. This processor supports 8 Bank Mode only.
- LPDDR5x 1a node Supported from MR5 BKC release under LPDDR5 POR speed and with 8B mode only.

DDR Technology Support Matrix

Technology	Form Factor	Ball Count	Processor
DDR4	UDIMM	288	S
DDR4	SoDIMM	260	HX/H/P/U15/S
DDR4	x16 SDP (1R) ¹	96	H/P/U15
DDR4	x16 DDP (1R) ¹	96	H/P/U15
DDR4	x8 SDP (1R) ¹	78	H/P/U15
DDR5	SoDIMM	262	HX/H/P/U15/S
DDR5	UDIMM	288	S
DDR5	x8 SDP (1R) ¹	78	H/P/U15
DDR5	x16 SDP (1R) ¹	102	H/P/U15
LPDDR4x	x32 (1R, 2R) ¹	200	H/P/U15/U9
LPDDR4x	x64 (1R, 2R) ¹	432	H/P/U15/U9
LPDDR4x	x64 (1R, 2R) ¹	556	U9
LPDDR5/x	x64 (1R, 2R) ¹	496	H/P/U15/U9

Technology	Form Factor	Ball Count	Processor
LPDDR5/x	x32 (1R, 2R) ¹	315	H/P/U15/U9

Notes:

- Memory down of all technologies should be implemented homogeneously, which means that all DRAM devices should be from the same vendor and have the same part number. Implementing a mix of DRAM devices may cause serious signal integrity and functional issues, DDR4/DDR5 restriction is for single MC configuration, LPDDR4x/LPDDR5/x restriction is for both MC configuration (all DRAMs in the system must be from same Part Number).

Supported Memory Modules and Devices

Supported DDR4 Non-ECC SoDIMM Module Configurations (S/H/P/U15-Processor Line)

Raw Card Version	DIMM Capacity	DRAM Device Technology	DRAM Organization	# of DRAM Devices	# of Ranks	# of Row/Col Address Bits	# of Banks Inside DRAM	Page Size
A	8 GB	8 Gb	1024M x 8	8	1	16/10	16	8K
A	16 GB	16 Gb	2048M x 8	8	1	17/10	16	8K
C	4 GB	8 Gb	512M x 16	4	1	16/10	8	8K
C	8 GB	16 Gb	1024M x 16	4	1	17/10	8	8K
E	16 GB	8 Gb	1024M x 8	16	2	16/10	16	8K
E	32 GB	16 Gb	2048M x 8	16	2	17/10	16	8K

Supported DDR4 ECC SoDIMM Module Configurations (S-Processor Line)

Raw Card Version	DIMM Capacity	DRAM Device Technology	DRAM Organization	# of DRAM Devices	# of Ranks	# of Row/Col Address Bits	# of Banks Inside DRAM	Page Size
D	8 GB	8 Gb	1024M x 8	9	1	16/10	16	8K
D	16 GB	16 Gb	2048M x 8	9	1	17/10	16	8K
G	8 GB	8 Gb	1024M x 8	18	2	16/10	16	8K
G	16 GB	16 Gb	2048M x 8	18	2	17/10	16	8K
F	16 GB	8 Gb	1024M x 8	18	2	16/10	16	8K
F	32 GB	16 Gb	2048M x 8	18	2	17/10	16	8K

Supported DDR4 Non-ECC UDIMM Module Configurations (S-Processor Line)

Raw Card Version	DIMM Capacity	DRAM Device Technology	DRAM Organization	# of DRAM Devices	# of Ranks	# of Row/Col Address Bits	# of Banks Inside DRAM	Page Size
A	8 GB	8 Gb	1024M x 8	8	1	16/10	16	8K
A	16 GB	16 Gb	2048M x 8	8	1	17/10	16	8K
C	4 GB	8 Gb	512M x 16	4	1	16/10	8	8K

Raw Card Version	DIMM Capacity	DRAM Device Technology	DRAM Organization	# of DRAM Devices	# of Ranks	# of Row/Col Address Bits	# of Banks Inside DRAM	Page Size
C	8 GB	16 Gb	1024M x 16	4	1	17/10	8	8K
B	16 GB	8 Gb	1024M x 8	16	2	16/10	16	8K
B	32 GB	16 Gb	2048M x 8	16	2	17/10	16	8K

Supported DDR4 ECC UDIMM Module Configurations (S-Processor Line)

Raw Card Version	DIMM Capacity	DRAM Device Technology	DRAM Organization	# of DRAM Devices	# of Ranks	# of Row/Col Address Bits	# of Banks Inside DRAM	Page Size
D	8 GB	8 Gb	1024M x 8	9	1	16/10	16	8K
D	16 GB	16 Gb	2048M x 8	9	1	17/10	16	8K
E	16 GB	8 Gb	1024M x 8	18	2	16/10	16	8K
E	32 GB	16 Gb	2048M x 8	18	2	17/10	16	8K

Supported DDR5 Non-ECC SoDIMM Module Configurations (S/H/P/U15-Processor Line)

Raw Card Version	DIMM Capacity	DRAM Device Technology	DRAM Organization	# of DRAM Devices	# of Ranks	# of Row/Col Address Bits	# of Banks Inside DRAM	Page Size
A	16 GB	16 Gb	2048M x 8	8	1	17/10	16	8K

Raw Card Version	DIMM Capacity	DRAM Device Technology	DRAM Organization	# of DRAM Devices	# of Ranks	# of Row/Col Address Bits	# of Banks Inside DRAM	Page Size
C	8 GB	16 Gb	1024M x 16	4	1	17/10	8	8K
B	32 GB	16 Gb	2048M x 8	16	2	17/10	16	8K

Supported DDR5 ECC SoDIMM Module Configurations (S-Processor Line)

Raw Card Version	DIMM Capacity	DRAM Device Technology	DRAM Organization	# of DRAM Devices	# of Ranks	# of Row/Col Address Bits	# of Banks Inside DRAM	Page Size
D	16 GB	16 Gb	2048M x 8	9	1	17/10	16	8K
E	32 GB	16 Gb	2048M x 8	18	2	17/10	16	8K

Supported DDR5 Non-ECC UDIMM Module Configurations (S-Processor Line)

Raw Card Version	DIMM Capacity	DRAM Device Technology	DRAM Organization	# of DRAM Devices	# of Ranks	# of Row/Col Address Bits	# of Banks Inside DRAM	Page Size
A	16 GB	16 Gb	2048M x 8	8	1	17/10	16	8K
C	8 GB	16 Gb	1024M x 16	4	1	17/10	8	8K
B	32 GB	16 Gb	2048M x 8	16	2	17/10	16	8K



Supported DDR5 ECC UDIMM Module Configurations (S-Processor Line)

Raw Card Version	DIMM Capacity	DRAM Device Technology	DRAM Organization	# of DRAM Devices	# of Ranks	# of Row/Col Address Bits	# of Banks Inside DRAM	Page Size
D	16 GB	16 Gb	2048M x 8	9	1	17/10	16	8K
E	32 GB	16 Gb	2048M x 8	18	2	17/10	16	8K

Supported DDR4 Memory Down Device Configurations (H/P /U15 Processor Line)

Maximum System Capacity ³	PKG Type (Die bits / Package bits)	DRAM Organization / Package Type	Package Density	Die Density	Dies Per Channel	Rank Per Channel	PKGs Per Channel	Physical Device Rank	Banks Inside DRAM	Page Size
32 GB	SDP 8x8	1024 M x 8	8 Gb	8 Gb	16	2	16	1	16	8K
64 GB	SDP 8x8	2048 M x 8	16 Gb	16 Gb	16	2	16	1	16	8K
8 GB	SDP 16x16	512M x 16	8 Gb	8 Gb	4	1	4	1	8	8K
16 GB ¹	SDP 16x16	1024 M x 16	16 Gb	16 Gb	4	1	4	1	8	8K
16 GB	DDP 8x16	1024 M x 16	16 Gb	8 Gb	8	1	4	1	16	8K

Maximum System Capacity ³	PKG Type (Die bits / Package bits)	DRAM Organization / Package Type	Package Density	Die Density	Dies Per Channel	Rank Per Channel	PKGs Per Channel	Physical Device Rank	Banks Inside DRAM	Page Size
32 GB ²	DDP 8x16	2048 M x 16	32 Gb	16 Gb	8	1	4	1	16	8K

Notes:

1. For SDP: 1Rx16 using 16 GB die density - the maximum system capacity is 16 GB
2. For DDP: 1Rx16 using 16 GB die density - the maximum system capacity is 32 GB.
3. Maximum system capacity refer to system with 2 channels populated

Supported DDR5 Memory Down Device Configurations (H/P/U15 Processor Line)

Maximum System Capacity	PKG Type (Die bits / Package bits)	DRAM Organization / Package Type	Package Density	Die Density	Dies Per Channel	Rank Per Channel	PKGs Per Channel	Physical Device Rank	Banks Inside DRAM	Page Size
32 GB	SDP 8x8	2048M x 8	16 Gb	16 Gb	8	1	8	1	16	8K
16 GB ¹	SDP 16x16	1024M x 16	16 Gb	16 Gb	4	1	4	1	8	8K

Notes:

1. For SDP: 1Rx16 using 16 GB die density - the maximum system capacity is 16 GB
2. Maximum system capacity, refer to system with 2 channels populated

Supported LPDDR4x x32 DRAMs Configurations (H/P/U Processor Line)

Maximum System Capacity ⁴	PKG Type	(Die bits per Ch x PKG bits) ²	Die Density	PKG Density	Rank Per PKGs
8 GB	DDP	16x32	8 Gb	16 Gb	1
16 GB	QDP	16x32	8 Gb	32 Gb	2
32 GB	ODP	16x32(Byte mode)	8 Gb	64 Gb	2
16 GB	QDP	16x32	16 Gb	32 Gb	1
32 GB	ODP	16x32	16 Gb	64 Gb	2

Notes:

1. x32 BGA devices are 200 balls
2. QDP = Quad Die Package, ODP-Octal Die Package
3. Each LPDDR4x channel include two sub-channels
4. Maximum system capacity refers to system with all 8 sub channels populated

Supported LPDDR4x x64 DRAMs Configurations (H/P/U Processor Line)

Maximum System Capacity ³	PKG Type	(Die bits per Ch x PKG bits)	Die Density	Ball Count Per PKG	PKG Density	DRAM Channels Per PKGs	Processor Line	Rank Per PKGs
8 GB	QDP	16x64	8 Gb	432	32 Gb	4	H/P/U	1
16 GB	ODP	16x64	8 Gb	432	64 Gb	4	H/P/U	2

Maximum System Capacity ³	PKG Type	(Die bits per Ch x PKG bits)	Die Density	Ball Count Per PKG	PKG Density	DRAM Channels Per PKGs	Processor Per Line	Rank Per PKGs
16 GB	QDP	16x64	16 Gb	432	64 Gb	4	H/P/U	2
8 GB	QDP	16x64	8 Gb	556	32 Gb	4	U9	1
16 GB	ODP	16x64	8 Gb	556	64 Gb	4	U9	2
16 GB	QDP	16x64	16 Gb	556	64 Gb	4	U9	2

Notes:

1. QDP = Quad Die Package, ODP-Octal Die Package
2. Each LPDDR4x channel include two sub-channels
3. Maximum system capacity refers to system with all 8 sub-channels populated

Supported LPDDR5/x x32 DRAMs Configurations⁶ (H/P/U Processor Line)

Maximum System Capacity ⁴	PKG Type	(Die bits per Ch x PKG bits) ²	Die Density	PKG Density	Rank Per PKGs
12 GB ⁵	DDP	16x32	12 Gb	24 Gb	1
24 GB ⁵	QDP	16x32	12 Gb	48 Gb	2
16 GB	DDP	16x32	16 Gb	32 Gb	1
32 GB	QDP	16x32	16 Gb	64 Gb	2

Maximum System Capacity ⁴	PKG Type	(Die bits per Ch x PKG bits) ²	Die Density	PKG Density	Rank Per PKGs
64 GB ⁵	ODP	16x32	16 Gb	128 Gb	2
8 GB	DDP	16x32	8 Gb	16 Gb	1
16 GB	QDP	16x32	8 Gb	32 Gb	2
32 GB	ODP	16x32	8 Gb	64 Gb	2

Notes:

1. x32 BGA devices are 315 balls
2. QDP = Quad Die Package, ODP-Octal Die Package
3. Each LPDDR5 channel include two sub-channels
4. Maximum system capacity refers to system with all 8 sub channels populated
5. Pending DRAM samples availability.
6. LPDDR5x supported with 1a node only.

Supported LPDDR5/x x64 DRAMs Configurations ⁴(H/P/U Processor Line)

Maximum System Capacity ³	PKG Type	(Die bits per Ch x PKG bits)	Die Density	PKG Density	DRAM Channels Per PKGs	Rank Per PKGs
16 GB	QDP	16x64	16 Gb	64 Gb	4	1
32 GB	ODP	16x64	16 Gb	128 Gb	4	2

Maximum System Capacity ³	PKG Type	(Die bits per Ch x PKG bits)	Die Density	PKG Density	DRAM Channels Per PKGs	Rank Per PKGs
8 GB	QDP	16x64	8 Gb	32 Gb	4	1
16 GB	ODP	16x64	8 Gb	64 Gb	4	2

Notes:

1. QDP = Quad Die Package, ODP-Octal Die Package
2. Each LPDDR5 channel include two sub-channels
3. Maximum system capacity refers to system with all 8 sub-channels populated
4. LPDDR5x supported with 1a node only.

System Memory Timing Support

The IMC supports the following DDR Speed Bin, CAS Write Latency (CWL), and command signal mode timings on the main memory interface:

- tCL = CAS Latency
- tRCD = Activate Command to READ or WRITE Command delay
- tRP = PRECHARGE Command Period
- tRPb = per-bank PRECHARGE time
- tRPab = all-bank PRECHARGE time
- CWL = CAS Write Latency
- Command Signal modes:
 - 2N indicates a new DDR5/DDR4/LPDDR4x/LPDDR5/x command may be issued every 2 clocks.
 - 1N indicates a new DDR5/DDR4/LPDDR4x/LPDDR5/x command may be issued every clock.

System Memory Timing Support

DDR System Memory Timing Support

DRAM Device	Transfer Rate (MT/s)	tCL (tCK)	tRCD (ns)	tRP (ns)	CWL (tCK)	DPC	CMD Mode
DDR4	3200	22	13.75	13.75	9-12, 14,16,18, 20	1,2	2N
DDR5	4000	36	17	17.00	34	1	2N
	4400	40	16.82	16.82	38	1,2 ¹	2N
	4800	40	16.67	16.67	38	1	2N

Note:

1. 2 DPC supported when one slot is populated in each channel
2. Support 8 Bank Mode (8B) only

LPDDR System Memory Timing Support

DRAM Device	Transfer Rate (MT/s)	tCL (tCK)	tRCD (ns)	tRPpb (ns)	tRPab (ns)	WL (tCK) Set B
LPDDR4x	4266	36	18	18	21	34
LPDDR5/x	4800	13	18.33	18.33	21.67	12
	5200	15	18.46	18.46	21.54	14

Note:

1. Support 8 Bank Mode (8B) only

SAGV Points

SAGV (System Agent Geyserville) is a way by which they SoC can dynamically scale the work point (V/F), by applying DVFS (Dynamic Voltage Frequency Scaling) based on memory

bandwidth utilization and/or the latency requirement of the various workloads for better energy efficiency at System-Agent. Pcode heuristics are in charge of providing request for Qclock work points by periodically evaluating the utilization of the memory and IA stalls.

SA Speed Enhanced Speed Steps (SA-GV) and Gear Mode Frequencies

	Technology	DDR Maximum Rate [MT/s]	SAGV-LowBW	SAGV-MedBW	SAGV-HighBW	SAGV-MaxBW/lowest latency
S/HX-Processors	DDR4	3200	2133 G2	2666 G1	2933 G1	3200 G1
	DDR5 1DPC	4800	2000 G2	3600 G2	4400 G2	4800 G2
	DDR5 1DPC on 2DPC SODIMM	4000	2000 G2	3600 G2	3600 G2	4000 G2
	DDR5 1DPC on 2DPC UDIMM (S only)	4400	2000 G2	3600 G2	4000 G2	4400 G2
	DDR5 2DPC 1R/1R	4000	2000 G2	3600 G2	3600 G2	4000 G2
	DDR5 2DPC 2R/2R	3600	2000 G2	3200 G2	3200 G2	3600 G2
H-Processor	LPDDR4x	4266	2666 G4	3733 G4	4266 G4	4266 G2
	LPDDR5/x 1R/2R ³	5200	2400 G4	4800 G4	5200 G4	5200 G2
	LPDDR5/x 1R/2R	4800	2400 G4	4400 G4	4400 G4	4800 G2
	DDR4	3200	2133 G2	2933 G2	3200 G2	2666 G1
	DDR5	4800	2000 G2	3600 G2	4400 G2	4800 G2

	Technology	DDR Maximum Rate [MT/s]	SAGV-LowBW	SAGV-MedBW	SAGV-HighBW	SAGV-MaxBW/lowest latency
P/U15-Processor	LPDDR4x	4266	2666 G4	3733 G4	4266 G4	4266 G2
	LPDDR5/x 1R/2R ³	5200	2400 G4	4800 G4	5200 G4	5200 G2
	LPDDR5/x 1R/2R	4800	2400 G4	4400 G4	4800 G4	4800 G2
	DDR4	3200	2133 G2	2933 G2	3200 G2	2666 G1
	DDR5	4800	2000 G2	4400 G4	4800 G4	4800 G2
U9-Processor	LPDDR4x	4266	2666 G4	3733 G4	4266 G4	4266 G2
	LPDDR5/x 1R/2R	5200	2400 G4	4800 G4	5200 G4	5200 G2

Notes:

1. 12th Generation Intel® Core™ Processors supports dynamic gearing technology where the Memory Controller can run at 1:1 (Gear-1, Legacy mode) or 1:2 (Gear-2 mode) and 1:4 (Gear-4 mode) ratio of DRAM speed. The gear ratio is the ratio of DRAM speed to Memory Controller Clock.
MC Channel Width equal to DDR Channel width multiply by Gear Ratio
2. Type 4 board only.
3. SAGV is not supported on S 125W Processors.
4. SA-GV modes
 - a. **LowBW**- Low frequency point, Minimum Power point. Characterized by low power, low BW, high latency. The system will stay at this point during low to moderate BW consumption.
 - b. **MedBW** - Tuned for balance between power & performance
 - c. **HighBW** Characterized by high power, low latency, moderate BW also used as RFI mitigation point.
 - d. **MaxBW/ lowest latency** Lowest Latency point, low BW and highest power.

DDR Frequency Shifting

DDR interfaces emit electromagnetic radiation which can couple to the antennas of various radios that are integrated in the system, and cause radio frequency interference (RFI).

The DDR Radio Frequency Interference Mitigation (DDR RFIM) feature is primarily aimed at resolving narrowband RFI from DDR4/5 and LPDDR4x/5/5x technologies for the Wi-Fi* high and ultra-high bands (~5-7 GHz).

By changing the DDR data rate, the harmonics of the clock can be shifted out of a radio band of interest, thus mitigating RFI to that radio. This feature is working with SAGV on, the 3rd SAGV point is used as RFI mitigation point.

Memory Controller (MC)

The integrated memory controller is responsible for transferring data between the processor and the DRAM as well as the DRAM maintenance. There are two instances of MC, one per memory slice. Each controller is capable of supporting up to four channels of LPDDR4x and LPDDR5/x, two channels of DDR5 and one channel of DDR4.

The two controllers are independent and have no means of communicating with each other, they need to be configured separately.

In a symmetric memory population, each controller only view half of the total physical memory address space.

Both MC support only one technology in a system DDR4, DDR5, LPDDR4X, or LPDDR5/x. Mix of technologies in one system is not allowed.

Memory Controller Power Gate

Memory Controller Power Gating can only be done for MC0 which is connected to a separate power domain. MC0 will be gated automatically when it is not occupied.

Note: MC1 cannot be gated.

System Memory Controller Organization Mode (DDR4/5 Only)

The IMC supports two memory organization modes, single-channel and dual-channel. Depending upon how the DDR Schema and DIMM Modules are populated in each memory channel, a number of different configurations can exist.

Single-Channel Mode

In this mode, all memory cycles are directed to a single channel. Single-Channel mode is used when either the Channel A or Channel B DIMM connectors are populated in any order, but not both.

Dual-Channel Mode – Intel® Flex Memory Technology Mode

The IMC supports Intel Flex Memory Technology Mode. Memory is divided into a symmetric and asymmetric zone. The symmetric zone starts at the lowest address in each channel and is contiguous until the asymmetric zone begins or until the top address of the channel with the smaller capacity is reached. In this mode, the system runs with one zone of dual-channel mode and one zone of single-channel mode, simultaneously, across the whole memory array.

Note: Channels A and B can be mapped for physical channel 0 and 1 respectively or vice versa; however, channel A size should be greater or equal to channel B size.

Intel® DDR4/5 Flex Memory Technology Operations

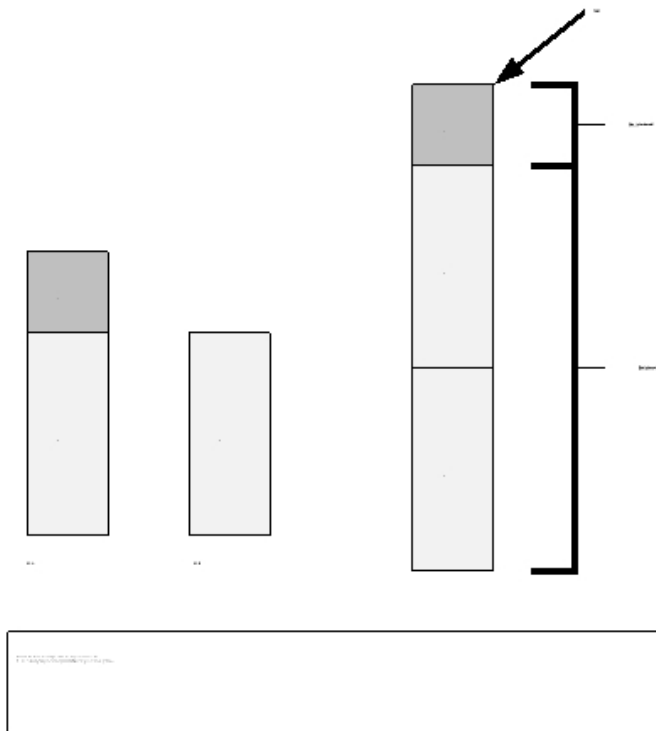

Dual-Channel Symmetric Mode (Interleaved Mode)

Dual-Channel Symmetric mode, also known as interleaved mode, provides maximum performance on real world applications. Addresses are ping-ponged between the channels after each cache line (64-byte boundary). If there are two requests, and the second request is to an address on the opposite channel from the first, that request can be sent before data from the first request has returned. If two consecutive cache lines are requested, both may be retrieved simultaneously, since they are ensured to be on opposite channels. Use Dual-Channel Symmetric mode when both Channel A and Channel B DIMM connectors are populated in any order, with the total amount of memory in each channel being the same.

When both channels are populated with the same memory capacity and the boundary between the dual channel zone and the single channel zone is the top of memory, IMC operates completely in Dual-Channel Symmetric mode.

Notes:

- The DRAM device technology and width may vary from one channel to another.
- Different memory size between channels are relevant to DDR4 and DDR5 only.

System Memory Frequency

In all modes, the frequency of system memory is the lowest frequency and latency of all memory modules placed in the system, as determined through the SPD registers on the memory modules. The system memory controller supports a single DIMM connector per channel. If DIMMs with different latency are populated across the channels, the BIOS will use the slower of the two latencies for both channels. For Dual-Channel modes, both channels should have a DIMM connector populated. For Single-Channel mode, only a single channel can have a DIMM connector populated.

Technology Enhancements of Intel® Fast Memory Access (Intel® FMA)

The following sections describe the Just-in-Time Scheduling, Command Overlap, and Out-of-Order Scheduling Intel FMA technology enhancements.

Just-in-Time Command Scheduling

The memory controller has an advanced command scheduler where all pending requests are examined simultaneously to determine the most efficient request to be issued next. The most efficient request is picked from all pending requests and issued to system memory Just-in-Time to make optimal use of Command Overlapping. Thus, instead of having all memory access requests go individually through an arbitration mechanism forcing requests to be executed one at a time, they can be started without interfering with the current request allowing for concurrent issuing of requests. This allows for optimized bandwidth and reduced latency while maintaining appropriate command spacing to meet system memory protocol.

Command Overlap

Command Overlap allows the insertion of the DRAM commands between the Activate, Pre-charge, and Read/Write commands normally used, as long as the inserted commands do not affect the currently executing command. Multiple commands can be issued in an overlapping manner, increasing the efficiency of system memory protocol.

Out-of-Order Scheduling

While leveraging the Just-in-Time Scheduling and Command Overlap enhancements, the IMC continuously monitors pending requests to system memory for the best use of bandwidth and reduction of latency. If there are multiple requests to the same open page, these requests would be launched in a back to back manner to make optimum use of the open memory page. This ability to reorder requests on the fly allows the IMC to further reduce latency and increase bandwidth efficiency.

Data Scrambling

The system memory controller incorporates a Data Scrambling feature to minimize the impact of excessive di/dt on the platform system memory VRs due to successive 1s and 0s on the data bus. Past experience has demonstrated that traffic on the data bus is not random and can have energy concentrated at specific spectral harmonics creating high di/dt which is generally limited by data patterns that excite resonance between the package inductance and on die capacitances. As a result, the system memory controller uses a data scrambling feature to create pseudo-

random patterns on the system memory data bus to reduce the impact of any excessive di/dt.

Data Swapping

By default, the processor supports on-board data swapping in two manners (for all segments and DRAM technologies): Bit swapping is allowed within each Byte for all DDR technologies.

Bit swapping is allowed within each Byte for all DDR technologies.

LPDDR4x

- x16 sub-channels can be swizzled within their x32 channel
- x32 channels can be swizzled within their x64 MC

LPDDR5/x

- x16 sub-channels can be swizzle within their x64 MC

DDR4: Byte swapping is allowed within each x64 Channel.

DDR5: Byte swapping is allowed within each x32 Channel

ECC bits swap is allowed within ECC byte/nibble: DDR4 ECC[7..0] and DDR5 ECC[3..0].

LPDDR5/x Ascending and Descending

LPDDR5/x support Ascending / descending that swap CA and CS signals connectivity order.

Ascending	Descending
CA6	CA0
CA5	CA1
CA4	CS_1
CA3	CS_0
CA2	CA2
CS_0	CA3
CS_1	CA4
CA1	CA5

Ascending	Descending
CA0	CA6

Note: Ascending / descending can be performed in every x16 sub channel.

LPDDR4x CMD Mirroring

LPDDR4x support Mirroring that swap CA signals connectivity order.

Default	Mirrored
CA 0	CA 5
CA 1	CA 4
CA 2	CA 3
CA 3	CA 2
CA 4	CA 1
CA 5	CA 0

Note: Mirroring can be performed in every x16 sub channel

DDR I/O Interleaving

Note: The processor supports I/O interleaving, which has the ability to swap DDR bytes for routing considerations. BIOS configures the I/O interleaving mode before DDR training. H /P/U-Processor line packages are optimized only for Non-Interleaving mode (NIL).

There are two supported modes:

- Interleave (IL)
- Non-Interleave (NIL)

The following table and figure describe the pin mapping between the IL and NIL modes.

Interleave (IL) and Non-Interleave (NIL) Modes Pin Mapping

IL (DDR4)		NIL (DDR4)		DDR5		NIL(LPDDR4x)		NIL(LPDDR5/x)	
Channel	Byte	Channel	Byte	Channel	Byte	Channel	Byte	Channel	Byte
DDR0	Byte0	DDR0	Byte0	DDR0	Byte0	DDR0	Byte0	DDR0	Byte0
DDR0	Byte1	DDR0	Byte1	DDR0	Byte1	DDR0	Byte1	DDR0	Byte1
DDR0	Byte2	DDR0	Byte4	DDR1	Byte0	DDR2	Byte0	DDR2	Byte0
DDR0	Byte3	DDR0	Byte5	DDR1	Byte1	DDR2	Byte1	DDR2	Byte1
DDR0	Byte4	DDR1	Byte0	DDR2	Byte0	DDR4	Byte0	DDR4	Byte0
DDR0	Byte5	DDR1	Byte1	DDR2	Byte1	DDR4	Byte1	DDR4	Byte1
DDR0	Byte6	DDR1	Byte4	DDR3	Byte0	DDR6	Byte0	DDR6	Byte0
DDR0	Byte7	DDR1	Byte5	DDR3	Byte1	DDR6	Byte1	DDR6	Byte1
DDR1	Byte0	DDR0	Byte2	DDR0	Byte2	DDR1	Byte0	DDR1	Byte0
DDR1	Byte1	DDR0	Byte3	DDR0	Byte3	DDR1	Byte1	DDR1	Byte1
DDR1	Byte2	DDR0	Byte6	DDR1	Byte2	DDR3	Byte0	DDR3	Byte0
DDR1	Byte3	DDR0	Byte7	DDR1	Byte3	DDR3	Byte1	DDR3	Byte1
DDR1	Byte4	DDR1	Byte2	DDR2	Byte2	DDR5	Byte0	DDR5	Byte0
DDR1	Byte5	DDR1	Byte3	DDR2	Byte3	DDR5	Byte1	DDR5	Byte1
DDR1	Byte6	DDR1	Byte6	DDR3	Byte2	DDR7	Byte0	DDR7	Byte0
DDR1	Byte7	DDR1	Byte7	DDR3	Byte3	DDR7	Byte1	DDR7	Byte1

DDR4 Interleave (IL) and Non-Interleave (NIL) Modes Mapping

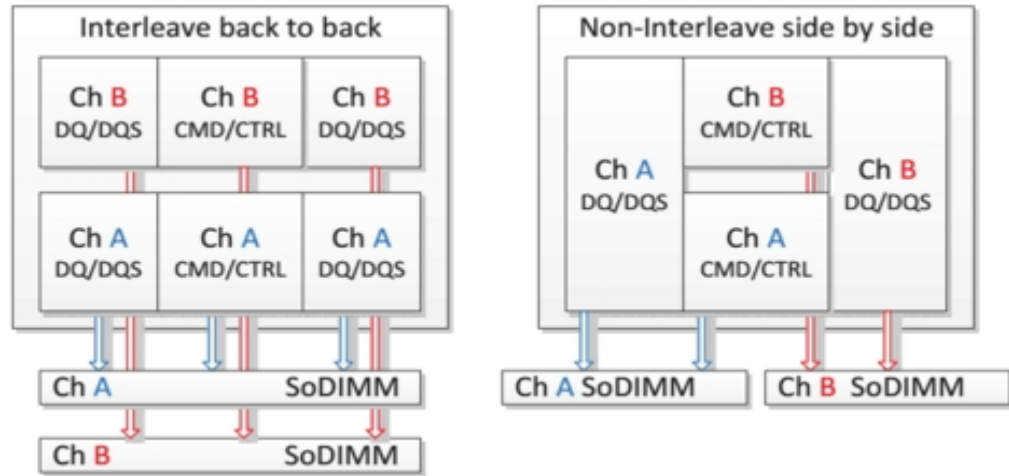

DRAM Clock Generation

Each support rank has a differential clock pair for DDR4/5. Each sub-channel has a differential clock pair for LPDDR4x. Each sub-channel has a (CK_P/N and WCK_P/N) differential clock pair for LPDDR5/x.

DRAM Reference Voltage Generation

Read Vref is generated by the memory controller in all technologies. Write Vref is generated by the DRAM in all technologies. Command Vref is generated by the DRAM in LPDDR4x/LPDDR5/x.

The memory controller generates VrefCA per DIMM for DDR4. In all cases, it has small step sizes and is trained by MRC.

Data Swizzling

All Processor Lines does not have die-to-package DDR swizzling.

Error Correction With Standard RAM

In-Band error-correcting code (IB ECC) correct single-bit memory errors in standard, non-ECC memory.

Supported only in Chrome systems.

Post Package Repair (PPR)

PPR is supported according to Jedec Spec.

BIOS can identify a single Row failure per Bank in DRAM and perform Post Package Repair (PPR) to exchange failing Row with spare Row.

PPR can be supported only with DRAM that supports PPR according to Jedec spec.

Supported technologies : DDR4, LPDDR4x, DDR5 and LPDDR5/x.

Integrated Memory Controller (IMC) Power Management

The main memory is power managed during normal operation and in low-power ACPI C-states.

Disabling Unused System Memory Outputs

Any system memory (SM) interface signal that goes to a memory in which it is not connected to any actual memory devices (such as SODIMM connector is unpopulated, or is single-sided) is tri-stated. The benefits of disabling unused SM signals are:

- Reduced power consumption.
- Reduced possible overshoot/undershoot signal quality issues seen by the processor I/O buffer receivers caused by reflections from potentially unterminated transmission lines.

When a given rank is not populated, the corresponding control signals (CLK_P/CLK_N/CKE/ODT/CS) are not driven.

At reset, all rows should be assumed to be populated, until it can be proven that they are not populated. This is due to the fact that when CKE is tri-stated with a DRAMs present, the DRAMs are not ensured to maintain data integrity. CKE tri-state should be enabled by BIOS where appropriate, since at reset all rows should be assumed to be populated.

DRAM Power Management and Initialization

The processor implements extensive support for power management on the memory interface. Each channel drives 4 CKE pins, one per rank.

The CKE is one of the power-saving means. When CKE is off, the internal DDR clock is disabled and the DDR power is reduced. The power-saving differs according to the selected mode and the DDR type used. For more information, refer to the IDD table in the DDR specification.

The processor supports four different types of power-down modes in package C0 state. The different power-down modes can be enabled through configuring PM PDWN config register. The type of CKE power-down can be configured through PDWN_mode (bits 15:12) and the idle timer can be configured through PDWN_idle_counter (bits 11:0).

The different power-down modes supported are:

- **No power-down:** (CKE disable)
- **Active Power-down (APD):** This mode is entered if there are open pages when de-asserting CKE. In this mode the open pages are retained. Power-saving in this mode is the lowest. Power consumption of DDR is defined by IDD3P. Exiting this mode is fined by tXP – a small number of cycles.

- **Pre-charged Power-down (PPD):** This mode is entered if all banks in DDR are pre-charged when de-asserting CKE. Power-saving in this mode is intermediate – better than APD. Power consumption is defined by IDD2P. Exiting this mode is defined by tXP. The difference from APD mode is that when waking-up, all page-buffers are empty.)

The CKE is determined per rank, whenever it is inactive. Each rank has an idle counter. The idle-counter starts counting as soon as the rank has no accesses, and if it expires, the rank may enter power-down while no new transactions to the rank arrive to queues. The idle-counter begins counting at the last incoming transaction arrival. It is important to understand that since the power-down decision is per rank, the IMC can find many opportunities to power down ranks, even while running memory intensive applications; the savings are significant (may be few Watts, according to DDR specification). This is significant when each channel is populated with more ranks.

Selection of power modes should be according to power-performance or a thermal trade-off of a given system:

- When trying to achieve maximum performance and power or thermal consideration is not an issue: use no power-down
- In a system which tries to minimize power-consumption, try using the deepest power-down mode possible
- In high-performance systems with dense packaging (that is, tricky thermal design) the power-down mode should be considered in order to reduce the heating and avoid DDR throttling caused by the heating.

The idle timer expiration count defines the # of DCLKs that a rank is idle that causes entry to the selected power mode. As this timer is set to a shorter time the IMC will have more opportunities to put the DDR in power-down. There is no BIOS hook to set this register. Customers choosing to change the value of this register can do it by changing it in the BIOS. For experiments, this register can be modified in real time if BIOS does not lock the IMC registers.

Initialization Role of CKE

During power-up, CKE is the only input to the SDRAM that has its level recognized (other than the reset pin) once power is applied. It should be driven LOW by the DDR controller to make sure the SDRAM components float DQ and DQS during power-up. CKE signals remain LOW (while any reset is active) until the BIOS writes to a configuration register. Using this method, CKE is ensured to remain inactive for much longer than the specified 200 micro-seconds after power and clocks to SDRAM devices are stable. In LPDDR5/DDR5, there is no CKE pin and the power management roll is assumed by the CS signals.

Conditional Self-Refresh

During S0 idle state, system memory may be conditionally placed into self-refresh state when the processor is in package C3 or deeper power state. Refer to [Intel® Rapid Memory Power Management \(Intel® RMPM\)](#) for more details on conditional self-refresh with Intel HD Graphics enabled.

When entering the S3 – Suspend-to-RAM (STR) state or S0 conditional self-refresh, the processor IA core flushes pending cycles and then enters SDRAM ranks that are not used by the processor graphics into self-refresh. The CKE signals remain LOW so the SDRAM devices perform self-refresh.

The target behavior is to enter self-refresh for package C3 or deeper power states as long as there are no memory requests to service.

Dynamic Power-Down

Dynamic power-down of memory is employed during normal operation. Based on idle conditions, a given memory rank may be powered down. The IMC implements aggressive CKE control to dynamically put the DRAM devices in a power-down state.

The processor IA core controller can be configured to put the devices in active power down (CKE de-assertion with open pages) or pre-charge power-down (CKE de-assertion with all pages closed). Pre-charge power-down provides greater power savings but has a bigger performance impact, since all pages will first be closed before putting the devices in power-down mode.

If dynamic power-down is enabled, all ranks are powered up before doing a refresh cycle and all ranks are powered down at the end of the refresh.

DRAM I/O Power Management

Unused signals should be disabled to save power and reduce electromagnetic interference. This includes all signals associated with an unused memory channel. Clocks, CKE, ODT, and CS signals are controlled per DIMM rank and will be powered down for unused ranks.

The I/O buffer for an unused signal should be tri-stated (output driver disabled), the input receiver (differential sense-amp) should be disabled. The input path should be gated to prevent spurious results due to noise on the unused signals (typically handled automatically when input receiver is disabled).

DDR Electrical Power Gating

The DDR I/O of the processor supports Electrical Power Gating (DDR-EPG) while the processor is at C3 or deeper power state.

In C3 or deeper power state, the processor internally gates VDDQ and VDD2 for the majority of the logic to reduce idle power while keeping all critical DDR pins such as CKE and VREF in the appropriate state.

In C7 or deeper power state, the processor internally gates VCCSA for all non-critical state to reduce idle power.

In S3 or C-state transitions, the DDR does not go through training mode and will restore the previous training information.

Power Training

BIOS MRC performing Power Training steps to reduce DDR I/O power while keeping reasonable operational margins still guaranteeing platform operation. The algorithms attempt to weaken ODT, driver strength and the related buffers parameters both on the MC and the DRAM side and find the best possible trade-off between the total I/O power and the operating margins using advanced mathematical models.

USB-C* Sub System

USB-C* is a cable and connector specification defined by USB-IF.

The USB-C sub-system supports USB3, USB4, DPoC (DisplayPort over Type-C) protocols. The USB-C sub-system can also support be configured as native DisplayPort or HDMI interfaces, for more information refer to [Display](#).

Thunderbolt™ 4 is a USB-C solution brand which requires the following elements:

- USB2, USB3 (10 Gbps), USB3/DP implemented at the connector.
- In additional, it requires USB4 implemented up to 40 Gbps, including Thunderbolt 3 compatibility as defined by USB4/USB-PD specs and 15 W of bus power
- Thunderbolt 4 solutions use (and prioritize) the USB4 PD entry mode (while still supporting Thunderbolt 3 alt mode)
- This product has the ability to support these requirements

Note: If USB4 (20 Gbps) only solutions are implemented, Thunderbolt 3 compatibility as defined by USB4/USB-PD specs and 15 W of bus power are still recommended

General Capabilities

- xHCI (USB 3 host controller) and xDCI (USB 3 device controller) implemented in the processor in addition to the controllers in the PCH.
- No support for USB Type-A on the processor side, For USB Type-A implementation and capabilities refer to Intel® 600 Series Chipset Family On-Package Platform Controller Hub (PCH) Datasheet, Volume 1 of 2 ([691222](#)).
- Intel AMT/vPro over Thunderbolt docking.
- Support power saving when USB-C* disconnected.
- Support up to four simultaneous ports.
- DbC Enhancement for Low Power Debug until Pkg C6
- Host
 - Aggregate BW through the controller at least 3 GB/s, direct connection or over USB 4.
 - Wake capable on each host port from S0i3, Sx: Wake on Connects, Disconnects, Device Wake.
- Device
 - Aggregate BW through xHCI controller of at least 3 GB/s
 - D0i2 and D0i3 power gating
 - Wake capable on host initiated wakes when the system is in S0i3, Sx Available on all ports
- Port Routing Control for Dual Role Capability
 - Needs to support SW/FW and ID pin based control to detect host versus device attach



- SW mode requires PD controller or other FW to control
- USB-R device to host controller connection is over UTMI+ links.

USB-C* Port Configuration

	Port	H/P/U15 - Processor Line	U9 - Processor Line
Group A	TCP 0	USB 4 ⁴ USB 3 ³ DisplayPort ¹ HDMI ²	USB 4 ⁴ , DisplayPort ¹ , USB 3 ³ , HDMI ²
	TCP 1		
Group B	TCP 2		N/A
	TCP 3		

	Port	H/P/U15 - Processor Line	U9 - Processor Line
<p>Notes:</p> <ol style="list-style-type: none"> 1. Supported on Type-C or Native connector 2. Supported only on Native connector. 3. USB 3 supported link rates: <ol style="list-style-type: none"> a. USB 3 Gen 1x1 (5 Gbps) b. USB 3 Gen 2x1 (10 Gbps) 4. USB4 operating link rates (including both rounded and non-rounded modes for Thunderbolt 3 compatibility): <ol style="list-style-type: none"> a. USB 4 Gen 2x2 (20 Gbps) b. USB 4 Gen 3x2 (40 Gbps) c. 10.3125 Gbps, 20.625 Gbps - Compatible to Thunderbolt 3 non-rounded modes. 5. USB 2 interface supported over Type-C connector, sourced from PCH. 6. USB Type-A connector is not supported. 7. Port group is defined as two ports sharing the same USB4 router, each router supports up to two display interfaces. 8. display interface can be connected directly to a DP/HDMI/Type-C port or thru USB 4 router on a Type-C connector. 9. If two ports in the same group are configured to one as USB4 and the other as DP/HDMI fixed connection each port will support single display interface. 			

USB-C* Lanes Configuration

Lane1	Lane2	Comments
USB 4	USB 4	Both lanes operate at Gen 2 (10G) or Gen 3 (20G) and also support non-rounded frequencies (10.3125G / 20.625G) for TBT3 compatibility.
USB3	No connect	Any combination of <ul style="list-style-type: none"> • USB3.2 Gen 1x1 (5 Gbps) • USB3.2 Gen 2x1 (10 Gbps)

Lane1	Lane2	Comments
No connect	USB3	
USB3	DPx2	Any of HBR3/HBR2/HBR1/RBR for DP and USB3.2 (10 Gbps)
DPx2	USB3	
DPx4		Both lanes at the same DP rate - no support for 2x DPx2 USB-C connector

USB-C* Non-Supported Lane Configuration

Lane1	Lane2	Comments
#	PCIe* Gen3/2/1	No PCIe* native support
PCIe* Gen3/2/1	#	
#	USB4	No support for USB4 with any other protocol
USB4	#	

USB™ 4 Router

USB4 is a Standard architecture (formerly known as CIO), but with the addition of USB3 (10G) tunneling, and rounded frequencies. USB4 adds a new USB4 PD entry mode, but fully documents mode entry, and negotiation elements of Thunderbolt™ 3.

USB4 architecture (formerly known as Thunderbolt 3 protocol) is a transformational high-speed, dual protocol I/O, and it provides flexibility and simplicity by encapsulating both data (PCIe* & USB3) and video

(DisplayPort*) on a single cable connection that can daisy-chain up to six devices.

USB4/Thunderbolt controllers act as a point of entry or a point of exit in the USB4 domain. The USB4 domain is built as a daisy chain of USB4/Thunderbolt enabled products for the encapsulated protocols - PCIe, USB3 and DisplayPort. These protocols are encapsulated into the USB4 fabric and can be tunneled across the domain.

USB4 controllers can be implemented in various systems such as PCs, laptops and tablets, or devices such as storage, docks, displays, home entertainment, cameras, computer peripherals, high end video editing systems, and any other PCIe based device that can be used to extend system capabilities outside of the system's box.

The integrated connection maximum data rate is 20.625 Gbps per lane but supports also 20.0 Gbps, 10.3125 Gbps, and 10.0 Gbps and is compatible with older Thunderbolt™ device speeds.

USB 4 Host Router Implementation Capabilities

The integrated USB-C sub-system implements the following interfaces via USB 4:

- Up to two DisplayPort* sink interfaces each one capable of:
 - DisplayPort 1.4 specification for tunneling
 - 1.62 Gbps or 2.7 Gbps or 5.4 Gbps or 8.1 Gbps link rates
 - x1, x2 or x4 lane operation
 - Support for DSC compression
- Up to two PCI Express* Root Port interfaces each one capable of:
 - PCI Express* 3.0 x4 compliant @ 8.0 GT/s
- Up to two xHCI Port interfaces each one capable of:
 - USB 3.2 Gen2x1 (10 Gbps)
- USB 4 Host Interface:
 - PCI Express* 3.0 x4 compliant endpoint
 - Supports simultaneous transmit and receive on 12 paths
 - Raw mode and frame mode operation configurable on a per-path basis
 - MSI and MSI-X support
 - Interrupt moderation support
- USB 4 Time Management Unit (TMU):
- Up to two Interfaces to USB-C* connectors, each one supports:
 - USB4 PD entry mode, as well as TBT 3 compatibility mode, each supporting:
 - 20 paths per port
 - Each port support 20.625/20.0 Gbps or 10.3125/10.0 Gbps link rates.
 - 16 counters per port

USB-C Sub-system xHCI/xDCI Controllers

The processor supports xHCI/xDCI controllers. The native USB 3 path proceeds from the memory directly to PHY.

USB 3 Controllers

Extensible Host Controller Interface (xHCI)

Extensible Host Controller Interface (xHCI) is an interface specification that defines Host Controller for a universal Serial Bus (USB 3), which is capable of interfacing with USB 1.x, 2.0, and 3.x compatible devices.

In case that a device (example, USB3 mouse) was connected to the computer, the computer will work as Host and the xHCI will be activated inside the CPU.

The xHCI controller support link rate of up to USB 3.2 Gen 2x1 (10G).

Extensible Device Controller Interface (xDCI)

Extensible Device Controller Interface (xDCI) is an interface specification that defines Device Controller for a universal Serial Bus (USB 3), which is capable of interfacing with USB 1.x, 2.0, and 3.x compatible devices.

In case that the computer is connected as a device (example, tablet connected to desktop) to another computer then the xDCI controller will be activated inside the device and will talk to the Host at the other computer.

The xDCI controller support link rate of up to USB 3.2 Gen 1x1 (5G).

Note: These controllers are instantiated in the processor die as a separate PCI function functionality for the USB-C* capable ports.

USB-C Sub-System PCIe Interface

PCIe via USB4 Configuration

USB4 IPs	USB4_PCIe	H/P/U15 USB-C* Ports	U9 USB-C* Ports
USB4_DMA0	USB4_PCIE0	TCP0	TCP0
	USB4_PCIE1	TCP1	TCP1
USB4_DMA1	USB4_PCIE2	TCP2	N/A
	USB4_PCIE3	TCP3	

USB-C Sub-System Display Interface

Refer [Display](#).

PCIe* Interface

Processor PCI Express* Interface

This section describes the PCI Express* interface capabilities of the processor. Refer to *PCI Express Base* Specification 5.0* for details on PCI Express*.

Note: PCIe Gen 5.0 is not supported on H/P/U Processor Lines due to Gen 5.0 device non-availability at TTM. The below applies for PCIe Gen4.0 and lower

PCI Express* Support

The S-processor PCI Express* has two interfaces:

- 16-lane (x16) port supporting PCIe to gen 5.0 or below that can also be configured as multiple ports at narrower widths.
- 4-lane (x4) port supporting PCIe gen 4.0 or below.

The H processor Line PCI Express* has two interfaces:

- One 8-lane (x8) port supporting PCIe to gen 4.0 or below. This interface is available on certain SKU
- Two 4-lane (x4) port supporting PCIe gen 4.0 or below.

The P processor Line PCI Express* has two interfaces:

- Two 4-lane (x4) port supporting PCIe gen 4.0 or below.

The U15 processor PCI Express* has two interfaces:

- Two 4-lane (x4) port supporting PCIe gen 4.0 or below.

The U9 processor PCI Express* has one interface:

- One 4-lane (x4) port supporting PCIe gen 4.0 or below.

The processor supports the following:

- Hierarchical PCI-compliant configuration mechanism for downstream devices.
- Traditional PCI style traffic (asynchronous snooped, PCI ordering).
- PCI Express* extended configuration space. The first 256 bytes of configuration space aliases directly to the PCI Compatibility configuration space. The remaining portion of the fixed 4-KB block of memory-mapped space above that (starting at 100h) is known as extended configuration space.
- PCI Express* Enhanced Access Mechanism. Accessing the device configuration space in a flat memory-mapped fashion.



- Automatic discovery, negotiation, and training of link out of reset.
- Multiple Virtual Channel for Gen 4 port only*.
- 64-bit downstream address format, but the processor never generates an address above 4096 GB (Bits 63:43 will always be zeros).
- 64-bit upstream address format, but the processor responds to upstream read transactions to addresses above 4096 GB (addresses where any of Bits 63:43 are nonzero) with an Unsupported Request response. Upstream write transactions to addresses above 4096 GB will be dropped.
- Re-issues Configuration cycles that have been previously completed with the Configuration Retry status.
- PCI Express* reference clock is a 100-MHz differential clock.
- Power Management Event (PME) functions.
- Modern standby
- Dynamic width capability.
- Message Signaled Interrupt (MSI and MSI-X) messages.
- Lane reversal
- Advanced Error Reporting (AER)
- MCTP VDM tunneling.
- ACS - Access control services
- Hotplug is supported on PEG60/62 only. It is not supported on PEG10/11
- Precision Time Measurement (PTM) - This feature is supported on PEG60/62 with the exception of ECN for byte ordering of the PTM value not being supported. PEG10/11 do support ECN for byte ordering

The S processor supports the configurations shown in the following tables:

PCI Express* 16 - Lane Bifurcation and Lane Reversal Mapping

	Link Width		CFG Signals			Lanes															
			CFG	CFG	CFG	0	1	2	3	4	5	6	7	8	9	10	11	12	13	14	15
Bifurcation	0:1:0:1:1	0:1:1	[6]	[5]	[2]	0	1	2	3	4	5	6	7	8	9	10	11	12	13	14	15
PCIe controller						PCIe 010															
1x16	x16	N/A	1	1	1	0	1	2	3	4	5	6	7	8	9	10	11	12	13	14	15

	Link Width		CFG Signals			Lanes															
	0:1:0:1:1	0:1:1	CFG [6]	CFG [5]	CFG [2]	0	1	2	3	4	5	6	7	8	9	10	11	12	13	14	15
1x16 Reversed	x16	N/A	1	1	0	15	14	13	12	11	10	9	8	7	6	5	4	3	2	1	0
PCIe controller						PCIe 010								PCIe 011							
2x8	x8	x8	1	0	1	0	1	2	3	4	5	6	7	0	1	2	3	4	5	6	7
PCIe controller						PCIe 011								PCIe 010							
2x8 Reversed	x8	x8	1	0	0	7	6	5	4	3	2	1	0	7	6	5	4	3	2	1	0

Notes:

- For CFG bus details, refer to [Reset and Miscellaneous Signals](#).
- Support is also provided for narrow width and use devices with lower number of lanes (that is, usage on x4 configuration), however further bifurcation is not supported.
- In case that more than one device is connected, the device with the highest lane count, should always be connected to the lower lanes, as follows:
 - Connect lane 0 of 1st device to lane 0.
 - Connect lane 0 of 2nd device to lane 8.
- For reversal lanes, for example: When using 1x8, the 8 lane device should use lanes 8:15, so lane 15 will be connected to lane 0 of the Device.

S- Processor PCI Express* 4 - Lane Reversal Mapping

	Link Width	CFG Signals	Lanes
--	------------	-------------	-------



	0:6:0	CFG [14]	0	1	2	3
PCIe controller			PCIe 060			
1x4	x4	1	0	1	2	3
1x4 Reversed	x4	0	3	2	1	0
<p>Note: PCIe* Port60 is a single x4 port without bifurcation capabilities, thus bifurcation pin straps are not applicable.</p>						

The H/P/U15 processor Lines supports the configurations shown in the following tables:

H-Processor Line PCI Express* 8 - Lane Reversal Mapping

Bifurcation	Link Width		CFG Signals			Lanes							
	0:1:0	0:1:1	CFG [6]	CFG [5]	CFG [2]	0	1	2	3	4	5	6	7
PCIe controller			PCIe 010										
1x8	x8	N/A	1	1	1	0	1	2	3	4	5	6	7
1x8 Reversed	x8	N/A	1	1	0	7	6	5	4	3	2	1	0
<p>Notes:</p> <ol style="list-style-type: none"> For CFG bus details, refer to Reset and Miscellaneous Signals. Support is also provided for narrow width and use devices with lower number of lanes (that is, usage on x4 configuration), however further bifurcation is not supported. For reversal lanes, for example: When using 1x4, the 4 lane device should use lanes 4:7, so lane 7 will be connected to lane 0 of the Device. 													

The H/P/U15 processor supports the configurations shown in the following tables:

H/P/U15-Processor Line PCI Express* 4 - Lane Reversal Mapping

Bifurcation	Link Width		CFG Signals		Lanes			
	0:6:0	0:6:2	CFG [14]	CFG [15]	0	1	2	3
PCIe Controller					PCIe 060			
1x4	x4	NA	1	1	0	1	2	3
1x4 Reversed	x4	NA	0	1	3	2	1	0
PCIe Controller					PCIe 062			
1x4	NA	x4	1	1	0	1	2	3
1x4 Reversed	NA	x4	1	0	3	2	1	0

The U9 processor supports the configurations shown in the following tables:

U9-Processor PCI Express* 4 - Lane Reversal Mapping

Bifurcation	Link Width		CFG Signals		Lanes			
	0:6:0	0:6:2	CFG [14]	CFG [15]	0	1	2	3
PCIe controller					PCIe 060			
1x4	x4	NA	1	1	0	1	2	3
1x4 Reversed	x4	NA	0	1	3	2	1	0

PCI Express* Maximum Transfer Rates and Theoretical Bandwidth

PCI Express* Generation	Encoding	Maximum Transfer Rate [GT/s]	Theoretical Bandwidth [GB/s]		
			S/H/P/U x4	S/H x8	S x16
Gen 1	8b/10b	2.5	1.0	2.0	4.0
Gen 2	8b/10b	5	2.0	4.0	8.0
Gen 3	128b/130b	8	3.9	7.9	15.8
Gen 4	128b/130b	16	7.9	15.8	31.5
Gen 5	128b/130b	32 ¹	15.8 ¹	31.5 ¹	63 ¹

Note:
1. Transfer rate and max theoretical Bandwidth are not final and could be lowered.

The above table summarizes the transfer rates and theoretical bandwidth of PCI Express* link.

PCI Express* Architecture

Compatibility with the PCI addressing model is maintained to ensure that all existing applications and drivers operate unchanged.

The PCI Express* configuration uses standard mechanisms as defined in the PCI Plug-and-Play specification.

The processor PCI Express* port supports Gen 4 at 16GT/s uses a 128b/130b encoding and Gen 5 at 32 GT/s uses a 128b/130b encoding

S/HX-Processor Line: The 4 lanes port can operate at 2.5 GT/s, 5 GT/s, 8 GT/s or 16 GT/s.

S/HX-Processor Line: The 16 lanes port can operate at 2.5 GT/s, 5 GT/s, 8 GT/s, 16 GT/s or 32 GT/s**

H/P/U-Processor Line: Each of the 4 lanes ports can operate at 2.5 GT/s, 5 GT/s, 8 GT/s or 16 GT/s.

H-Processor Line: The 8 lane port can operate at 2.5 GT/s, 5 GT/s, 8 GT/s, or 16 GT/s**

U9-Processor : The 4 lanes port can operate at 2.5 GT/s, 5 GT/s, 8 GT/s or 16 GT/s.

The PCI Express* architecture is specified in three layers – Transaction Layer, Data Link Layer, and Physical Layer. Refer to the PCI Express Base Specification 5.0 for details of PCI Express* architecture.

PCI Express* Configuration Mechanism

The PCI Express* (external graphics) link is mapped through a PCI-to-PCI bridge structure.

PCI Express* Related Register Structures in the Processor

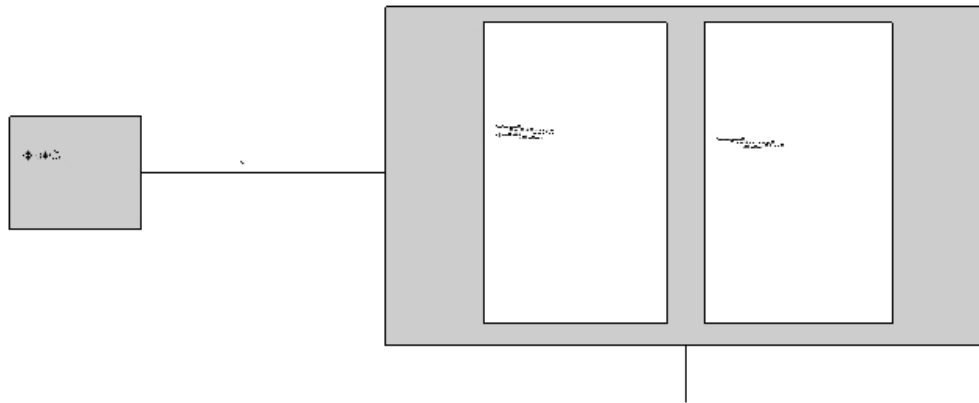

The PCI Express* Host Bridge is required to translate the memory-mapped PCI Express* configuration space accesses from the host processor to PCI Express* configuration cycles. To maintain compatibility with PCI configuration addressing mechanisms, it is recommended that system software access the enhanced configuration space using 32-bit operations (32-bit aligned) only. Refer to the PCI Express Base Specification for details of both the PCI-compatible and PCI Express* Enhanced configuration mechanisms and transaction rules.

PCI Express* Equalization Methodology

Link equalization requires equalization for both TX and RX sides for the processor and for the Endpoint device.

Adjusting transmitter and receiver of the lanes is done to improve signal reception quality and for improving link robustness and electrical margin.

The link timing margins and voltage margins are strongly dependent on equalization of the link.

The processor supports the following:

- **Full TX Equalization:** Three Taps Linear Equalization (Pre, Current and Post cursors), with FS/LF (Full Swing /Low Frequency) values.
- Full RX Equalization and acquisition for AGC (Adaptive Gain Control), CDR (Clock and Data Recovery), adaptive DFE (decision feedback equalizer) and adaptive CTLE peaking (continuous time linear equalizer).
- Full adaptive phase 3 EQ compliant with PCI Express* Gen 3 and Gen 4 specification.

PCI Express* Hot Plug

PCI Express Hot Plug not supported.

Direct Media Interface and On Package Interface

Direct Media Interface (DMI)

Note: The DMI interface is only present in 2-Chip platform processors.

Direct Media Interface (DMI) connects the processor and the PCH.

The main characteristics are as follows:

- 8 lanes Gen 4 DMI support
- 4 lanes Gen 4 Reduced DMI support
- 16 GT/s point-to-point DMI interface to PCH
- DC coupling - no capacitors between the processor and the PCH
- PCH end-to-end lane reversal across the link
- L0 (Active) and L1 (Low power) states support
- Half-Swing support (low-power/low-voltage)

DMI Lane Reversal and Polarity Inversion

Note: Polarity Inversion and Lane Reversal on DMI Link are not allowed in S-Processor segment. Lane reversal can only be allowed on the PCH side.

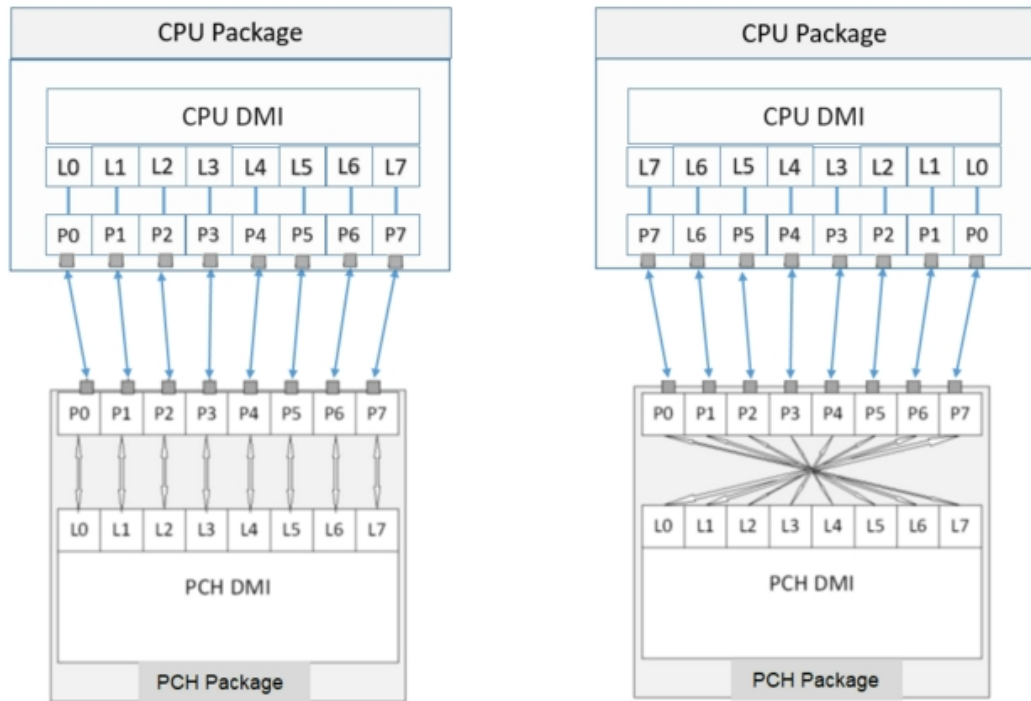
Example for DMI Lane Reversal Connection

1. DMI Lane Reversal is supported only on PCH-H and not on the Processor.
2. L[7:0] - Processor and PCH DMI Controller Logical Lane Numbers.
3. P[7:0] - Processor and PCH DMI Package Pin Lane Numbers.

DMI Error Flow

DMI can only generate SERR in response to errors; never SCI, SMI, MSI, PCI INT, or GPE. Any DMI related SERR activity is associated with Device 0.

DMI Link Down

The DMI link going down is a fatal, unrecoverable error. If the DMI data link goes to data link down, after the link was up, then the DMI link hangs the system by not allowing the link to retrain to prevent data corruption. This link behavior is controlled by the PCH.

Downstream transactions that had been successfully transmitted across the link prior to the link going down may be processed as normal. No completions from downstream, non-posted transactions are returned upstream over the DMI link after a link down event.

On Package Interface (OPI)

OPI Support

The processor communicates with the PCIe using an internal interconnect BUS named OPI.

Functional Description

OPI operates at 4 GT/s bus rate.

Graphics

Processor Graphics

The processor graphics is based on X^e graphics core architecture that enables substantial gains in performance and lower-power consumption over prior generations. X^e architecture supports up to 96 Execution Units (EUs) depending on the processor SKU.

The processor graphics architecture delivers high dynamic range of scaling to address segments spanning low power to high power, increased performance per watt, support for next generation of APIs. X^e scalable architecture is partitioned by usage domains along Render/Geometry, Media, and Display. The architecture also delivers very low-power video playback and next generation analytics and filters for imaging related applications. The new Graphics Architecture includes 3D compute elements, Multi-format HW assisted decode/encode pipeline, and Mid-Level Cache (MLC) for superior high definition playback, video quality, and improved 3D performance and media.

Media Support (Intel® QuickSync and Clear Video Technology HD)

X^e implements multiple media video codecs in hardware as well as a rich set of image processing algorithms.

Note: HEVC and VP9 support additional 10bpc, YCbCr 4:2:2 or 4:4:4 profiles. Refer additional detail support matrix.

Hardware Accelerated Video Decode

X^e implements a high-performance and low-power HW acceleration for video decoding operations for multiple video codecs.

The HW decode is exposed by the graphics driver using the following APIs:

- Direct3D* 9 Video API (DXVA2)
- Direct3D11 Video API
- Direct3D12 Video API
- Intel Media SDK
- MFT (Media Foundation Transform) filters.
- Intel VA API

X^e supports full HW accelerated video decoding for AVC/HEVC/VP9/JPEG/AV1.

Hardware Accelerated Video Decoding

Codec	Profile	Level	Maximum Resolution
WMV9	Advanced	L3	3840x3840
	Main	High	
	Simple	Simple	
AVC/H264	High	L5.2	4K
	Main		4K @ 60
	4:2:0 8bit		
JPEG/MJPEG	Baseline	Unified level	16K x16K
HEVC/H265	Main 12	L6.1	5K @ 60 8K @ 60
	Main 422 10		
	Main 422 12		
	Main 444		
	Main 444 10		
	Main 444 12		
	SCC main		
	SCC main 10		
	SCC main 444		
	SCC main 444 10		
VP9	1 (4:2:0 4:4:4 8 bit)	Unified level	4K @ 60
	3 (4:2:0 4:4:4 10/12bit)		8K @ 60

Codec	Profile	Level	Maximum Resolution
AV1	0 (4:2:0 8-bit) 0 (4:2:0 10-bit)	L6.1	8K @ 60 (video) 16K x 16K (still picture)

Note:

Video playback best performance can be achieved by enabling display MPO with minimized EU workloads. In some test scenarios, it may act differently.

For example, 8k playback on less than 8k monitors, in non-full screen mode or some UI operations and unexpected end user behaviors etc. - These will hit MPO limitation or simply applications do not use MPO.

Then graphics driver need to use EU for rendering/composition, and 8K E2E playback has dependency on EU counts capability.

Expected performance: More than 16 simultaneous decode streams @ 1080p.

Note: Actual performance depends on the processor SKU, content bit rate, and memory frequency. Hardware decode for H264 SVC is not supported.

Hardware Accelerated Video Encode

Gen12 implements a low-power low-latency fixed function encoder and a high-quality customizable encoder with hardware assisted motion estimation engine which supports AVC, MPEG-2, HEVC, and VP9.

The HW encode is exposed by the graphics driver using the following APIs:

- Intel® Media SDK
- MFT (Media Foundation Transform) filters

X^e supports full HW accelerated video encoding for AVC/HEVC/VP9/JPEG.

Hardware Accelerated Video Encode

Codec	Profile	Level	Maximum Resolution
AVC/H264	High Main	L5.1	2160p(4K)

Codec	Profile	Level	Maximum Resolution
JPEG	Baseline	—	16Kx16K
HEVC/H265	Main Main10 Main 4:2:2 10 Main 4:4:4 Main 4:4:4 10	L5.1	4320p(8K) 16Kx4K @higher freq
VP9	0 (4:2:0 Chroma 8 bit) 1 (partial: 4:4:4 8 bit) 2 (partial: 4:2:0 10 bit) 3 (partial: 4:4:4 10 bit)	—	4320p(8K) 16Kx4K @higher freq

Note: Hardware encode for H264 SVC is not supported.

Hardware Accelerated Video Processing

There is hardware support for image processing functions such as De-interlacing, Film cadence detection, Advanced Video Scaler (AVS), detail enhancement, gamut compression, HD adaptive contrast enhancement, skin tone enhancement, total color control, Chroma de-noise, SFC (Scalar and Format Conversion), memory compression, Localized Adaptive Contrast Enhancement (LACE), spatial de-noise, Out-Of-Loop De-blocking (from AVC decoder), 16 bpc support for de-noise/de-mosaic.

The HW video processing is exposed by the graphics driver using the following APIs:

- Direct3D* 9 Video API (DXVA2).
- Direct3D* 11 Video API.
- OneVPL
- MFT (Media Foundation Transform) filters.
- Intel® Graphics Control Library
- Intel VA API

Note: Not all features are supported by all the above APIs. Refer to the relevant documentation for more details.

Hardware Accelerated Transcoding

Transcoding is a combination of decode, video processing (optional) and encode. Using the above hardware capabilities can accomplish a high-performance transcode pipeline. There is not a dedicated API for transcoding.

The processor graphics supports the following transcoding features:

- High performance high quality flexible encoder for video editing, video archiving.
- Low-power low latency encoder for video conferencing, wireless display, and game streaming.
- Lossless memory compression for media engine to reduce media power.
- High-quality Advanced Video Scaler (AVS)
- Low power Scaler and Format Converter.

Platform Graphics Hardware Feature

Hybrid Graphics

Microsoft* Windows* operating system enables the Windows* Hybrid graphics framework wherein the GPUs and their drivers can be simultaneously utilized to provide users with the benefits of both performance capability of discrete GPU (dGPU) and low-power display capability of the processor GPU (iGPU). For instance, when there is a high-end 3D gaming workload in progress, the dGPU will process and render the game frames using its graphics performance, while iGPU continues to perform the display operations by compositing the frames rendered by dGPU. We recommend that OEMS should seek further guidance from Microsoft* to confirm that the design fits all the latest criteria defined by Microsoft* to support HG.

Microsoft* Hybrid Graphics definition includes the following:

1. The system contains a single integrated GPU and a single discrete GPU.
2. It is a design assumption that the discrete GPU has a significantly higher performance than the integrated GPU.
3. Both GPUs shall be physically enclosed as part of the system.
 - a. Microsoft* Hybrid DOES NOT support hot-plugging of GPUs
 - b. OEMS should seek further guidance from Microsoft* before designing systems with the concept of hot-plugging
4. Starting with Windows*10 Th1 (WDDM 2.0), a previous restriction that the discrete GPU is a render-only device, with no displays connected to it, has been removed. A render-only configuration with NO outputs is still allowed, just NOT required.

Display

Display Technologies Support

Technology	Standard
eDP* 1.4b	VESA* Embedded DisplayPort* Standard 1.4b
MIPI DSI	MIPI* DSI 2 Specification Version 1.0 MIPI* DPHY Specification Version 2.0
DisplayPort* 1.4a	VESA* DisplayPort* Standard 1.4a VESA* DisplayPort* PHY Compliance Test Specification 1.4a VESA* DisplayPort* Link Layer Compliance Test Specification 1.4 VESA* DisplayPort* Alt Mode on USB Type-C Standard Version 1.0b
HDMI* 2.1	High-Definition Multimedia Interface Specification Version 2.1
<p>Notes:</p> <ul style="list-style-type: none"> • Processor support native HDMI* 2.1 TMDS compatible ports • Processor support non-native HDMI* 2.1 port by using DP*to HDMI* protocol converter. 	

Display Configuration

Display Ports Availability and Link Rate for H/P/U - Processor Lines

Port	S-Processor Line	H/P Processor Line ⁴	U15 Processor ⁴	U9 Processor ⁴

Port	S-Processor Line	H/P Processor Line ⁴	U15 Processor ⁴	U9 Processor ⁴
DDI A	eDP* up to HBR3 DP* up to HBR3 ¹ HDMI* up to 5.94 Gbps	eDP* up to HBR3 MIPI DSI up to 2.5 Gbps DP* up to HBR3 ¹ HDMI* up to 5.94 Gbps	eDP* up to HBR3 MIPI DSI up to 2.5 Gbps DP* up to HBR3 ¹ HDMI* up to 5.94 Gbps	eDP* up to HBR3 MIPI DSI up to 2.5 Gbps DP* up to HBR3 ¹ HDMI* up to 5.94 Gbps
DDI B	DP* up to HBR3 ¹ HDMI* up to 5.94 Gbps	eDP* up to HBR3 MIPI DSI up to 2.5 Gbps DP* up to HBR3 ¹ HDMI* up to 5.94 Gbps	eDP* up to HBR3 MIPI DSI up to 2.5 Gbps DP* up to HBR3 ¹ HDMI* up to 5.94 Gbps	eDP* up to HBR3 MIPI DSI up to 2.5 Gbps DP* up to HBR3 ¹ HDMI* up to 5.94 Gbps
DDI C	DP* up to HBR3 ¹ HDMI* up to 5.94 Gbps	N/A	N/A	N/A
DDI D	DP* up to HBR3 ¹ HDMI* up to 5.94 Gbps	N/A	N/A	N/A
DDI E	DP* up to HBR3 ¹ HDMI* up to 5.94 Gbps	N/A	N/A	N/A
TCP 0	N/A	DP* up to HBR3 HDMI* up to 5.94 Gbps	DP* up to HBR3 HDMI* up to 5.94 Gbps	DP* up to HBR3 HDMI* up to 5.94 Gbps

Port	S-Processor Line	H/P Processor Line ⁴	U15 Processor ⁴	U9 Processor ⁴
TCP 1	N/A	DP* up to HBR3 HDMI* up to 5.94 Gbps	DP* up to HBR3 HDMI* up to 5.94 Gbps	DP* up to HBR3 HDMI* up to 5.94 Gbps
TCP 2	N/A	DP* up to HBR3 HDMI* up to 5.94 Gbps	DP* up to HBR3 HDMI* up to 5.94 Gbps	N/A
TCP 3	N/A	DP* up to HBR3 HDMI* up to 5.94 Gbps	DP* up to HBR3 HDMI* up to 5.94 Gbps	

Notes:

1. On board re-timer is required.
2. HBR3 - 8.1 Gbps lane rate.
3. HBR2 - 5.4 Gbps lane rate.
4. Dual Embedded panels supported on P/H/U15 Processor lines using Port A and B

S Processor Display Architecture

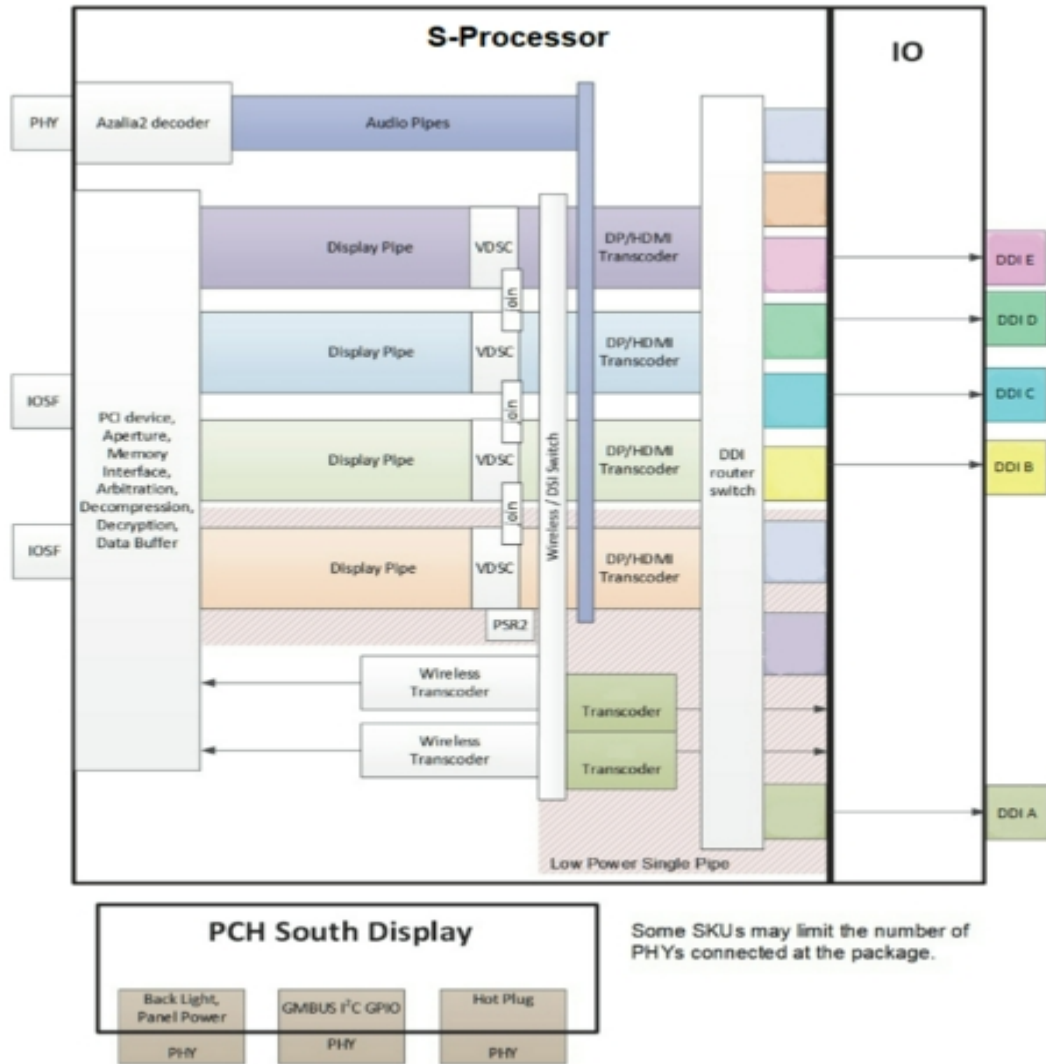

H/P/U Processor Display Architecture

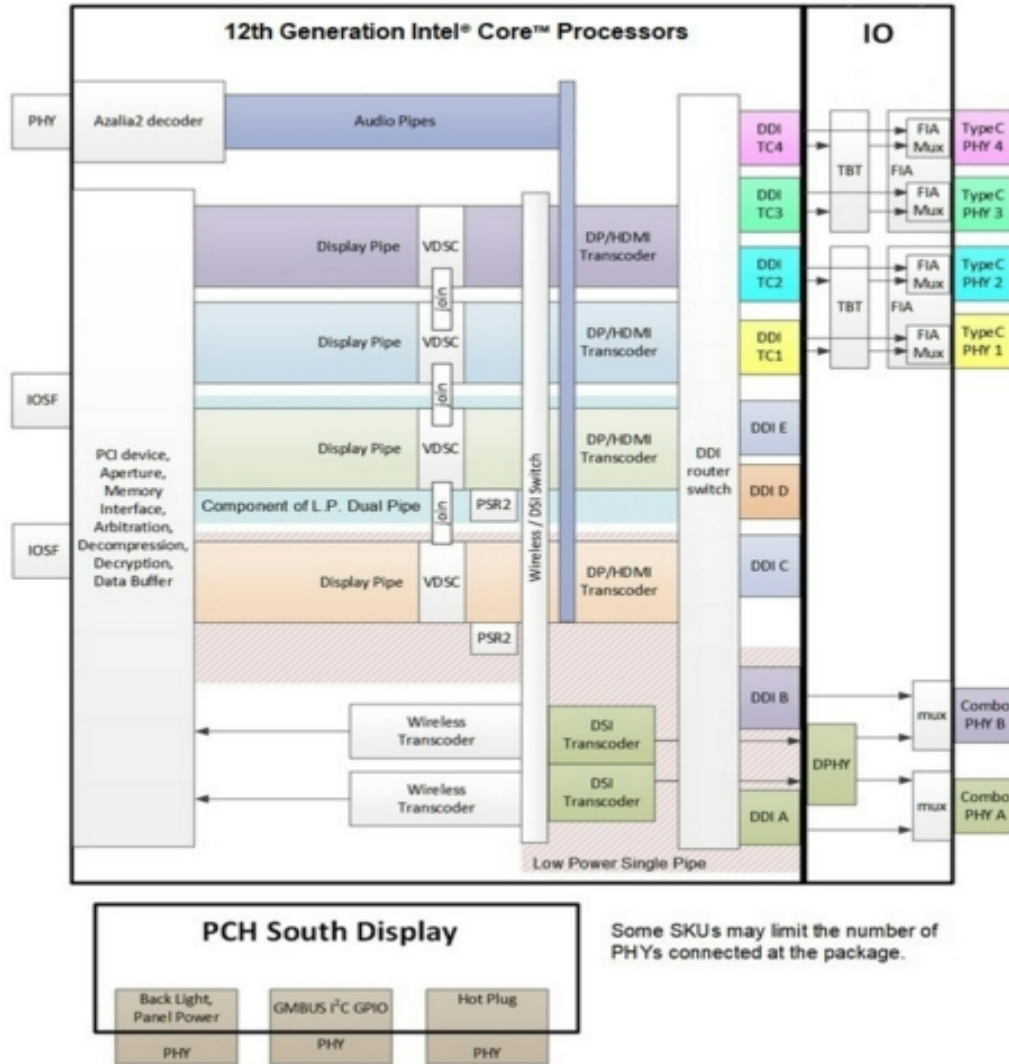

Note: For port availability in the processor line, refer to the above table.

Display Features

General Capabilities

- Up to four simultaneous displays.
 - Single 8K60Hz panel, supported by joining two pipes over single port.
 - Up to 4x4K60Hz display concurrent.
- Display interfaces supported:

- DDI interfaces supports DP*, HDMI*, DVI*, eDP*, DSI*
- TCP interfaces supports DP*, HDMI*, DVI*, Display Alt Mode over Type-C and Display tunneled.
- Up to two wireless display captures.
- Audio stream support on external ports.
- HDR (High Dynamic Range) support.
- Four Display Pipes - Supporting blending, color adjustments, scaling and dithering.
- Transcoders - Containing the Timing generators supporting eDP*, DP*, HDMI* interfaces.
- Up to two Low Power optimized pipes supporting Embedded DisplayPort* and/or MIPI* DSI.
 - LACE (Localized Adaptive Contrast Enhancement), supported up to 5 K resolutions.
 - 3D LUT - power efficient pixel modification function for color processing.
 - FBC (Frame Buffer Compression) - power saving feature.

Multiple Display Configurations

The following multiple display configuration modes are supported (with appropriate driver software):

- Single Display is a mode with one display port activated to display the output to one display device.
- Display Clone is a mode with up to four display ports activated to drive the display content of same color depth setting but potentially different refresh rate and resolution settings to all the active display devices connected.
- Extended Desktop is a mode with up to four display ports activated to drive the content with potentially different color depth, refresh rate, and resolution settings on each of the active display devices connected.

High-bandwidth Digital Content Protection (HDCP)

HDCP is the technology for protecting high-definition content against unauthorized copy or unreceptive between a source (computer, digital set top boxes, and so on) and the sink (panels, monitor, and TVs). The processor supports both HDCP 2.3 and 1.4 content protection over wired displays (HDMI* and DisplayPort*).

The HDCP 1.4, 2.3 keys are integrated into the processor.

DisplayPort*

The DisplayPort* is a digital communication interface that uses differential signaling to achieve a high-bandwidth bus interface designed to support connections between PCs and monitors, projectors, and TV displays.

A DisplayPort* consists of a Main Link (four lanes), Auxiliary channel, and a Hot-Plug Detect signal. The Main Link is a unidirectional, high-bandwidth, and low-latency channel used for transport of isochronous data streams such as uncompressed video and audio. The Auxiliary Channel (AUX CH) is a half-duplex bi-directional channel used for link management and device control. The Hot-Plug Detect (HPD) signal serves as an interrupt request from the sink device to the source device.

The processor is designed in accordance with VESA* DisplayPort* specification. Refer to [Display Technologies Support](#).

DisplayPort* Overview

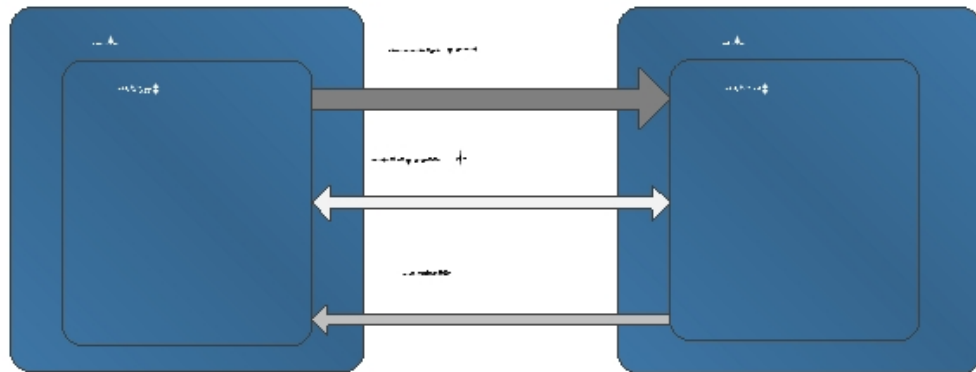

- Support main link of 1, 2, or 4 data lanes.
- Link rate support up to HBR3.
- Aux channel for Link/Device management.
- Hot Plug Detect.
- Support up to 36 BPP (Bit Per Pixel).
- Support SSC.
- Support YCbCR 4:4:4, YCbCR 4:2:0, YCbCR 4:2:2, and RGB color format.
- Support MST (Multi-Stream Transport).
- Support VESA DSC 1.1.
- Adaptive Sync.

Multi-Stream Transport (MST)

- The processor supports Multi-Stream Transport (MST), enabling multiple monitors to be used via a single DisplayPort connector.
- Maximum MST DP supported resolution:

Display Resolutions and Link Bandwidth for Multi-Stream Transport Calculations

Pixels per Line	Lines	Refresh Rate [Hz]	Pixel Clock [MHz]	Link Bandwidth [Gbps]
1920	1080	60	148.5	4.46
1920	1200	60	154	4.62
2048	1152	60	156.75	4.70
2048	1280	60	174.25	5.23
2048	1536	60	209.25	6.28
2304	1440	60	218.75	6.56
2560	1440	60	241.5	7.25
3840	2160	30	262.75	7.88
2560	1600	60	268.5	8.06
2880	1800	60	337.5	10.13
3200	2400	60	497.75	14.93
3840	2160	60	533.25	16.00
4096	2160	60	556.75	16.70
4096	2304	60	605	18.15

Pixels per Line	Lines	Refresh Rate [Hz]	Pixel Clock [MHz]	Link Bandwidth [Gbps]
5120	3200	60	1042.5	31.28

Notes:

1. All the above is related to bit depth of 24.
 2. The data rate for a given video mode can be calculated as- Data Rate = Pixel Frequency * Bit Depth.
 3. The bandwidth requirements for a given video mode can be calculated as: Bandwidth = Data Rate * 1.25 (for 8b/10b coding overhead).
 4. The link bandwidth depends if the standards is reduced blanking or not.
If the standard is not reduced blanking - the expected bandwidth may be higher.
For more details, refer to VESA and Industry Standards and Guidelines for Computer Display Monitor Timing (DMT). Version 1.0, Rev. 13 February 8, 2013
 5. To calculate what are the resolutions that can be supported in MST configurations, follow the below guidelines:
 - a. Identify what is the link bandwidth column according to the requested display resolution.
 - b. Summarize the bandwidth for two of three displays accordingly, and make sure the final result is below 21.6 Gbps. (for example: 4 lanes HBR2 bit rate)
- For example:
- a. Docking two displays: $3840 \times 2160 @ 60 \text{ Hz} + 1920 \times 1200 @ 60 \text{ Hz} = 16 + 4.62 = 20.62 \text{ Gbps}$ [Supported]
 - b. Docking three displays: $3840 \times 2160 @ 30 \text{ Hz} + 3840 \times 2160 @ 30 \text{ Hz} + 1920 \times 1080 @ 60 \text{ Hz} = 7.88 + 7.88 + 4.16 = 19.92 \text{ Gbps}$ [Supported].

DisplayPort Maximum Resolution

Standard	S-Processor Line	H/P-Processor Line	U-Processor Line

Standard	S-Processor Line	H/P-Processor Line	U-Processor Line
DP*	4096x2304 60 Hz 36 bpp	4096x2304 60Hz 36bpp	4096x2304 60Hz 36bpp
	5120x3200 60 Hz 24 bpp	5120x3200 60Hz 24bpp	5120x3200 60Hz 24bpp
DP* with DSC ⁴	5120x3200 120 Hz 30 bpp	5120x3200 120Hz 30bpp	5120x3200 120Hz 30bpp
	7680x4320 60 Hz 30 bpp	7680x4320 60Hz 30bpp	7680x4320 60Hz 30bpp

Notes:

1. Maximum resolution is based on the implementation of 4 lanes at HBR3 link data rate.
2. bpp - bit per pixel.
3. Resolution support is subject to memory BW availability.
4. Resolutions will consume two display pipes.

High-Definition Multimedia Interface (HDMI*)

The High-Definition Multimedia Interface (HDMI*) is provided for transmitting uncompressed digital audio and video signals from DVD players, set-top boxes, and other audio-visual sources to television sets, projectors, and other video displays. It can carry high-quality multi-channel audio data and all standard and high-definition consumer electronics video formats. The HDMI display interface connecting the processor and display devices uses transition minimized differential signaling (TMDS) to carry audiovisual information through the same HDMI cable.

HDMI* includes three separate communications channels: TMDS, DDC, and the optional CEC (consumer electronics control). CEC is not supported on the processor. As shown in the following figure, the HDMI* cable carries four differential pairs that make up the TMDS data and clock channels. These channels are used to carry video, audio, and auxiliary data. In addition, HDMI carries a VESA DDC. The DDC is used by an HDMI* Source to determine the capabilities and characteristics of the Sink.

Audio, video, and auxiliary (control/status) data is transmitted across the three TMDS data channels. The video pixel clock is transmitted on the TMDS clock channel and is used by the receiver for data recovery on the three data channels. The digital display data signals driven natively through the PCH are AC coupled and needs level shifting to convert the AC coupled

signals to the HDMI* compliant digital signals. The processor HDMI* interface is designed in accordance with the High-Definition Multimedia Interface.

HDMI* Overview

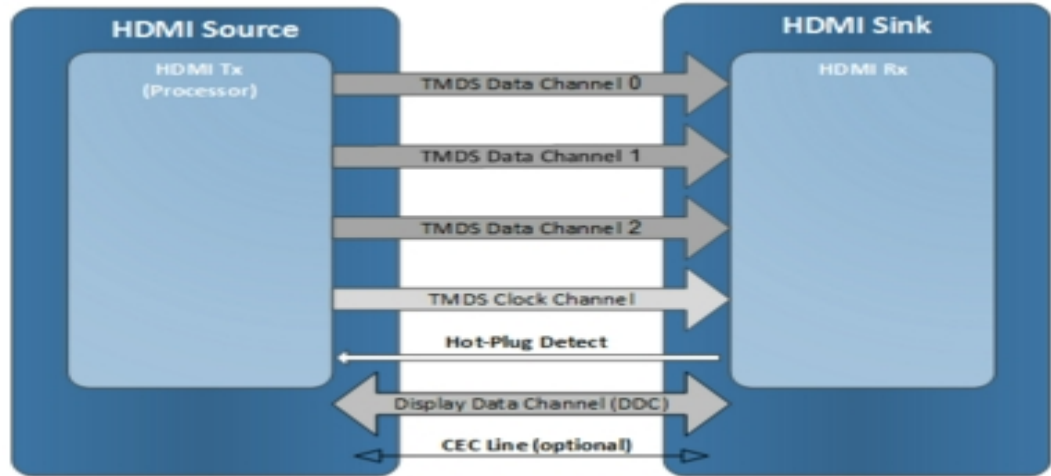

- DDC (Display Data Channel) channel.
- Support YCbCR 4:4:4, YCbCR 4:2:0, YCbCR 4:2:2, and RGB color format.
- Support up to 36 BPP (Bit Per Pixel).
- Hot Plug Detect.

HDMI Maximum Resolution

Standard	S-Processor Line	H/P-Processor Line	U-Processor Line
HDMI 1.4	4Kx2K 24-30 Hz 24 bpp	4Kx2K 24-30 Hz 24bpp	4Kx2K 24-30 Hz 24bpp
HDMI 2.1 TMDS Compatible	4Kx2K 48-60 Hz 24 bpp (RGB/YUV444)	4Kx2K 48-60Hz 24bpp (RGB/YUV444)	4Kx2K 48-60Hz 24bpp (RGB/YUV444)
	4Kx2K 48-60 Hz 12 bpc (YUV420)	4Kx2K 48-60Hz 12bpc (YUV420)	4Kx2K 48-60Hz 12bpc (YUV420)

Standard	S-Processor Line	H/P-Processor Line	U-Processor Line
Notes: <ol style="list-style-type: none"> 1. bpp - bit per pixel. 2. Resolution support is subject to memory BW availability. 3. HDMI2.1 can be supported using PCON (DP1.4 to HDMI2.1 protocol converter). 			

embedded DisplayPort* (eDP*)

The embedded DisplayPort* (eDP*) is an embedded version of the DisplayPort standard oriented towards applications such as notebook and All-In-One PCs. Like DisplayPort, embedded DisplayPort* also consists of the Main Link, Auxiliary channel, and an optional Hot-Plug Detect signal.

- Supported on Low power optimized pipes.
- Support up to HBR3 link rate.
- Support Backlight PWM control and enable signals, and power enable.
- Support VESA DSC 1.1.
- Support SSC.
- Panel Self Refresh 1.
- Panel Self Refresh 2 (supported on P/H/U processor lines).
- MSO 2x2 (Multi Segment Operation).
- Dedicated Aux channel.
- Adaptive Sync.

Embedded DisplayPort Maximum Resolution

Standard	S/HX-Processor Line ¹	H/P-Processor Line	U-Processor Line
eDP*	4096x2304 60 Hz 36 bpp	4096x2304 60Hz 36bpp	4096x2304 60Hz 36bpp
	5120x3200 60 Hz 24 bpp	5120x3200 60Hz 24bpp	5120x3200 60Hz 24bpp

Standard	S/HX-Processor Line ¹	H/P-Processor Line	U-Processor Line
eDP* with DSC ⁵	5120x3200 120 Hz 30 bpp	5120x3200 120Hz 30bpp	5120x3200 120Hz 30bpp

Notes:

1. Maximum resolution is based on the implementation of 4 lanes at HBR3 link data rate.
2. PSR2 supported for H/P/U processor lines only and up to 5 K resolutions.
3. bpp - bit per pixel.
4. Resolution support is subject to memory BW availability.
5. High resolution panels supporting Display Stream Compression (DSC) are supported, technology enablement may be limited due to low market availability.

MIPI* DSI

Display Serial Interface (DSI*) specifies the interface between a host processor and peripherals such as a display module. DSI is a high speed and high performance serial interface that offers efficient and low power connectivity between the processor and the display module.

- One link x8 data lanes or two links each with x4 lanes support.
- Supported on Low power optimized pipes.
- Support Backlight PWM control and enable signals, and power enable.
- Support VESA DSC (Data Stream Compression).

MIPI* DSI Overview

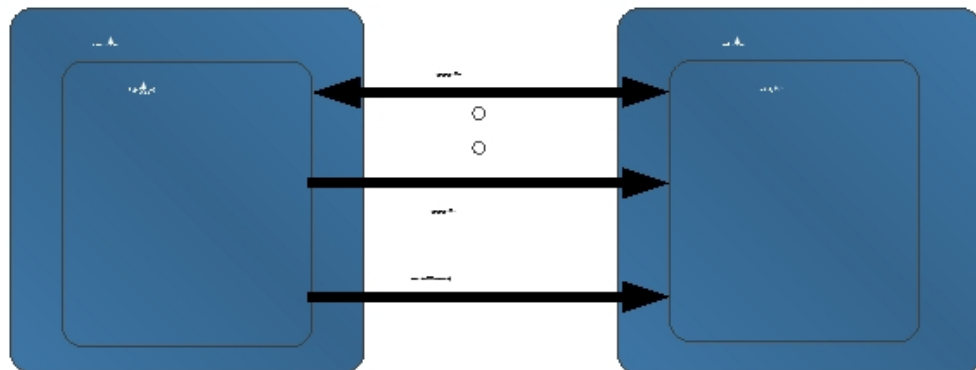

MIPI* DSI Maximum Resolution

Standard	S-Processor Line	H/P-Processor Line	U-Processor Line
MIPI* DSI (Single Link)	N/A	3200x2000 @60 Hz 24 bpp	3200x2000 @60 Hz 24 bpp
MIPI* DSI (Single Link) with DSC	N/A	5120x3200 @60 Hz 24 bpp	5120x3200 @60 Hz 24 bpp
MIPI* DSI (Dual Link)	N/A	4096x2304 @60 Hz 24 bpp 3840x2160 @60 Hz 24 bpp	4096x2304 @60 Hz 24 bpp 3840x2160 @60 Hz 24 bpp
MIPI* DSI (Dual Link) with DSC	N/A	5120x3200 @60 Hz 24 bpp	5120x3200 @60 Hz 24 bpp

Notes:

1. MIPI DSI is available on H/P/U Processor Lines only.
2. bpp - bit per pixel.
3. Resolution support is subject to memory BW availability.

Integrated Audio

- HDMI* and DisplayPort interfaces can carry audio along with video.
- The processor supports three High Definition audio streams on four digital ports simultaneously (the DMA controllers are in PCH).
- The integrated audio processing (DSP) is performed by the PCH and delivered to the processor using the AUDIO_SDI and AUDIO_CLK inputs pins.
- The AUDIO_SDO output pin is used to carry responses back to the PCH.
- Supports only the internal HDMI and DP CODECs.

Processor Supported Audio Formats over HDMI* and DisplayPort*

Audio Formats	HDMI*	DisplayPort*
AC-3 Dolby* Digital	Yes	Yes
Dolby* Digital Plus	Yes	Yes
DTS-HD*	Yes	Yes
LPCM, 192 kHz/24 bit, 6 Channel	Yes	Yes
Dolby* TrueHD, DTS-HD Master Audio* (Lossless Blu-Ray Disc* Audio Format)	Yes	Yes

The processor will continue to support Silent stream. A Silent stream is an integrated audio feature that enables short audio streams, such as system events to be heard over the HDMI* and DisplayPort* monitors. The processor supports silent streams over the HDMI and DisplayPort interfaces at 44.1 kHz, 48 kHz, 88.2 kHz, 96 kHz, 176.4 kHz, and 192 kHz sampling rates and silent multi-stream support.

Camera/MIPI

Camera/MIPI is supported on the following processor line.

- P-Processor line
- H-Processor line
- U-Processor line

Note: The availability of the features above may vary between different processor SKUs.

Camera Pipe Support

The IPU6se fixed function pipe supports the following functions:

- Black level correction;
- White balance;
- Color matching;
- Lens shading (vignette) correction;
- Color crosstalk (color shading) correction;

- Dynamic defect pixel replacement;
- Auto-focus-pixel (PDAF) hiding;
- High quality demosaic;
- Scaling and format conversion;
- Temporal noise reduction running on Intel graphics.

MIPI* CSI-2 Camera Interconnect

The Camera I/O Controller provides a native/integrated interconnect to camera sensors, compliant with MIPI* CSI-2 V2.0 protocol. Total of 8 data+4 clock lanes are available for the camera interface supporting up to 4 sensors .

Data transmission interface (referred as CSI-2) is a unidirectional differential serial interface with data and clock signals; the physical layer of this interface is the MIPI* Alliance Specification for D-PHY.

The control interface (referred as CCI) is a bi-directional control interface compatible with I²C standard.

Camera Control Logic

The camera infrastructure supports several architectural options for camera control utilizing camera PMIC and/or discrete logic. IPU6 control options utilize I²C for bidirectional communication and PCH GPIOs to drive various control functions.

Camera Modules

Intel maintains an Intel User Facing Camera Approved Vendor List and Intel World-Facing Approved Vendor List to simplify system design. Additional services are available to support non-AVL options.

CSI-2 Lane Configuration

CSI-2 Lane Configuration for H/P/U-Processor Lines

Port Data/Clock	Configuration Option 1	Configuration Option 2
Port A Clock	NA	
Port A Lane 0	x4	x2

Port Data/Clock	Configuration Option 1	Configuration Option 2	
Port A Lane 1			
Port B Clock			
Port B Lane 0			x2
Port B Lane 1			
Port C Clock	x4	x2	
Port C Lane 0			
Port C Lane 1			
Port D Lane 0		x2	
Port D Lane 1			
Port D Clock	NA		

Signal Description

This chapter describes the processor signals. They are arranged in functional groups according to their associated interface or category. The notations in the following table are used to describe the signal type.

The signal description also includes the type of buffer used for the particular signal (refer to the following table).

Signal Tables Terminology

Notation	Signal Type
----------	-------------

Notation	Signal Type
I	Input pin
O	Output pin
I/O	Input/Output, Bi-directional pin
SE	Single Ended Link
Diff	Differential Link
CMOS	CMOS buffers. 1.05 V- tolerant
OD	Open Drain buffer
LPDDR4x	LPDDR4x buffers: 1.1 V-tolerant
LPDDR5	LPDDR5 buffers
DDR4	DDR4 buffers: 1.2 V-tolerant
DDR5	DDR5 buffers: 1.1 V-tolerant
A	Analog reference or output. May be used as a threshold voltage or for buffer compensation
GTL	Gunning Transceiver Logic signaling technology
Ref	Voltage Reference signal

Notation	Signal Type
Availability	Signal Availability condition - based on segment, SKU, platform type or any other factor
Asynchronous 1	Signal has no timing relationship with any reference clock.
<p>Note: Qualifier for a buffer type.</p>	

System Memory Interface

DDR4 Memory Interface

DDR4 Memory Interface

Signal Name	Description	Dir.	Buffer Type	Link Type	Availability
-------------	-------------	------	-------------	-----------	--------------



Signal Name	Description	Dir.	Buffer Type	Link Type	Availability
DDR0_ DQ0[7:0]	<p>Data Buses: Data signals interface to the SDRAM data buses.</p> <p>Example: DDR0_ DQ2[5] refers to DDR channel 0, Byte 2, Bit 5.</p>	I/O	DDR4	SE	S Processor Line P Processor Line H Processor Line U15 Processor
DDR0_ DQ1[7:0]					
DDR0_ DQ2[7:0]					
DDR0_ DQ3[7:0]					
DDR0_ DQ4[7:0]					
DDR0_ DQ5[7:0]					
DDR0_ DQ6[7:0]					
DDR0_ DQ7[7:0]					
DDR0_ DQ8[7:0]					
DDR1_ DQ0[7:0]					
DDR1_ DQ1[7:0]					
DDR1_ DQ2[7:0]					
DDR1_ DQ3[7:0]					
DDR1_ DQ4[7:0]					
DDR1_ DQ5[7:0]					
DDR1_ DQ6[7:0]					
DDR1_ DQ7[7:0]					
DDR1_ DQ8[7:0]					

Signal Name	Description	Dir.	Buffer Type	Link Type	Availability
DDR0_ DQSP[8:0] DDR1_ DQSP[8:0] DDR0_ DQSN[8:0] DDR1_ DQSN[8:0]	<p>Data Strobes: Differential data strobe pairs. The data is captured at the crossing point of DQS during reading and write transactions.</p> <p>Example: DDR0_ DQSP0 refers to DQSP of DDR channel 0, Byte 0.</p>	I/O	DDR4	Diff	S Processor Line P Processor Line H Processor Line U15 Processor
DDR0_ CLKN[3:0] DDR0_ CLKP[3:0] DDR1_ CLKN[3:0] DDR1_ CLKP[3:0]	<p>SDRAM Differential Clock: Differential clocks signal pairs, pair per rank. The crossing of the positive edge and the negative edge of their complement are used to sample the command and control signals on the SDRAM.</p>	O	DDR4	Diff	S Processor Line



Signal Name	Description	Dir.	Buffer Type	Link Type	Availability
DDR0_CLK_N[1:0] DDR0_CLK_P[1:0] DDR1_CLK_N[1:0] DDR1_CLK_P[1:0]	SDRAM Differential Clock: Differential clocks signal pairs, pair per rank. The crossing of the positive edge and the negative edge of their complement are used to sample the command and control signals on the SDRAM.	O	DDR4	Diff	P Processor Line H Processor Line U15 Processor

Signal Name	Description	Dir.	Buffer Type	Link Type	Availability
DDR0_CKE[3:0] DDR1_CKE[3:0]	<p>Clock Enable: (1 per rank). These signals are used to:</p> <ul style="list-style-type: none"> Initialize the SDRAMs during power-up. Power-down SDRAM ranks. Place all SDRAM ranks into and out of self-refresh during STR (Suspend to RAM). 	O	DDR4	SE	S Processor Line P Processor Line H Processor Line U15 Processor
DDR0_CS[3:0] DDR1_CS[3:0]	<p>Chip Select: (1 per rank). These signals are used to select particular SDRAM components during the active state. There is one Chip Select for each SDRAM rank.</p>	O	DDR4	SE	S Processor Line P Processor Line H Processor Line U15 Processor

Signal Name	Description	Dir.	Buffer Type	Link Type	Availability
DDR0_ ODT[3:0] DDR1_ ODT[3:0]	On Die Termination: (1 per rank). Active SDRAM Termination Control.	O	DDR4	SE	S Processor Line P Processor Line H Processor Line U15 Processor

Signal Name	Description	Dir.	Buffer Type	Link Type	Availability
DDR0_ MA[16:0] DDR1_ MA[16:0]	<p>Address: These signals are used to provide the multiplexed row and column address to the SDRAM.</p> <p>DDR0_ MA[16] uses as RAS# signal</p> <p>DDR0_ MA[15] uses as CAS# signal</p> <p>DDR0_ MA[14] uses as WE# signal</p> <p>DDR1_ MA[16] uses as RAS# signal</p> <p>DDR1_ MA[15] uses as CAS# signal</p> <p>DDR1_ MA[14] uses as WE# signal</p>	O	DDR4	SE	S Processor Line P Processor Line H Processor Line U15 Processor

Signal Name	Description	Dir.	Buffer Type	Link Type	Availability
DDR0_ACT# DDR1_ACT#	<p>Activation Command: ACT# HIGH along with CS_N determines that the signals addresses below have command functionality .</p>	O	DDR4	SE	<p>S Processor Line</p> <p>P Processor Line</p> <p>H Processor Line</p> <p>U15 Processor</p>
DDR0_BG[1:0] DDR1_BG[1:0]	<p>Bank Group: BG[1:0] define to which bank group an Active, reading, Write or Precharge command is being applied.</p> <p>BG0 also determines which mode register is to be accessed during a MRS cycle.</p>	O	DDR4	SE	<p>S Processor Line</p> <p>P Processor Line</p> <p>H Processor Line</p> <p>U15 Processor</p>

Signal Name	Description	Dir.	Buffer Type	Link Type	Availability
DDR0_ BA[1:0] DDR1_ BA[1:0]	Bank Address: BA[1:0] define to which bank an Active, reading, Write or Precharge command is being applied. Bank address also determines which mode register is to be accessed during a MRS cycle.	O	DDR4	SE	S Processor Line P Processor Line H Processor Line U15 Processor
DDR0_PAR DDR1_PAR	Command and Address Parity: These signals are used for parity check.	O	A	SE	S Processor Line P Processor Line H Processor Line U15 Processor
DDR_VREF_ CA[3:0]	Memory Reference Voltage for Command and Address	O	A	SE	S Processor Line

Signal Name	Description	Dir.	Buffer Type	Link Type	Availability
DDR0_VREF_CA0 DDR1_VREF_CA0	Memory Reference Voltage for Command and Address	O	A	SE	P Processor Line H Processor Line U15 Processor
DDR_VTT_CTL	System Memory Power Gate Control: When signal is high – platform memory VTT regulator is enable, output high. When signal is low - Disables the platform memory VTT regulator in C8 and deeper and S3.	O	A	SE	S Processor Line P Processor Line H Processor Line U15 Processor

Signal Name	Description	Dir.	Buffer Type	Link Type	Availability
DDR0_ALERT# DDR1_ALERT#	Alert: This signal is used at command training only. It is getting the Command and Address Parity error flag during training. CRC feature is not supported.	I	DDR4	SE	S Processor Line P Processor Line H Processor Line U15 Processor

LP4x-LP5 Memory Interface

Signal Name	Description	Dir.	Buffer Type	Link Type	Availability
DDR0_DQ[1:0] [7:0] DDR1_DQ[1:0] [7:0] DDR2_DQ[1:0] [7:0] DDR3_DQ[1:0] [7:0] DDR4_DQ[1:0] [7:0] DDR5_DQ[1:0] [7:0] DDR6_DQ[1:0] [7:0] DDR7_DQ[1:0] [7:0]	Data Buses: Data signals interface to the SDRAM data buses. Example: DDR0_DQ1[5] refers to DDR channel 0, Byte 1, Bit 5.	I/O	LP4x-LP5	SE	P Processor Line U Processor Line H Processor Line

Signal Name	Description	Dir.	Buffer Type	Link Type	Availability
DDR0_DQSP[1:0]	Data Strobes: Differential data strobe pairs. The data is captured at the crossing point of DQS during reading and write transactions.	I/O	LP4x-LP5	Diff	P Processor Line U Processor Line H Processor Line
DDR1_DQSP[1:0]					
DDR2_DQSP[1:0]					
DDR3_DQSP[1:0]					
DDR4_DQSP[1:0]					
DDR5_DQSP[1:0]					
DDR6_DQSP[1:0]					
DDR7_DQSP[1:0]					
DDR0_DQSN[1:0]					
DDR1_DQSN[1:0]					
DDR2_DQSN[1:0]					
DDR3_DQSN[1:0]					
DDR4_DQSN[1:0]					
DDR5_DQSN[1:0]					
DDR6_DQSN[1:0]					
DDR7_DQSN[1:0]					

Signal Name	Description	Dir.	Buffer Type	Link Type	Availability
DDR0_CLK_N DDR0_CLK_P DDR1_CLK_N DDR1_CLK_P DDR2_CLK_N DDR2_CLK_P DDR3_CLK_N DDR3_CLK_P DDR4_CLK_N DDR4_CLK_P DDR5_CLK_N DDR5_CLK_P DDR6_CLK_N DDR6_CLK_P DDR7_CLK_N DDR7_CLK_P	<p>SDRAM Differential Clock:</p> <p>Differential clocks signal pairs, pair per channel and package. The crossing of the positive edge and the negative edge of their complement are used to sample the command and control signals on the SDRAM.</p>	O	LP4x-LP5	Diff	P Processor Line U Processor Line H Processor Line
DDR0_CKE[1:0] DDR1_CKE[1:0] DDR2_CKE[1:0] DDR3_CKE[1:0] DDR4_CKE[1:0] DDR5_CKE[1:0] DDR6_CKE[1:0] DDR7_CKE[1:0]	<p>Clock Enable: (1 per rank) These signals are used to:</p> <ul style="list-style-type: none"> Initialize the SDRAMs during power-up. Power-down SDRAM ranks. Place all SDRAM ranks into and out of self-refresh during STR. 	O	LP4x-LP5	SE	P Processor Line U Processor Line H Processor Line

Signal Name	Description	Dir.	Buffer Type	Link Type	Availability
DDR0_CS[1:0] DDR1_CS[1:0] DDR2_CS[1:0] DDR3_CS[1:0] DDR4_CS[1:0] DDR5_CS[1:0] DDR6_CS[1:0] DDR7_CS[1:0]	<p>Chip Select: (1 per rank). These signals are used to select particular SDRAM components during the active state. There is one Chip Select for each SDRAM rank.</p> <p>The Chip select signal is Active High.</p>	O	LP4x-LP5	SE	P Processor Line U Processor Line H Processor Line
DDR0_CA[5:0] DDR1_CA[5:0] DDR2_CA[5:0] DDR3_CA[5:0] DDR4_CA[5:0] DDR5_CA[5:0] DDR6_CA[5:0] DDR7_CA[5:0]	<p>Command Address: These signals are used to provide the multiplexed command and address to the SDRAM.</p>	O	LP4x-LP5	SE	P Processor Line U Processor Line H Processor Line
DDR0_CA[6] DDR1_CA[6] DDR2_CA[6] DDR3_CA[6] DDR4_CA[6] DDR5_CA[6] DDR6_CA[6] DDR7_CA[6]	<p>Command Address: These signals are used to provide the multiplexed command and address to the SDRAM.</p>	O	LP5	SE	P Processor Line U Processor Line H Processor Line

Signal Name	Description	Dir.	Buffer Type	Link Type	Availability
DDR[7:0]_WCK_P DDR[7:0]_WCK_N	Write Clocks: WCK_N and WCK_P are differential clocks used for WRITE data capture and READ data output.	O	LP5	Diff	P Processor Line U Processor Line H Processor Line
DDR_COMP DDR_RCOMP	System Memory Resistance Compensation	A	A	SE	P Processor Line U Processor Line H Processor Line
DRAM_RESET#	Memory Reset	O	CMOS	SE	P Processor Line U Processor Line H Processor Line

DDR5 Memory Interface

DDR5 Memory Interface

Signal Name	Description	Dir.	Buffer Type	Link Type	Availability
-------------	-------------	------	-------------	-----------	--------------

Signal Name	Description	Dir.	Buffer Type	Link Type	Availability
DDR0_DQ0[7:0] DDR0_DQ1[7:0] DDR0_DQ2[7:0] DDR0_DQ3[7:0] DDR0_DQ4[7:0] DDR1_DQ0[7:0] DDR1_DQ1[7:0] DDR1_DQ2[7:0] DDR1_DQ3[7:0] DDR1_DQ4[7:0] DDR2_DQ0[7:0] DDR2_DQ1[7:0] DDR2_DQ2[7:0] DDR2_DQ3[7:0] DDR2_DQ4[3:0] DDR3_DQ0[7:0] DDR3_DQ1[7:0] DDR3_DQ2[7:0] DDR3_DQ3[7:0] DDR3_DQ4[3:0]	<p>Data Buses: Data signals interface to the SDRAM data buses.</p> <p>Example: DDR0_DQ2[5] refers to DDR channel 0, Byte 2, Bit 5.</p>	I/O	DDR 5	SE	S Processor Line P Processor Line
DDR0_DQSP[4:0] DDR0_DQSN[4:0] DDR1_DQSP[4:0] DDR1_DQSN[4:0] DDR2_DQSP[4:0] DDR2_DQSN[4:0] DDR3_DQSP[4:0] DDR3_DQSN[4:0]	<p>Data Strobes: Differential data strobe pairs. The data is captured at the crossing point of DQS during reading and write transactions.</p> <p>Example: DDR0_DQSP0 refers to DQSP of DDR channel 0, Byte 0.</p>	I/O	DDR 5	Dif f	S Processor Line P Processor Line

Signal Name	Description	Dir.	Buffer Type	Link Type	Availability
DDR0_CLKN[3:0] DDR0_CLKP[3:0] DDR1_CLKN[3:0] DDR1_CLKP[3:0] DDR2_CLKN[3:0] DDR2_CLKP[3:0] DDR3_CLKN[3:0] DDR3_CLKP[3:0]	SDRAM Differential Clock: Differential clocks signal pairs, pair per rank. The crossing of the positive edge and the negative edge of their complement are used to sample the command and control signals on the SDRAM.	O	DDR 5	Dif f	S Processor Line
DDR0_CLK_N[1:0] DDR0_CLK_P[1:0] DDR1_CLK_N[1:0] DDR1_CLK_P[1:0] DDR2_CLK_N[1:0] DDR2_CLK_P[1:0] DDR3_CLK_N[1:0] DDR3_CLK_P[1:0]	SDRAM Differential Clock: Differential clocks signal pairs, pair per rank. The crossing of the positive edge and the negative edge of their complement are used to sample the command and control signals on the SDRAM.	O	DDR 5	Dif f	P Processor Line
DDR0_CS[3:0] DDR1_CS[3:0] DDR2_CS[3:0] DDR3_CS[3:0]	Chip Select: (1 per rank). These signals are used to select particular SDRAM components during the active state. There is one Chip Select for each SDRAM rank. The Chip select signal is Active High.	O	DDR 5	SE	S Processor Line P Processor Line
DDR0_CA[12:0] DDR1_CA[12:0] DDR2_CA[12:0] DDR3_CA[12:0]	Command Address: These signals are used to provide the multiplexed command and address to the SDRAM.	O	DDR 5	SE	S Processor Line P Processor Line

Signal Name	Description	Dir.	Buffer Type	Link Type	Availability
DDR_VREF_CA[3:0]	Memory Reference Voltage for Command and Address	O	A	SE	S Processor Line
DDR0_ALERT# DDR1_ALERT#	Alert: This signal is used at command training only. It is getting the Command and Address Parity error flag during training. CRC feature is not supported.	I	DDR 5	SE	S Processor Line P Processor Line

PCI Express* Graphics (PEG) Signals

Signal Name	Description	Dir	Buffer Type	Link Type	Availability
PCIE_X4_TXP[[3:0]] PCIE_X4_TXN[[3:0]]	PCIe Transmit Differential Pairs	O	PCIE*	Diff	S/HX Processor Line
PCIE_X4_RXP[[3:0]] PCIE_X4_RXN[[3:0]]	PCIe Receive Differential Pairs	I	PCIE*	Diff	S/HX Processor Line
PCIE_X16_TXP[[15:0]] PCIE_X16_TXN[[15:0]]	PCIe Transmit Differential Pairs	O	PCIE*	Diff	S/HX Processor Line

Signal Name	Description	Dir	Buffer Type	Link Type	Availability
PCIE_X16_RXP[[15:0]] PCIE_X16_RXN[[15:0]]	PCIe Receive Differential Pairs	I	PCIE*	Diff	S/HX Processor Line
PCIEX4_A_TX_P[[3:0]] PCIEX4_A_TX_N[[3:0]]	PCIe Transmit Differential Pairs	O	PCIE*	Diff	P Processor Line U Processor Line H Processor Line
PCIEX4_B_TXP[[3:0]] PCIEX4_B_TXN[[3:0]]	PCIe Transmit Differential Pairs	O	PCIE*	Diff	P Processor Line
PCIEX4_A_RX_P[[3:0]] PCIEX4_A_RX_N[[3:0]]	PCIe Receive Differential Pairs	I	PCIE*	Diff	P Processor Line U Processor Line H Processor Line
PCIEX4_B_RXP[[3:0]] PCIEX4_B_RXN[[3:0]]	PCIe Receive Differential Pairs	I	PCIE*	Diff	P Processor Line
PCIEX4_A_RCOMP_P PCIEX4_A_RCOMP_N	Resistance Compensation	N A	A	Diff	P Processor Line U Processor Line H Processor Line
PCIEX4_A_RCOMP_P PCIEX4_A_RCOMP_N	Resistance Compensation	N A	A	Diff	U9 Processor Line

Signal Name	Description	Dir	Buffer Type	Link Type	Availability
PCIEX4_B_RCOMP_P PCIEX4_B_RCOMP_N	Resistance Compensation	N A	A	Diff	P Processor Line H Processor Line U15 Processor Line
PCIEX8_TX_P[[7:0]] PCIEX8_TX_N[[7:0]]	PCIe Transmit Differential Pairs	O	PCIE*	Diff	H Processor Line
PCIEX8_RX_P[[7:0]] PCIEX8_RX_N[[7:0]]	PCIe Receive Differential Pairs	I	PCIE*	Diff	H Processor Line
PCIEX8_RCOMP_P PCIEX8_RCOMP_N	Resistance Compensation	N A	A	Diff	H Processor Line

Direct Media Interface (DMI) Signals

Signal Name	Description	Dir	Buffer Type	Link Type	Availability
DMI_RXP[7:0] DMI_RXN[7:0]	DMI Input from PCH: Direct Media Interface receive differential pairs.	I	DMI	Diff	S/HX-Processor Line
DMI_TXP[7:0] DMI_TXN[7:0]	DMI Output from PCH: Direct Media Interface transmit differential pairs.	O	DMI	Diff	

Reset and Miscellaneous Signals

Signal Name	Description	Dir.	Buffer Type	Link Type	Availability
EKEY	<p>Socket Electronic Key</p> <p>Used to distinguish between packages with different pins assignment. Connect this pin to the Enable signal of the first VR in sequence. Or as appropriate, to shut down complete power to SOC/platform when a wrong package is being used.</p>	NA	NA	SE	S-Processor Line
SKTOCC#	<p>Socket Occupied: Pulled down directly (0 Ohms) on the processor package to the ground. There is no connection to the processor silicon for this signal. System board designers may use this signal to determine if the processor is present.</p>	NA	NA	SE	S-Processor Line H-Processor Line P-Processor Line U-Processor Line



Signal Name	Description	Dir.	Buffer Type	Link Type	Availability
CFG[17:0]	<p>Configuration Signals: The CFG signals have a default value of '1' if not terminated on the board.</p> <p>Intel recommends placing test points on the board for CFG pins.</p> <ul style="list-style-type: none"> • CFG[1:0]: Reserved configuration lane. • CFG[2]: S-Processor Line PCI Express* Static x16 Lanes Numbering Reversal • CFG[2]: H-Processor Line PCI Express* Static x8 Lanes Numbering Reversal • CFG[2]: U9-Processor Line Reserved • CFG[3]: Reserved configuration lane. • CFG[4]: Reserved • CFG[5] S-Processor Line PCI Express* Bifurcation <ul style="list-style-type: none"> ◦ 0 = 2 x8 PCI Express* ◦ 1 = 1 x16 PCI Express* (default) • CFG[5] H/P/U15-Processor Line Reserved configuration lanes. • CFG[6]: Reserved configuration lanes. • CFG[7]: Reserved configuration lanes. • CFG[13:8]: Reserved configuration lanes. • CFG[14]: S-Processor Line PEG60 Lane Reversal: <ul style="list-style-type: none"> ◦ 1 - (Default) Normal ◦ 0 - Reversed 	I/O	GTL	SE	<p>S-Processor Line</p> <p>H-Processor Line</p> <p>P-Processor Line</p> <p>U-Processor Line</p>

Signal Name	Description	Dir.	Buffer Type	Link Type	Availability
	<ul style="list-style-type: none"> • CFG[14]: H/P/U15-Processor Line PEG60 Lane Reversal: <ul style="list-style-type: none"> ◦ 1 - (Default) Normal ◦ 0 - Reversed • CFG[15]: H/P/U15-Processor Line PEG62 Lane Reversal: <ul style="list-style-type: none"> ◦ 1 - (Default) Normal ◦ 0 - Reversed • CFG[14]: U9 Processor Line PEG60 Lane Reversal: <ul style="list-style-type: none"> ◦ 1 - (Default) Normal ◦ 0 - Reversed • CFG[17:15]: U9 and S-Processor Line Reserved configuration lanes. • CFG[17:16]: H/P/U15-Processor Line Reserved configuration lanes. 				
CFG_RCOMP	Configuration Resistance Compensation	NA	NA	SE	H-Processor Line P-Processor Line U-Processor Line
VCC_CFG_PU_OUT	Power rail used by platform CFG straps for pull up resistors.	O	GTL	SE	S-Processor Line H-Processor Line P-Processor Line

Signal Name	Description	Dir.	Buffer Type	Link Type	Availability
EAR#	<p>Stall reset sequence for early reset phases debug until deasserted:</p> <p>— 1 = (Default) Normal Operation; No stall.</p> <p>— 0 = Stall.</p>	I	CMOS	SE	<p>S-Processor Line</p> <p>H-Processor Line</p> <p>P-Processor Line</p> <p>U-Processor Line</p>
RESET#	Platform Reset pin driven by the PCH.	I	CMOS	SE	S-Processor Line
CPU_ID	A PLATFORM indication signal, for Compatibility option.		CMOS	SE	<p>S-Processor Line</p> <p>H-Processor Line</p> <p>P-Processor Line</p> <p>U-Processor Line</p>
PROC_TRIGIN	Debug pin	I	CMOS	SE	S-Processor Line
PROC_TRIGOUT	Debug pin	O	CMOS	SE	S-Processor Line

Signal Name	Description	Dir.	Buffer Type	Link Type	Availability
DRAM_RESET#	Memory Reset	O	CMOS	SE	H-Processor Line P-Processor Line U-Processor Line

Display Interfaces

Digital Display Interface (DDI) Signals

Signal Name	Description	Dir.	Link Type	Availability
DDIx_TXP[3:0] DDIx_TXN[3:0]	Digital Display Interface Transmitter lanes. DisplayPort, Embedded DisplayPort, HDMI and MIPI DSI Differential Pairs.	O	Diff	S Processor Line P Processor Line H Processor Line U Processor Line
DDIx_AUXP DDIx_AUXN	Digital Display Interface Display Port Auxiliary: Half-duplex, bidirectional channel consist of one differential pair for each channel. MIPI DSI interface differential pair.	I/O	Diff	
DISP_UTILS_1	Digital Display Interface Utility Pin. MIPI DSI Tearing effect signal	O	SE	

Signal Name	Description	Dir.	Link Type	Availability
DISP_UTILS_2	Digital Display Interface Utility Pin. MIPI DSI Tearing effect signal.	O	SE	
DDIA_RCOMP DDIB_RCOMP	DDI IO Compensation resistors. U, P, Px, H processor lines only	A	SE	P Processor Line H Processor Line U Processor Line
<p>Notes:</p> <ul style="list-style-type: none"> eDP*/DP*/HDMI*/DSI* implementation go along with additional sideband signals, for more information refer to Intel® 600 Series Chipset Family Platform Controller Hub • Datasheet, Volume 1 of 2 (#648364). x Can be ports A, B, C, D, E 				

Digital Display Audio Signals

Signal Name	Description	Dir.	Link Type	Availability
PROC_AUDOUT	Serial Data Output for display audio interface	O	SE	S/HX Processor Line
PROC_AUDIN	Serial Data Input for display audio interface	I	SE	
PROC_AUDCLK	Serial Data Clock	I	SE	

USB Type-C Signals

Signal Name	Description	Dir.	Link Type	Availability
TCP[1:0]_TX_P[1:0] TCP[1:0]_TX_N[1:0]	TX Data Lane.	O	Diff	P Processor Line H Processor Line U Processor Line
TCP[3:2]_TX_P[1:0] TCP[3:2]_TX_N[1:0]	TX Data Lane.	O	Diff	P Processor Line H Processor Line U15 Processor Line
TCP[1:0]_TXRX_P[1:0] TCP[1:0]_TXRX_N[1:0]	RX Data Lane, also serves as the secondary TX data lane.	I/O	Diff	P Processor Line H Processor Line U Processor Line
TCP[3:2]_TXRX_P[1:0] TCP[3:2]_TXRX_N[1:0]	RX Data Lane, also serves as the secondary TX data lane.	I/O	Diff	P Processor Line H Processor Line U15 Processor Line
TCP[1:0]_AUX_P TCP[1:0]_AUX_N	Common Lane AUX-PAD.	I/O	Diff	P Processor Line H Processor Line U Processor Line

Signal Name	Description	Dir.	Link Type	Availability
TCP[3:2]_AUX_P TCP[3:2]_AUX_N	Common Lane AUX-PAD.	I/O	Diff	P Processor Line H Processor Line U15 Processor Line
TCPO_RCOMP TCP_RCOMP	Type-C Resistance Compensation.	N/A	Diff	P Processor Line H Processor Line U Processor Line

MIPI* CSI-2 Interface Signals

Signal Name	Description	Dir.	Buffer Type	Link Type	Availability
CSI_A_ DP[1:0] CSI_ A_DN[1:0]	CSI-2 Ports Data lane	I	DPHY	Diff	P Processor Line H Processor Line U Processor Line
CSI_D_ DP[1:0] CSI_ D_DN[1:0]	CSI-2 Ports Data lane	I	DPHY	Diff	P Processor Line H Processor Line U Processor Line

Signal Name	Description	Dir.	Buffer Type	Link Type	Availability
CSI_B_DP[3:0] CSI_B_DN[3:0]	CSI-2 Ports Data lane	I	DPHY	Diff	P Processor Line H Processor Line U Processor Line
CSI_C_DP[3:0] CSI_C_DN[3:0]	CSI-2 Ports Data lane	I	DPHY	Diff	P Processor Line H Processor Line U Processor Line
CSI_A_CLK_P CSI_A_CLK_N	CSI 2 Port A Clock lane	I	DPHY	Diff	P Processor Line H Processor Line U Processor Line
CSI_B_CLK_P CSI_B_CLK_N	CSI 2 Port A Clock lane	I	DPHY	Diff	P Processor Line H Processor Line U Processor Line
CSI_C_CLK_P CSI_C_CLK_N	CSI 2 Port A Clock lane	I	DPHY	Diff	P Processor Line H Processor Line U Processor Line

Signal Name	Description	Dir.	Buffer Type	Link Type	Availability
CSI_D_CLK_P CSI_D_CLK_N	CSI 2 Port A Clock lane	I	DPHY	Diff	P Processor Line H Processor Line U Processor Line
CSI_RCOMP	CSI Resistance Compensation	N/A	N/A	SE	P Processor Line H Processor Line U Processor Line

Processor Clocking Signals

Signal Name	Description	Dir.	Buffer Type	Link Type	Availability
BCLK_P BCLK_N	100 MHz Differential bus clock input to the processor.	I		Diff	
CLK_NSSC_P CLK_NSSC_N	38.4 MHz Differential bus clock input to the processor.	I		Diff	S-Processor Line
PCI_BCLKP PCI_BCLKN	100 MHz Clock for PCI Express* logic	I		Diff	

Testability Signals

Signal Name	Description	Dir.	Buffer Type	Link Type	Availability
BPM#[3:0]	Breakpoint and Performance Monitor Signals: Outputs from the processor that indicate the status of breakpoints and programmable counters used for monitoring processor performance.	I/O	GTL	SE	S Processor Line P Processor Line H Processor Line U Processor Line
PROC_PRDY#	Probe Mode Ready: PROC_PRDY# is a processor output used by debug tools to determine processor debug readiness.	O	OD	SE	S Processor Line P Processor Line H Processor Line U Processor Line
PROC_PREQ#	Probe Mode Request: PROC_PREQ# is used by debug tools to request debug operation of the processor.	I	GTL	SE	S Processor Line P Processor Line H Processor Line U Processor Line
PROC_TCK	Test Clock: This signal provides the clock input for the processor Test Bus (also known as the Test Access Port). This signal should be driven low or allowed to float during power on Reset.	I	GTL	SE	S Processor Line

Signal Name	Description	Dir.	Buffer Type	Link Type	Availability
PROC_TDI	Test Data In: This signal transfers serial test data into the processor. This signal provides the serial input needed for JTAG specification support.	I	GTL	SE	S Processor Line
PROC_TDO	Test Data Out: This signal transfers serial test data out of the processor. This signal provides the serial output needed for JTAG specification support.	O	OD	SE	S Processor Line
PROC_TMS	Test Mode Select: A JTAG specification support signal used by debug tools.	I	GTL	SE	S Processor Line
PROC_JTAG_TCK	Test Clock: This signal provides the clock input for the processor Test Bus (also known as the Test Access Port). This signal should be driven low or allowed to float during power on Reset.	I	GTL	SE	P Processor Line H Processor Line U Processor Line
PROC_JTAG_TDI	Test Data In: This signal transfers serial test data into the processor. This signal provides the serial input needed for JTAG specification support.	I	GTL	SE	P Processor Line H Processor Line U Processor Line
PROC_JTAG_TDO	Test Data Out: This signal transfers serial test data out of the processor. This signal provides the serial output needed for JTAG specification support.	O	OD	SE	P Processor Line H Processor Line U Processor Line

Signal Name	Description	Dir.	Buffer Type	Link Type	Availability
PROC_JTAG_TMS	Test Mode Select: A JTAG specification support signal used by debug tools.	I	GTL	SE	P Processor Line H Processor Line U Processor Line
PROC_JTAG_TRST#	Test Reset: Resets the Test Access Port (TAP) logic. This signal should be driven low during power on Reset.	I	GTL	SE	S Processor Line P Processor Line H Processor Line U Processor Line
DBG_PMODE					P Processor Line H Processor Line U Processor Line

Error and Thermal Protection Signals

Error and Thermal Protection Signals

Signal Name	Description	Dir.	Buffer Type	Link Type	Availability
-------------	-------------	------	-------------	-----------	--------------

Signal Name	Description	Dir.	Buffer Type	Link Type	Availability
CATERR#	Catastrophic Error: This signal indicates that the system has experienced a catastrophic error and cannot continue to operate. The processor will set this signal for non-recoverable machine check errors or other unrecoverable internal errors. CATERR# is used for signaling the following types of errors: Legacy MCERRs, CATERR# is asserted for 16 BCLKs. Legacy IERRs, CATERR# remains asserted until warm or cold reset.	O	OD	SE	S Processor Line P Processor Line H Processor Line U Processor Line
PECI	Platform Environment Control Interface: A serial sideband interface to the processor. It is used primarily for thermal, power, and error management. Details regarding the PEFI electrical specifications, protocols and functions can be found in the RS-Platform Environment Control Interface (PECI) Specification, Revision 3.0.	I/O	PECI, Async	SE	S Processor Line P Processor Line H Processor Line U Processor Line
PROCHOT#	Processor Hot: PROCHOT# goes active when the processor temperature monitoring sensor(s) detects that the processor has reached its maximum safe operating temperature. This indicates that the processor Thermal Control Circuit (TCC) has been activated, if enabled. This signal can also be driven to the processor to activate the TCC.	I/O	I:GTL / O:OD	SE	S Processor Line P Processor Line H Processor Line U Processor Line

Signal Name	Description	Dir.	Buffer Type	Link Type	Availability
THERMTRIP#	Thermal Trip: The processor protects itself from catastrophic overheating by use of an internal thermal sensor. This sensor is set well above the normal operating temperature to ensure that there are no false trips. The processor will stop all executions when the junction temperature exceeds approximately 130 °C. This is signaled to the system by the THRMTRIP# pin.	O	OD	SE	S Processor Line P Processor Line H Processor Line U Processor Line

Power Sequencing Signals

Power Sequencing Signals

Signal Name	Description	Dir.	Buffer Type	Link Type	Availability
PROCPWRGD	Processor Power Good: The processor requires this input signal to be a clean indication that the VCC1P05V_PROC and VDD2 power supplies are stable and within specifications. This requirement applies regardless of the S-state of the processor. 'Clean' implies that the signal will remain low (capable of sinking leakage current), without glitches, from the time that the power supplies are turned on until they come within specification. The signal should then transition monotonically to a high state.	I	CMOS	SE	All Processor Lines

Signal Name	Description	Dir.	Buffer Type	Link Type	Availability
VCCST_PWRGD	VCCST Power Good: The processor requires this input signal to be a clean indication that the VCC1P05_PROC and VDD2 power supplies are stable and within specifications. This signal should have a valid level during both S0 and S3 power states. 'Clean' implies that the signal will remain low (capable of sinking leakage current), without glitches, from the time that the power supplies are turned on until they come within specification. The signal then transition monotonically to a high state.	I	CMOS	SE	All Processor Lines
VCCST_PWRGD_SX	VCCST_PWRGD_SX: the processor required this input signal to be a clean indicator that there is a Sx state, the net will be dropped in Sx, the signal will support IO during.	I	CMOS	SE	All Processor Lines
SKTOCC#	Socket Occupied: Pulled down directly (0 Ohms) on the processor package to the ground. There is no connection to the processor silicon for this signal. System board designers may use this signal to determine if the processor is present.	N/A	N/A	SE	S/U9 Processor Line
VIDSOUT	VIDSOUT, VIDSCK, VIDALERT#: These signals comprise a three-signal serial synchronous interface used to transfer power management information between the processor and the voltage regulator controllers.	I/O	I:GTL/ O:OD	SE	All Processor Lines
VIDSCK		O	OD		
VIDALERT#		I	CMOS		

Signal Name	Description	Dir.	Buffer Type	Link Type	Availability
PM_SYNC	Power Management Sync: A sideband signal to communicate power management status from the PCH to the processor. PCH report EXTTS#/EVENT# status to the processor.	I	CMOS	SE	S-Processor Line
PM_DOWN	Power Management Down: Sideband to PCH. Indicates processor wake up event EXTTS# on PCH. The processor combines the pin status into the OLTM/CLTM.	O	CMOS	SE	S-Processor Line

Note: Refer to the AC,DC specification data for more details on the Buffer type power spec requirement. For the buffer type for CMOS, refer [CMOS DC Specifications](#). For the buffer type for electric DC specification data, refer to GTL table in [GTL and OD DC Specification](#).

Processor Power Rails

Processor Power Rails Signals

Signal Name	Description	Dir.	Buffer Type	Link Type	Availability
VCCCORE	Processor IA Cores and Ring power rail	I	PWR	—	All Processor Line
VCCGT	Processor Graphics power rail	I	PWR	—	All Processor Line
VCCSA	Processor System Agent power rail	I	PWR		U9 Processor Line
VCCANA	Support internal Analog rails, TCSS, Display, PCIE and other internal Blocks	I	PWR		U9 Processor Line

Signal Name	Description	Dir.	Buffer Type	Link Type	Availability
VCCIN_AUX	Support internal FIVR's, SA, PCIe, Display IO and other internal Blocks.	I	PWR	—	All Processor Line
VCCIN_AUX_FLTR	Support internal FIVR's, SA, PCIe, Display IO and other internal Blocks. this pin should be connected to decoupling for filter.	I	PWR	—	All Processor Line
VCC1P05_PROC	Sustain and Sustain Gated Power Rail	I	PWR	—	All Processor Line
VCC1P8_PROC	PCIe PHY Power 1.8V Rail	I	PWR	—	S Processor Line H Processor Line P Processor Line U15 Processor Line
VDD2	System Memory power rail	I	PWR	—	All Processor Line
VDD2_EDGECAP	Internal power pin, this pin should be connected to a decoupling capacitor and ground	I	PWR	—	S Processor Line
VCCIN_AUX_EDGECAP	Internal power pin, this pin should be connected to a decoupling capacitor and ground	I	PWR	—	S Processor Line

Signal Name	Description	Dir.	Buffer Type	Link Type	Availability
VDD2_DDR5_SENSE	Isolated, low impedance DDR5 voltage sense pins.	N/A	PWR_SENSE	—	S Processor Line
VCCGT_SENSE	Isolated, low impedance voltage sense pins. They can be used to sense or measure voltage near the silicon.	N/A	PWR_SENSE	—	All Processor Line
VCC_SENSE					All Processor Line
VCCIN_AUX_SENSE / VCCINAUX_SENSE					All Processor Line
VCC1P05_PROC_SENSE					S Processor Line
VCCSA_SENSE	Isolated, low impedance voltage sense pins. They can be used to sense or measure voltage near the silicon.	N/A	PWR_SENSE	—	U9 Processor Line
VCCANA_SENSE					
VCC1P05_PROC_OUT	VCC1P05_PROC_OUT is the power provider to the balls AR14 and AT12, so those three balls should be connected at board level.	O	PWR	—	H Processor Line P Processor Line U Processor Line



Signal Name	Description	Dir.	Buffer Type	Link Type	Availability
VCC_DISPIO	DDI PHY power rail (Shorted on package): Note: When no MIPI DSI interface is been used (only eDP), VCC_DISPIO should be shorted with VCC1P05_PROC_OUT , VCC_MIPILP can be left N.C.	I	PWR	—	H Processor Line P Processor Line U Processor Line
VCC_MIPILP	 Note: When MIPI DSI interface is been used, VCC_MIPILP should be connected to 1.24v (on board VR), VCC_DISPIO can be left N.C.	I	PWR	—	H Processor Line P Processor Line U Processor Line

Processor Ground Rails Signals

Signal Name	Description	Dir.	Buffer Type	Link Type	Availability
VSSGT_SENSE	Isolated, low impedance Ground sense pins. They can be used for the reference ground near the silicon.	N/A	GND_SENSE	—	All Processor Line
VSS_SENSE					
VSSIN_AUX_SENSE / VSSINAUX_SENSE					
VSSSA_SENSE	Isolated, low impedance Ground sense pins. They can be used for the reference ground near the silicon.	N/A	GND_SENSE	—	U9 Processor Line

Signal Name	Description	Dir.	Buffer Type	Link Type	Availability
VSSANA_SENSE					

Ground and Reserved Signals

The following are the general types of reserved (RSVD) signals and connection guidelines:

- RSVD – these signals should not be connected
- RSVD_TP – these signals should be routed to a test point
- _NCTF – these signals are non-critical to function and should not be connected.

Arbitrary connection of these signals to VCC, VDD2, VSS, or to any other signal (including each other) may result in component malfunction or incompatibility with future processors. Refer to the table below.

For reliable operation, always connect unused inputs or bi-directional signals to an appropriate signal level. Unused active high inputs should be connected through a resistor to ground (VSS). Unused outputs may be left unconnected however, this may interfere with some Test Access Port (TAP) functions, complicate debug probing and prevent boundary scan testing. A resistor should be used when tying bi-directional signals to power or ground. When tying any signal to power or ground the resistor can also be used for system testability. Resistor values should be within $\pm 20\%$ of the impedance of the baseboard trace, unless otherwise noted in the appropriate platform design guidelines.

GND, RSVD, and NCTF Signals

Signal Name	Description
VSS	Ground: Processor ground node
VSS_NCTF	Non-Critical To Function: These signals are for package mechanical reliability and should not be connected on the board.
RSVD	Reserved: All signals that are RSVD should not be connected on the board.
RSVD_NCTF	Reserved Non-Critical To Function: RSVD_NCTF should not be connected on the board.

Signal Name	Description
RSVD_TP	Test Point: Intel recommends to route each RSVD_TP to an accessible test point. Intel may require these test points for platform specific debug. Leaving these test points inaccessible could delay debug by Intel.

Processor Internal Pull-Up / Pull-Down Terminations

Signal Name	Pull Up/Pull Down	Rail	Value (K Ω)
BPM#[3:0]	Pull Up/Pull Down	VCC_CFG_PU_OUT	1
PROC_PREQ#	Pull Up	VCC1p05_PROC	1
PROC_TDI	Pull Up	VCC1p05_PROC	1
PROC_TMS	Pull Up	VCC1p05_PROC	1
PROC_TRST#	Pull Down	VCC1p05_PROC	1
PROC_TCK	Pull Down	VCC1p05_PROC	1
CFG[17:0]	Pull Up	VCC_CFG_PU_OUT	1

Electrical Specifications

Processor Power Rails

Power Rail	Description	HX SBGA Processor Line Controls	P/H/U 15W Processor Line Controls	U 9W Processor Line Controls
V _{CC} CORE	Processor IA Cores Power Rail	SVID	SVID	SVID
V _{CC} GT	Graphic Power Rail	SVID	SVID	SVID
V _{CC} IN_AUX ³	Support internal FIVR's 1, SA, PCIe, Display IO and other internal Blocks.	PCH VID	PCH VID	PCH VID
V _{CC} SA ¹	Processor System Agent Power Rail	-----	-----	SVID
V _{CC} 1P05_ PROC ⁴	Sustain and Sustain Gated Power Rail	Fixed	Fixed	Fixed
V _{CC} 1p8_PROC	PCIe PHY Power 1.8V Rail	Fixed	Fixed	-----
V _{CC} ANA	Support internal Analog rails, TCSS, Display, PCIe and other internal Blocks	-----	-----	Fixed
V _{CC} MIPILP	DDI PHY power rail for MIPI DSI interface	-----	Fixed	Fixed
V _{DD} 2	Integrated Memory Controller Power Rail	Fixed (Memory technology dependent)	Fixed (Memory technology dependent)	Fixed (Memory technology dependent)

Power Rail	Description	HX SBGA Processor Line Controls	P/H/U 15W Processor Line Controls	U 9W Processor Line Controls
<p>Notes:</p> <ol style="list-style-type: none"> 1. FIVR = Fully Integrated Voltage Regulator. For details, refer to Voltage Regulator. 2. V_{CCIN_AUX} has a few discrete voltages defined by PCH VID. V_{CC1P05_PROC}, for HX SBGA processor the power rail is connected to a platform voltage regulator to supply power to the sustaining power rails , P/H/ U 15W-Processor line power rail is connected to $V_{CC1P05_OUT_FET}$ rail through a power gate at platform, to supply power to the sustain gated power rails. 3. $V_{CCMIPILP}$: When MIPI DSI interface is been used, this power rail should be connected to 1.24 V rail. 				

Power and Ground Pins

All power pins should be connected to their respective processor power planes, while all VSS pins should be connected to the system ground plane. Use of multiple power and ground planes is recommended to reduce $I \cdot R$ drop.

Voltage Regulator

The processor has few internal voltage regulation to support internal power rails, for example V_{CCSA} in Mobile and DT segments.

The V_{CCCORE} and rail V_{CCGT} will remain a VID-based voltage with a loadline similar to the core voltage rail in previous processors.

VCC Voltage Identification (VID)

Intel processors/chipsets are individually calibrated in the factory to operate on a specific voltage/frequency and operating-condition curve specified for that individual processor. In normal operation, the processor autonomously issues voltage control requests according to this calibrated curve using the serial voltage-identifier (SVID) interface. Altering the voltage applied at the processor/chipset causing operation outside of this calibrated curve is considered out-of-specification operation.

The SVID bus consists of three open-drain signals: clock, data, and alert# to both set voltage-levels and gather telemetry data from the voltage regulators. Voltages are controlled per an 8-bit integer value, called a VID, that maps to an analog voltage level. An offset field also exists that allows altering the VID table. Alert can be used to inform the processor that a voltage-change request has been completed or to interrupt the processor with a fault notification.

DC Specifications

The processor DC specifications in this section are defined at the processor signal pins, unless noted otherwise.

- The DC specifications for the DDR4/DDR5 signals are listed in the *Voltage and Current Specifications* section.
- The DC specifications for the LPDDR4x/DDR4 signals are listed in the *Voltage and Current Specifications* section.
- The *Voltage and Current Specifications* section lists the DC specifications for the processor and are valid only while meeting specifications for junction temperature, clock frequency, and input voltages. Read all notes associated with each parameter.
- AC tolerances for all rails include voltage transients and voltage regulator voltage ripple up to 1 MHz. Refer additional guidance for each rail.

Processor Power Rails DC Specifications

VCC_{CORE} DC Specifications

Processor VCC_{CORE} Active and Idle Mode DC Voltage and Current Specifications

Symbol	Parameter	Segment	Minimum	Typical	Maximum	Unit	Note ¹
Operating Voltage	Voltage Range for Processor Operating Mode	P/U-Processor Line	0	—	1.6	V	1,2,3,7,12,15
Operating Voltage	Voltage Range for Processor Operating Mode	HX Processor Line, SBGA 8+ 8 Core (55W)	0	—	1.72	V	1,2,3,7,12,15

Symbol	Parameter	Segment	Minimum	Typical	Maximum	Unit	Note ¹
Operating Voltage	Voltage Range for Processor Operating Mode	HX Processor Line, SBGA 4+ 8 Core (55W)	0	—	1.72	V	1,2,3,7,12,15
Operating Voltage	Voltage Range for Processor Operating Mode	S-Processor Line	0	—	1.72	V	1,2,3,7,12,15
IccMAX (H Processor)	Maximum Processor ICC	H-Processor Line (45W) 6+8/ 6+4 - Core	—	—	160	A	4,5,6,7,11
IccMAX (H Processor)	Maximum Processor ICC	H-Processor Line (45W) 4+8/4+4 - Core	—	—	120	A	4,5,6,7,11
IccMAX (P Processor)	Maximum Processor ICC	P-Processor Line (28W) 6+8 -Core	—	—	109	A	4,5,6,7,11
IccMAX (P Processor)	Maximum Processor ICC	P-Processor Line (28W) 4+8 -Core	—	—	85	A	4,5,6,7,11

Symbol	Parameter	Segment	Minimum	Typical	Maximum	Unit	Note ¹
IccMAX (U15 Processor)	Maximum Processor ICC	U-Processor Line (15W)	—	—	80	A	4,5,6,7,11
IccMAX (U9 Processor)	Maximum Processor ICC	U-Processor Line (9W)	—	—	50	A	4,5,6,7,11
IccMAX (S Processor)	Maximum Processor ICC	S-Processor Line (125W) 8+4 -Core	—	—	240	A	4,5,6,7,11
IccMAX (S Processor)	Maximum Processor ICC	S-Processor Line (125W) 6+4 -Core	—	—	175	A	4,5,6,7,11
IccMAX (S Processor)	Maximum Processor ICC	S-Processor Line (125W) 8+8 -Core	—	—	280	A	4,5,6,7,11
IccMAX (S Processor)	Maximum Processor ICC	S-Processor Line (150W) 8+8 -Core	—	—	280	A	4,5,6,7,11

Symbol	Parameter	Segment	Minimum	Typical	Maximum	Unit	Note ¹
IccMAX (S Processor)	Maximum Processor ICC	S-Processor Line (65W) 8+8 -Core	—	—	240	A	4,5,6,7,11
IccMAX (S Processor)	Maximum Processor ICC	S-Processor Line (65W) 8+4-Core	—	—	220	A	4,5,6,7,11
IccMAX (S Processor)	Maximum Processor ICC	S-Processor Line (35W) 8+8 -Core	—	—	154	A	4,5,6,7,11
IccMAX (S Processor)	Maximum Processor ICC	S-Processor Line (35W) 8+4 -Core	—	—	145	A	4,5,6,7,11
IccMAX (S BGA H55 Processor)	Maximum Processor ICC	HX Processor Line, SBGA 8+ 8 Core (55W)	—	—	200	A	4,5,6,7,11
IccMAX (S BGA H55 Processor)	Maximum Processor ICC	HX Processor Line, SBGA 4+ 8 Core (55W)	—	—	160	A	4,5,6,7,11

Symbol	Parameter	Segment	Minimum	Typical	Maximum	Unit	Note ¹
IccMAX (S Processor)	Maximum Processor ICC	S-Processor Line (65W) 6+0 -Core	—	—	151	A	4,5,6,7,11
IccMAX (S Processor)	Maximum Processor ICC	S-Processor Line (60W/58W) 4+0 -Core	—	—	110	A	4,5,6,7,11
IccMAX (S Processor)	Maximum Processor ICC	S-Processor Line (35W) 6+0 -Core	—	—	100	A	4,5,6,7,11
IccMAX (S Processor)	Maximum Processor ICC	S-Processor Line (35W) 4+0 -Core	—	—	90	A	4,5,6,7,11
IccMAX (S Processor)	Maximum Processor ICC	S-Processor Line (35W) 2+0 -Core	—	—	37	A	4,5,6,7,11
IccMAX (S Processor)	Maximum Processor ICC	S-Processor Line (46W) 2+0 -Core	—	—	49	A	4,5,6,7,11

Symbol	Parameter	Segment	Minimum	Typical	Maximum	Unit	Note ¹
I _{CC} TDC	Thermal Design Current (TDC) for processor V _{CC} CORE Rail	—	—	—	VR_TDC	A	9
TOB _{VCC}	DC Tolerance	PS0, PS1, PS2, PS3	—	—	±20	mV	3, 6, 8
TOB _{VCC} +Ripple	Total Tolerance	PS0, PS1, PS2, PS3	—	—	-35 /+50	mV	3, 6, 8, 16
DC_LL	Loadline slope within the VR regulation loop capability	H-Processor Line 4+8/4+4 (45W)	0	—	2.3	mΩ	10, 13, 14
DC_LL	Loadline slope within the VR regulation loop capability	H-Processor Line 6+8/6+4 (45W)	0	—	2.3	mΩ	10, 13, 14
DC_LL	Loadline slope within the VR regulation loop capability	P-Processor Line 6+8 (28W)	0	—	2.3	mΩ	10, 13, 14

Symbol	Parameter	Segment	Minimum	Typical	Maximum	Unit	Note ¹
DC_LL	Loadline slope within the VR regulation loop capability	P-Processor Line 4+8 (28W)	0	—	2.3	mΩ	10,13,14
DC_LL	Loadline slope within the VR regulation loop capability	U-Processor Line (15W)	0	—	2.8	mΩ	10,13,14
DC_LL	Loadline slope within the VR regulation loop capability	U-Processor Line (9W)	0	—	4.5	mΩ	10,13,14
DC_LL	Loadline slope within the VR regulation loop capability	HX Processor Line, SBGA 8+ 8 Core (55W)	0	—	1.7	mΩ	10,13,14
DC_LL	Loadline slope within the VR regulation loop capability	HX Processor Line, SBGA 4+ 8 Core (55W)	0	—	1.7	mΩ	10,13,14

Symbol	Parameter	Segment	Minimum	Typical	Maximum	Unit	Note ¹
DC_LL	Loadline slope within the VR regulation loop capability	S-Processor Line 8+8/8+4 Core (125W)	0	—	1.1	mΩ	10,13,14
		S-Processor Line 6+4 Core (125W)	0	—	1.7	mΩ	10,13,14
DC_LL	Loadline slope within the VR regulation loop capability	S-Processor Line 8+8 Core (65W)	0	—	1.1	mΩ	10,13,14
		S-Processor Line 8+8 Core (35W)	0	—	1.7	mΩ	10,13,14
		S-Processor Line 6+0 Core (65W/35W)	0	—	1.7	mΩ	10,13,14
		S-Processor Line 4+0 Core	0	—	1.7	mΩ	10,13,14

Symbol	Parameter	Segment	Minimum	Typical	Maximum	Unit	Note ¹
		S-Processor Line 2+0 Core	0	—	1.7	mΩ	10,13,14
		S-Processor Line 8+4 Core (65W)	0	—	1.1	mΩ	10,13,14
		S-Processor Line 8+4 Core (35W)	0	—	1.7	mΩ	10,13,14
AC_LL	AC Loadline 3	P-Processor Line 6+8 (28W) P-Processor Line 4+8 (28W)	—	—	<ul style="list-style-type: none"> Below 400kHz: z:2.3 400kHz - 2MHz: linear decrease with log (frequency) from 2.3 to 1.9 Above 2MHz: 1.9 	mΩ	10,13,14



Symbol	Parameter	Segment	Minimum	Typical	Maximum	Unit	Note ¹
		U-Processor Line (15W)			<ul style="list-style-type: none"> • Below 400kHz: 2.8 • 400kHz - 2MHz: linear decrease with log (frequency) from 2.8 to 2.2 • Above 2MHz: 2.2 		
	AC Loadline 3	U - Processor Line (9W)	—	—	Same as DC LL	mΩ	10,13,14
AC_LL	AC Loadline 3	H-Processor Line (45W)	—	—	<ul style="list-style-type: none"> • Below 400kHz: 2.3 • 400kHz - 2MHz: linear decrease with log (frequency) from 2.3 to 1.9 • Above 2MHz: 1.9 	mΩ	10,13,14

Symbol	Parameter	Segment	Minimum	Typical	Maximum	Unit	Note ¹
AC_LL	AC Loadline 3	HX - Processor Line SBGA (55W)	0	—	Same as DC LL	mΩ	10,13,14
AC_LL	AC Loadline 3	S Processor Line	0	—	Same as DC LL	mΩ	10,13,14
T_OVS_TDP_MAX	Maximum Overshoot time TDP/virus mode	—	—	—	500	μs	
V_OVS_TDP_MAX/virus_MAX	Maximum Overshoot at TDP/virus mode	—	—	—	10	%	

Symbol	Parameter	Segment	Minimum	Typical	Maximum	Unit	Note ¹
<p>Notes:</p> <ol style="list-style-type: none"> All specifications in this table are based on estimates and simulations or empirical data. These specifications will be updated with characterized data from silicon measurements at a later date. Each processor is programmed with a maximum valid voltage identification value (VID) that is set at manufacturing and cannot be altered. Individual maximum VID values are calibrated during manufacturing such that two processors at the same frequency may have different settings within the VID range. Note that this differs from the VID employed by the processor during a power management event (Adaptive Thermal Monitor, Enhanced Intel Speed-step Technology, or low-power states). The voltage specification requirements are measured across Vcc_SENSE and Vss_SENSE as near as possible to the processor. The measurement needs to be performed with a 20MHz bandwidth limit on the oscilloscope, 1.5pF maximum probe capacitance, and 1Ω minimum impedance. The maximum length of the ground wire on the probe should be less than 5mm. Ensure external noise from the system is not coupled into the oscilloscope probe. Processor VccCORE VR to be designed to electrically support this current. Processor VccCORE VR to be designed to thermally support this current indefinitely. Long term reliability cannot be assured if tolerance, ripple, and core noise parameters are violated. Long term reliability cannot be assured in conditions above or below Maximum/Minimum functional limits. PSx refers to the voltage regulator power state as set by the SVID protocol. Refer to Intel Platform Design Studio (iPDS) for the minimum, typical, and maximum VCC allowed for a given current and Thermal Design Current (TDC). LL measured at sense points. Typ column represents IccMAX for commercial application it is NOT a specification - it's a characterization of limited samples using limited set of benchmarks that can be exceeded. Operating voltage range in steady state. LL spec values should not be exceeded. If exceeded, power, performance and reliability penalty are expected. Load Line (DC) should be measured by the VRTT tool and programmed accordingly via the BIOS Load Line override setup options. DC Load Line BIOS programming directly affects power measurements (DC). An IMVP9.1 controller to support VccCORE need to have an offset voltage capability and potentially VccCORE output voltage (VID+Offset) may be higher than 1.5V. 							

Symbol	Parameter	Segment	Minimum	Typical	Maximum	Unit	Note ¹
16. Ripple can be higher if DC TOB is below 20mV, as long as Total TOB is within -35mV/+50mV.							

VccIN_AUX Supply DC Voltage and Current Specifications

Symbol	Parameter	Segment	Minimum	Typical	Maximum	Unit	Note ¹
VCCIN_AUX	Voltage Range	P-Processor Line	—	1.8	—	V	1,2,3,7
VCCIN_AUX	Voltage Range	H-Processor Line	—	1.8	—	V	1,2,3,7
VCCIN_AUX	Voltage Range	U 15W-Processor Line	—	1.8	—	V	1,2,3,7
VCCIN_AUX	Voltage Range	U 9W-Processor Line	—	1.65	1.8	V	1,2,3,7,8
VCCIN_AUX	Voltage Range	HX - Processor Line SBGA (55W)	—	1.8	—	V	1,2,3,7
VCCIN_AUX	Voltage Range	S - Processor Line	—	1.8	—	V	1,2,3,7
ICCMAX	Maximum VccIN_AUX Icc	H-Processor Line (45W)	0	—	34.2	A	1,2

Symbol	Parameter	Segment	Minimum	Typical	Maximum	Unit	Note ¹
I _{CCMAX}	Maximum V _{CCIN_AUX} I _{CC}	P-Processor Line (28W) 6+8-Core	0	—	32	A	1,2
I _{CCMAX}	Maximum V _{CCIN_AUX} I _{CC}	P-Processor Line (28W) 4+8-Core	0	—	32	A	1,2
I _{CCMAX}	Maximum V _{CCIN_AUX} I _{CC}	U-Processor Line (15W)	0	—	32	A	1,2
I _{CCMAX}	Maximum V _{CCIN_AUX} I _{CC}	U-Processor Line (9W)	0	—	12	A	1,2,7
I _{CCMAX}	Maximum V _{CCIN_AUX} I _{CC}	S-Processor Line (125W) 8+ 8/ 8+4/ 6+4-Core	0	—	33	A	1,2
I _{CCMAX}	Maximum V _{CCIN_AUX} I _{CC}	S-Processor Line (65W/35W) 8+4-Core	0	—	33	A	1,2
I _{CCMAX}	Maximum V _{CCIN_AUX} I _{CC}	S-Processor Line (65W) 8+ 8-Core	0	—	33	A	1,2

Symbol	Parameter	Segment	Minimum	Typical	Maximum	Unit	Note ¹
		S-Processor Line (35W) 8+8-Core	0	—	33	A	1,2
		S-Processor Line (65W) 6+0-Core	0	—	33	A	1,2
		S-Processor Line (35W) 6+0-Core	0	—	33	A	1,2
		S-Processor Line 2+0/ 4+0 - Core	0	—	33	A	1,2
ICC _{MAX}	Maximum VccIN_ AUC Icc	HX - Processor Line SBGA (55W)	0	—	33	A	1,2
TOB _{VCC}	Voltage Tolerance Budget	P-Processor Line	—	—	AC+DC: +5/-10	%	1,3, 6
TOB _{VCC}	Voltage Tolerance Budget	H-Processor Line	—	—	AC+DC: +5/-10	%	1,3, 6
TOB _{VCC}	Voltage Tolerance Budget	U 15W-Processor Line	—	—	AC+DC: +5/-10	%	1,3, 6

Symbol	Parameter	Segment	Minimum	Typical	Maximum	Unit	Note ¹
TOB _{VCC}	Voltage Tolerance Budget	U 9W-Processor Line	—	—	AC+DC: +5/-10 (match for 1.8V)	%	1,3,6
			—	—	AC+DC: +/-7.5 (match for 1.65V)	%	1,3,6
TOB _{VCC}	Voltage Tolerance Budget	S - Processor Line	—	—	AC+DC:+5/-10	%	1,3,6
TOB _{VCC}	Voltage Tolerance Budget	HX-Processor Line	—	—	AC+DC:+5/-10	%	1,3,6
AC_LL	AC Loadline	H-Processor Line (45W)	—	—	3.4	mΩ	4,5
DC_LL	DC Loadline				2.0		
AC_LL	AC Loadline	P-Processor Line (28W) 6+8-Core	—	—	3.4	mΩ	4,5
DC_LL	DC Loadline				2.0		
AC_LL	AC Loadline	P-Processor Line (28W) 4+8-Core	—	—	3.4	mΩ	4,5
DC_LL	DC Loadline				2.0		
AC_LL	AC Loadline	U-Processor Line (15W)	—	—	3.4	mΩ	4,5

Symbol	Parameter	Segment	Minimum	Typical	Maximum	Unit	Note ¹
DC_LL	DC Loadline				2.0		
AC_LL	AC Loadline	U-Processor Line (9W)	—	—	5.3	mΩ	4,5,7
DC_LL	DC Loadline				—		
DC_LL	DC Loadline	HX - Processor Line SBGA (55W)	—	—	2.0	mΩ	4,5
DC_LL	DC Loadline	S-Processor Line	—	—	2.0	mΩ	4,5
AC_LL	AC Loadline	S Processor Line	—	—	<ul style="list-style-type: none"> • 100 KHz-4.5 MHz: 3.9 • 4.5 MHz-6.3 MHz: increasing linearly with log (frequency) from 3.9 to 4.5 • 6.3MHz- 22.5MHz: 4.5 	mΩ	4,5
AC_LL	AC Loadline	HX - Processor Line SBGA (55W)	—	—	<ul style="list-style-type: none"> • 100 KHz-13 MHz: 3.3mΩ • 13MHz-20MHz: linear increasing with log(frequency) from 3.3mΩ to 5mΩ 	mΩ	4,5

Symbol	Parameter	Segment	Minimum	Typical	Maximum	Unit	Note ¹
<p>Notes:</p> <ol style="list-style-type: none"> All specifications in this table are based on estimates and simulations or empirical data. These specifications will be updated with characterized data from silicon measurements at a later date. Long term reliability cannot be assured in conditions above or below Maximum/Minimum functional limits. The voltage specification requirements are measured on package pins as near as possible to the processor with an oscilloscope set to 100 MHz bandwidth, 1.5 pF maximum probe capacitance, and 1 MΩ minimum impedance. The maximum length of ground wire on the probe should be less than 5 mm. Ensure external noise from the system is not coupled into the oscilloscope probe. LL measured at sense points. LL specification values should not be exceeded. If exceeded, power, performance, and reliability penalty are expected. The LL values are for reference. Must still need to meet the voltage tolerance specification. Voltage Tolerance budget values Include ripples V_{CCIN_AUX} is having few point of voltage define by CPU VID 							

VccGT DC Specifications

Processor Graphics (VccGT) Supply DC Voltage and Current Specifications

Symbol	Parameter	Segment	Minimum	Typical	Maximum	Unit	Note ¹
Operating voltage	Active voltage Range for V _{CCGT}	All Processor Line	0	—	1.5	V	2, 3, 6, 8, 11
I _{CCMAX_GT} (S-Processors)	Max. Current for Processor or Graphics Rail	S-Processor Line 8+8/ 8+4/ 6+4 Core	—	—	30	A	6

Symbol	Parameter	Segment	Minimum	Typical	Maximum	Unit	Note ¹
ICC _{MAX_GT} (S-Processors)	Max. Current for Processor or Graphics Rail	S-Processor Line 6+0/4+0/2+0 Core	—	—	30	A	6
ICC _{MAX_GT} (S-BGA H55 Processors)	Max. Current for Processor or Graphics Rail	HX Processor Line, SBGA (55W)	—	—	30	A	6
ICC _{MAX_GT} (H-Processors)	Max. Current for Processor or Graphics Rail	H-Processor Line 6+8 /6+4 Core (45W)	—	—	55	A	6
ICC _{MAX_GT} (H-Processors)	Max. Current for Processor or Graphics Rail	H-Processor Line 4+8/4+4 Core (45W)	—	—	55	A	6
ICC _{MAX_GT} (P-Processors)	Max. Current for Processor or Graphics Rail	P-Processor Line 6+8 Core (28W)	—	—	55	A	6

Symbol	Parameter	Segment	Minimum	Typical	Maximum	Unit	Note ¹
ICC _{MAX_GT} (P-Processors)	Max. Current for Processor or Graphics Rail	P-Processor Line 4+8/ 2+8 Core (28W)	—	—	55	A	6
ICC _{MAX_GT} (U15-Processors)	Max. Current for Processor or Graphics Rail	U-Processor Line (15W)	—	—	40	A	6
ICC _{MAX_GT} (U9-Processors)	Max. Current for Processor or Graphics Rail	U-Processor Line (9W)	—	—	25	A	6,12
ICC _{TDC_GT}	Thermal Design Current (TDC) for Processor or Graphics Rail	—	—	—	—	A	6
TOB _{VCCGT}	DC Tolerance	PS0, PS1, PS2, PS3	—	—	±20	mV	3,4
TOB _{VCCGT} +Ripple	Total Tolerance	PS0, PS1, PS2, PS3	—	—	-35 /+50	mV	3, 4,13

Symbol	Parameter	Segment	Minimum	Typical	Maximum	Unit	Note ¹
DC_LL (Process ors)	DC Loadline	HX Processor Line, SBGA (55W)	—	—	4.0	mΩ	7, 9, 10
DC_LL (Process ors)	DC Loadline	S Processor Line	—	—	4.0	mΩ	7, 9, 10
AC_LL (S Process ors)	AC Loadline	HX Processor Line	—	—	<ul style="list-style-type: none"> • Below 300KHz: 4.0 • 300KHz-1MHz: linear decrease with log(frequency) from 4.0 to 3.0 • Above 1MHz: 3.0 	mΩ	7, 9, 10
AC_LL (S Process ors)	AC Loadline	S -Processor Line	—	—	AC LL the same DC LL	mΩ	7, 9, 10
DC_LL (P/H Process ors)	DC Loadline	P-Processor Line	—	—	3.2	mΩ	7, 9, 10
DC_LL (P/H Process ors)	DC Loadline	H-Processor Line	—	—	3.2	mΩ	7, 9, 10
DC_LL (U15 Process ors)	DC Loadline	U-Processor Line (15W)	—	—	3.2	mΩ	7, 9, 10

Symbol	Parameter	Segment	Minimum	Typical	Maximum	Unit	Note ¹
DC_LL (U9 Processors)	DC Loadline	U-Processor Line (9W)	—	—	5.5	mΩ	7, 9, 10, 1 2
AC_LL (H Processors)	AC Loadline	H -Processor Line	—	—	<ul style="list-style-type: none"> Below 400kHz: 3.2 400kHz-2MHz: linear decrease with log (frequency) from 3.2 to 2.4 Above 2MHz: 2.4 	mΩ	7, 9, 10, 1 2
AC_LL (P Processors)	AC Loadline	P-Processor Line	—	—	<ul style="list-style-type: none"> Below 400kHz: 3.2 400kHz-2MHz: linear decrease with log (frequency) from 3.2 to 2.4 Above 2MHz: 2.4 	mΩ	7, 9, 10, 1 2
AC_LL (U Processors)	AC Loadline	U -Processor Line	—	—	AC LL same as DC LL	mΩ	7, 9, 10
T_ OVS_ MAX	Max Overshoot time	—	—	—	10	μs	
V_ OVS_ MAX	Max Overshoot	—	—	—	70	mV	

Symbol	Parameter	Segment	Minimum	Typical	Maximum	Unit	Note ¹
<p>Notes:</p> <ol style="list-style-type: none"> All specifications in this table are based on estimates and simulations or empirical data. These specifications will be updated with characterized data from silicon measurements at a later date. Each processor is programmed with a maximum valid voltage identification value (VID), which is set at manufacturing and cannot be altered. Individual maximum VID values are calibrated during manufacturing such that two processors at the same frequency may have different settings within the VID range. This differs from the VID employed by the processor during a power or thermal management event (Intel Adaptive Thermal Monitor, Enhanced Intel® SpeedStep Technology, or low-power states). PSx refers to the voltage regulator power state as set by the SVID protocol. Each processor is programmed with a maximum valid voltage identification value (VID), which is set at manufacturing and cannot be altered. Individual maximum VID values are calibrated during manufacturing such that two processors at the same frequency may have different settings within the VID range. This differs from the VID employed by the processor during a power or thermal management event (Intel Adaptive Thermal Monitor, Enhanced Intel® SpeedStep Technology, or low-power states). Operating voltage range in steady state. Load Line measured at the sense point. An IMVP9.1 controller to support VCCGT need to have an offset voltage capability and potentially VCCGT output voltage (VID+Offset) may be higher than 1.5V. U9 Processors will have few options of VR, the data is for IMVP VR. Ripple can be higher if DC TOB is below 20mV, as long as Total TOB is within -35mV/+50mV. 							

VccSA DC Specifications

Processor Graphics (VccSA) Supply DC Voltage and Current Specifications

Symbol	Parameter	Segment	Minimum	Typical	Maximum	Unit	Note ¹
Operating voltage	Active voltage Range for VccSA	All Processor Line	0	—	1.5	V	2, 3, 6, 8, 11

Symbol	Parameter	Segment	Minimum	Typical	Maximum	Unit	Note ¹
I _{CCMAX_SA} (U9-Processors)	Max. Current for Processor or System Agent Rail	U-Processor Line Core (9W)	—	—	12.9	A	6,12
I _{CC TDC_SA}	Thermal Design Current (TDC) for Processor or System Agent Rail	—	—	—		A	6
T _{OBVCCSA}	DC Tolerance	PS0, PS1, PS2, PS3	—	—	±20	mV	3,4
T _{OBVCCSA} +Ripple	Total Tolerance	PS0, PS1, PS2, PS3	—	—	-35 /+50	mV	3, 4,12
DC_LL (U9 Processors)	DC Loadline	U-Processor Line Core (9W)	—	—	8.0	mΩ	7, 9, 10,12
AC_LL (U9 Processors)	AC Loadline	U-Processor Line Core (9W)	—	—	AC LL same as DC LL	mΩ	7, 9, 10

Symbol	Parameter	Segment	Minimum	Typical	Maximum	Unit	Note ¹
T_ OVS_ MAX	Max Overshoot time	—	—	—	10	μs	
V_ OVS_ MAX	Max Overshoot	—	—	—	70	mV	

Notes:

- All specifications in this table are based on estimates and simulations or empirical data. These specifications will be updated with characterized data from silicon measurements at a later date.
- Each processor is programmed with a maximum valid voltage identification value (VID), which is set at manufacturing and cannot be altered. Individual maximum VID values are calibrated during manufacturing such that two processors at the same frequency may have different settings within the VID range. This differs from the VID employed by the processor during a power or thermal management event (Intel Adaptive Thermal Monitor, Enhanced Intel® SpeedStep Technology, or low-power states).
- PSx refers to the voltage regulator power state as set by the SVID protocol.
- Each processor is programmed with a maximum valid voltage identification value (VID), which is set at manufacturing and cannot be altered. Individual maximum VID values are calibrated during manufacturing such that two processors at the same frequency may have different settings within the VID range. This differs from the VID employed by the processor during a power or thermal management event (Intel Adaptive Thermal Monitor, Enhanced Intel® SpeedStep Technology, or low-power states).
- Operating voltage range in steady state.
- Load Line measured at the sense point.
- U9 Processors will have few options of VR, the data is for IMVP Spec.
- Ripple can be higher if DC TOB is below 20mV, as long as Total TOB is within -35mV/+50mV.

VDD2 DC Specifications

Memory Controller (VDD2) Supply DC Voltage and Current Specifications

Symbol	Parameter	Segment	Minimum	Typical	Maximum	Unit	Note ¹
$V_{DD2(LPDDR4x)}$	Processor I/O supply voltage for LPDDR4x	All	Typ-5%	1.115	Typ+5%	V	3,4,5
$V_{DD2(LPDDR5)}$	Processor I/O supply voltage for LPDDR5	All	Typ-5%	1.065	Typ+5%	V	3,4,5
$V_{DD2(DDR4)}$	Processor I/O supply voltage for DDR4	All	Typ-5%	1.2	Typ+5%	V	3,4,5
$V_{DD2(DDR5)}$	Processor I/O supply voltage for DDR5	All	Typ-4.5%	1.116	Typ+4.5%	V	3,4,5
TOB_{VDD2}	VDD2 Tolerance	All	VDD2 MIN <AC+DC< VDD2 MAX			V	3,4
$I_{CCMAX_VDD2(LPDDR4x)}$	Maximum Current for V_{DD2} Rail (LPDDR4x/LPDDR5)	P/U (15W)-Processor Line	—	—	2.6	A	2
$I_{CCMAX_VDD2(LPDDR5)}$	Maximum Current for V_{DD2} Rail (DDR4/DDR5)	P/U (15W)-Processor Line	—	—	2.6		
$I_{CCMAX_VDD2(LPDDR4x)}$	Maximum Current for V_{DD2} Rail (LPDDR4x/LPDDR5)	H-Processor Line	—	—	2.6	A	2
$I_{CCMAX_VDD2(LPDDR5)}$	Maximum Current for V_{DD2} Rail (DDR4/DDR5)	H-Processor Line	—	—	2.6		
$I_{CCMAX_VDD2(LPDDR4x)}$	Maximum Current for V_{DD2} Rail (LPDDR4x)	U-Processor Line (9W)	—	—	2.6	A	2

Symbol	Parameter	Segment	Minimum	Typical	Maximum	Unit	Note ¹
ICC _{MAX_VDD2} (LPDDR5)	Maximum Current for V _{DD2} Rail (LPDDR5)	U-Processor Line (9W)	—	—	2.06		
ICC _{MAX_VDD2} (DDR4)	Maximum Current for V _{DD2} Rail (DDR4)	S-Processor Line	—	—	2.6	A	2
ICC _{MAX_VDD2} (DDR5)	Maximum Current for V _{DD2} Rail (DDR5)	S-Processor Line	—	—	2.6		
ICC _{MAX_VDD2} (DDR4)	Maximum Current for V _{DD2} Rail (DDR4)	HX SBGA - Processor Line	—	—	2.6	A	2
ICC _{MAX_VDD2} (DDR5)	Maximum Current for V _{DD2} Rail (DDR5)	HX SBGA - Processor Line	—	—	2.6		

Notes:

1. All specifications in this table are based on estimates and simulations or empirical data. These specifications will be updated with characterized data from silicon measurements at a later date.
2. The current supplied to the DIMM modules is not included in this specification.
3. Includes DC error measured on package pins.
4. No requirement on the breakdown of DC noise.
5. The voltage specification requirements are measured on package pins as near as possible to the processor with an oscilloscope set to 100 MHz bandwidth, 1.5 pF maximum probe capacitance, and 1 MΩ minimum impedance. The maximum length of ground wire on the probe should be less than 5 mm. Ensure external noise from the system is not coupled into the oscilloscope probe.

VCCANA DC Specifications

VCCANA Supply DC Voltage and Current Specifications

Symbol	Parameter	Segment	Minimum	Typical	Maximum	Unit	Note ¹
V _{VCCANA}	Processor M	All	1.0	1.05	1.1	V	2,3,4
I _{CCMAX_VCCANA}	Maximum Current for V _{VCCANA} Rail	U-Processor Line (9W)	—	—	4.3	A	3

Notes:

1. All specifications in this table are based on estimates and simulations or empirical data. These specifications will be updated with characterized data from silicon measurements at a later date.
2. Includes AC and DC error, where the AC noise is bandwidth limited to under 1 MHz, measured on package pins.
3. No requirement on the breakdown of AC versus DC noise.
4. The voltage specification requirements are measured on package pins as near as possible to the processor with an oscilloscope set to 100 MHz bandwidth, 1.5 pF maximum probe capacitance, and 1 MΩ minimum impedance. The maximum length of ground wire on the probe should be less than 5 mm. Ensure external noise from the system is not coupled into the oscilloscope probe.

VCC_MIPILP DC Specifications

VCC_MIPILP Supply DC Voltage and Current Specifications

Symbol	Parameter	Segment	Minimum	Typical	Maximum	Unit	Note ¹
V _{VCC_MIPILP}	Processor Power Rail	All	1.1	1.23	1.3	V	2,3,4
I _{CCMAX_VCC_MIPILP}	Maximum Current for V _{VCC_MIPILP} Rail	U/P-Processor Line	—	—	210	mA	3
I _{CCMAX_VCC_MIPILP}	Maximum Current for V _{VCC_MIPILP} Rail	H-Processor Line	—	—	210	mA	3

Symbol	Parameter	Segment	Minimum	Typical	Maximum	Unit	Note ¹
<p>Notes:</p> <ol style="list-style-type: none"> All specifications in this table are based on estimates and simulations or empirical data. These specifications will be updated with characterized data from silicon measurements at a later date. Includes AC and DC error, where the AC noise is bandwidth limited to under 1 MHz, measured on package pins. No requirement on the breakdown of AC versus DC noise. The voltage specification requirements are measured on package pins as near as possible to the processor with an oscilloscope set to 100 MHz bandwidth, 1.5 pF maximum probe capacitance, and 1 MΩ minimum impedance. The maximum length of ground wire on the probe should be less than 5 mm. Ensure external noise from the system is not coupled into the oscilloscope probe. 							

Vcc1P05_PROC DC Specifications

Vcc1P05_PROC Supply DC Voltage and Current Specifications

Symbol	Parameter	Segment	Minimum	Typical	Maximum	Units	Notes 1,2,5
Vcc1P05_ PROC	Processor Power Rail voltage support internal Sustain and Sustain Gated rails.	All Processor Lines	—	1.05	—	V	3
TOB1P05_ PROC	Vcc1P05 Tolerance	All	± 5			%	3,5
IccMAX_1P05_ PROC	Maximum Current for Vcc1P05	H-Processor Line	—	—	850	mA	4

Symbol	Parameter	Segment	Minimum	Typical	Maximum	Units	Notes 1,2,5
ICC _{MAX_1P05_} PROC	Maximum Current for V _{cc} 1P05	P-Processor Line	—	—	850	mA	4
ICC _{MAX_1P05_} PROC	Maximum Current for V _{cc} 1P05	U 15W - Processor Line	—	—	850	mA	4
ICC _{MAX_1P05_} PROC	Maximum Current for V _{cc} 1P05	U 9W - Processor Line	—	—	850	mA	4
ICC _{MAX_1P05_} PROC	Maximum Current for V _{cc} 1P05	S-Processor Line	—	—	750	mA	4
ICC _{MAX_1P05_} PROC	Maximum Current for V _{cc} 1P05	HX, SBGA- Processor Line	—	—	750	mA	4

Symbol	Parameter	Segment	Minimum	Typical	Maximum	Units	Notes 1,2,5
<p>Notes:</p> <ol style="list-style-type: none"> All specifications in this table are based on estimates and simulations or empirical data. These specifications will be updated with characterized data from silicon measurements at a later date. Long term reliability cannot be assured in conditions above or below Maximum/Minimum functional limits. The voltage specification requirements are measured on package pins as near as possible to the processor with an oscilloscope set to 100 MHz bandwidth, 1.5 pF maximum probe capacitance, and 1 MΩ minimum impedance. The maximum length of ground wire on the probe should be less than 5 mm. Ensure external noise from the system is not coupled into the oscilloscope probe. The maximum $I_{CC_{MAX_1P05_CPU}}$ specification is preliminary and based on initial pre-silicon estimation and is subject to change. $V_{CC_{1P05_PROC}}$ may be named in other document as $V_{CC_{1P05_CPU}}$ <p>$V_{CC_{1P05_PROC}}$ momentarily may rise to 1.15V during certain scenarios, no side effects are expected.</p>							

Vcc1P8_PROC DC Specifications

Vcc1P8_PROC Supply DC Voltage and Current Specifications

Symbol	Parameter	Segment	Minimum	Typical	Maximum	Units	Notes 1,2,5
$V_{CC_{1P8_PROC}}$	Processor Power Rail voltage support PCIe (PHY)	S Processor Lines	—	1.8	—	V	3
$V_{CC_{1P8_PROC}}$	Processor Power Rail voltage support PCIe (PHY)	HX Processor Line, SBGA (55W)	—	1.8	—	V	3

Symbol	Parameter	Segment	Minimum	Typical	Maximum	Units	Notes 1,2,5
VCC _{1P8_} PROC	Processor Power Rail voltage support PCIe (PHY)	P/U 15W Processor Lines	—	1.8	—	V	3
VCC _{1P8_} PROC	Processor Power Rail voltage support PCIe (PHY)	H- Processor Lines	—	1.8	—	V	3
TOB _{1P8_} PROC	VCC _{1P8_} PROC Tolerance	All	± 4			%	3,5
AC Noise	AC Noise	S - Processor Line	—	—	+/-15 Frequency range from 1KHz Up to 10MHz +/-5 Frequency range Above 10MHz	mV	6
AC Noise	AC Noise	HX Processor Line, SBGA (55W)	—	—	+/-15 Frequency range from 1KHz Up to 10MHz +/-5 Frequency range Above 10MHz	mV	6

Symbol	Parameter	Segment	Minimum	Typical	Maximum	Units	Notes 1,2,5
AC Noise	AC Noise	H - Processor Line	—	—	+/-15 Frequency range from 1KHz Up to 10MHz +/-5 Frequency range Above 10MHz	mV	6
AC Noise	AC Noise	P/U 15W - Processor Line	—	—	+/-15 Frequency range from 1KHz Up to 10MHz +/-5 Frequency range Above 10MHz	mV	6
I _{CCMAX_1P8_PROC}	Maximum Current for V _{CC1P8_PROC}	H - Processor Line	—	—	100	mA	4
I _{CCMAX_1P8_PROC}	Maximum Current for V _{CC1P8_PROC}	P/U 15W-Processor Line	—	—	100	mA	4
I _{CCMAX_1P8_PROC}	Maximum Current for V _{CC1P8_PROC}	S - Processor Line	—	—	140	mA	4



Symbol	Parameter	Segment	Minimum	Typical	Maximum	Units	Notes 1,2,5
I _{CCMAX_1P8_PROC}	Maximum Current for V _{CC1P8_PROC}	HX Processor Line, SBGA (55W)	—	—	140	mA	4

Notes:

- All specifications in this table are based on estimates and simulations or empirical data. These specifications will be updated with characterized data from silicon measurements at a later date.
- Long term reliability cannot be assured in conditions above or below Maximum/Minimum functional limits.
- The voltage specification requirements are measured on capacitors pads near to the package, with an oscilloscope set to 100 MHz bandwidth, 1.5 pF maximum probe capacitance, and 1 MΩ minimum impedance. The maximum length of ground wire on the probe should be less than 5 mm. Ensure external noise from the system is not coupled into the oscilloscope probe.
- The maximum I_{CCMAX_1P8_CPU} specification is preliminary and based on initial pre-silicon estimation and is subject to change.
- V_{CC1P8_PROC} power rail may be named in different document as V_{CC1P8_CPU}
 For S-processor line, AC noise spec include VR self generated noise or input source AC noise that passes through to VR output and droop/overshoot due to transient load.
 For P/U 15W-processor lines, the AC noise spec only include VR self generated noise or input source AC noise that passes through to VR output.
 For HX SBGA-processor line, AC noise spec include VR self generated noise or input source AC noise that passes through to VR output and droop/overshoot due to transient load.
 For H-processor lines, the AC noise spec only include VR self generated noise or input source AC noise that passes through to VR output.

Processor Interfaces DC Specifications

DDR4 DC Specifications

DDR4 Signal Group DC Specifications

		HX/S/H/P Processor Lines		
--	--	--------------------------	--	--

		Minimum	Typical	Maximum		
V_{IL}	Input Low Voltage	—	$0.75 \cdot V_{DD2}$	$0.68 \cdot V_{DD2}$	V	2, 3, 4
V_{IH}	Input High Voltage	$0.82 \cdot V_{DD2}$	$0.75 \cdot V_{DD2}$	—	V	2, 3, 4
$R_{ON_UP(DQ)}$	Data Buffer pull-up Resistance	30	—	50	Ω	5, 12
$R_{ON_DN(DQ)}$	Data Buffer pull-down Resistance	30	—	50		
$R_{ODT(DQ)}$	On-die termination equivalent resistance for data signals	40	—	200	Ω	6, 12
$V_{ODT(DC)}$	On-die termination DC working point (driver set to receive mode)	$0.45 \cdot V_{DD2}$	—	$0.85 \cdot V_{DD2}$	V	12
$R_{ON_UP(CK)}$	Clock Buffer pull-up Resistance	25	—	45	Ω	5, 12
$R_{ON_DN(CK)}$	Clock Buffer pull-down Resistance	25	—	45	Ω	5, 12
$R_{ON_UP(CMD)}$	Command Buffer pull-up Resistance	25	—	45	Ω	5, 12
$R_{ON_DN(CMD)}$	Command Buffer pull-down Resistance	25	—	45	Ω	5, 12

Symbol	Parameter	HX/S/H/P Processor Lines			Units	Notes ¹
		Minimum	Typical	Maximum		
R _{ON_UP(CTL)}	Control Buffer pull-up Resistance	25	—	45	Ω	5, 12
R _{ON_DN(CTL)}	Control Buffer pull-down Resistance	25	—	45	Ω	5, 12
R _{ON_UP} (SM_PG_CNTL1)	System Memory Power Gate Control Buffer Pull-up Resistance	45	—	125	Ω	—
R _{ON_DN} (SM_PG_CNTL1)	System Memory Power Gate Control Buffer Pull-down Resistance	40	—	130	Ω	—
I _{LI}	Input Leakage Current (DQ, CK) 0 V 0.2* V _{DD2} 0.8* V _{DD2}	—	—	1.1	mA	—
DDR0_VREF_DQ DDR1_VREF_DQ	VREF output voltage	Trainable	V _{DD2} /2	Trainable	V	—
SM_RCOMP[0]	Command COMP Resistance	99	100	101	Ω	8

Symbol	Parameter	HX/S/H/P Processor Lines			Units	Notes ¹
		Minimum	Typical	Maximum		
SM_ RCOMP[1]	Data COMP Resistance	99	100	101	Ω	8
SM_ RCOMP[2]	ODT COMP Resistance	99	100	101	Ω	8

Symbol	Parameter	HX/S/H/P Processor Lines			Units	Notes ¹
		Minimum	Typical	Maximum		
<p>Notes:</p> <ol style="list-style-type: none"> All specifications in this table apply to all processor frequencies. Timing specifications only depend on the operating frequency of the memory channel and not the maximum rated frequency V_{IL} is defined as the maximum voltage level at a receiving agent that will be interpreted as a logical low value. V_{IH} is defined as the minimum voltage level at a receiving agent that will be interpreted as a logical high value. V_{IH} and V_{OH} may experience excursions above V_{DD2}. However, input signal drivers should comply with the signal quality specifications. Pull up/down resistance after compensation (assuming $\pm 5\%$ COMP inaccuracy). Note that BIOS power training may change these values significantly based on margin/power trade-off. Refer to processor I/O Buffer Models for I/V characteristics. ODT values after COMP (assuming $\pm 5\%$ inaccuracy). BIOS MRC can reduce ODT strength towards The minimum and maximum values for these signals are programmable by BIOS to one of the two sets. SM_RCOMP[x] resistance should be provided on the system board with 1% resistors. SM_RCOMP[x] resistors are to VSS. Values are pre-silicon estimations and are subject to change. SM_DRAMPWROK must have a maximum of 15 ns rise or fall time over $V_{DD2} * 0.30 \pm 100$ mV and the edge must be monotonic. SM_VREF is defined as $V_{DD2}/2$ for DDR4 R_{ON} tolerance is preliminary and might be subject to change. Maximum-minimum range is correct but center point is subject to change during MRC boot training. Processor may be damaged if V_{IH} exceeds the maximum voltage for extended periods. 						

DDR5 DC Specifications

DDR5 Signal Group DC Specifications

Symbol	Parameter	HX/S/H/P Processor Lines			Units	Notes ¹
		Minimum	Typical	Maximum		
V _{IL}	Input Low Voltage		0.75* V _{dd2}	0.65* V _{dd2}	V	2, 3, 4
V _{IH}	Input High Voltage	0.85* V _{dd2}	0.75* V _{dd2}	-	V	2, 3, 4
R _{ON_UP(DQ)}	Data Buffer pull-up Resistance	30		50	Ω	5, 12
R _{ON_DN(DQ)}	Data Buffer pull-down Resistance	30		50		
R _{ODT(DQ)}	On-die termination equivalent resistance for data signals	30		240	Ω	6, 12
V _{ODT(DC)}	On-die termination DC working point (driver set to receive mode)	0.4*V _{dd2}		V _{ddq}	V	12
R _{ON_UP(CK)}	Clock Buffer pull-up Resistance	30		50	Ω	5, 12
R _{ON_DN(CK)}	Clock Buffer pull-down Resistance	30		50	Ω	5, 12
R _{ON_UP(CMD)}	Command Buffer pull-up Resistance	30		50	Ω	5, 12
R _{ON_DN(CMD)}	Command Buffer pull-down Resistance	30		50	Ω	5, 12
R _{ON_UP(CTL)}	Control Buffer pull-up Resistance	30		50	Ω	5, 12

Symbol	Parameter	HX/S/H/P Processor Lines			Units	Notes ¹
		Minimum	Typical	Maximum		
R _{ON_DN(CTL)}	Control Buffer pull-down Resistance	30		50	Ω	5, 12
R _{ON_UP} (SM_PG_CNTL1)	System Memory Power Gate Control Buffer Pull-up Resistance				Ω	—
R _{ON_DN} (SM_PG_CNTL1)	System Memory Power Gate Control Buffer Pull-down Resistance				Ω	—
I _{LI}	Input Leakage Current (DQ, CK) 0 V, 0.2* VDD2, 0.8* VDD2			0.2	mA	—
DDR0_VREF_DQ DDR1_VREF_DQ	VREF output voltage	NA	NA	NA	V	—
SM_RCOMP[0]	Command COMP Resistance	99 - H/P Processor lines only	100 - H/P Processor lines only	101 - H/P Processor lines only	Ω	8
SM_RCOMP[1]	Data COMP Resistance	99 - H/P Processor lines only	100 - H/P Processor lines only	101 - H/P Processor lines only	Ω	8

Symbol	Parameter	HX/S/H/P Processor Lines			Units	Notes ¹
		Minimum	Typical	Maximum		
SM_RCOMP[2]	ODT COMP Resistance	99 - H/P Processor lines only	100 - H/P Processor lines only	101 - H/P Processor lines only	Ω	8

Notes:

1. All specifications in this table apply to all processor frequencies. Timing specifications only depend on the operating frequency of the memory channel and not the maximum rated frequency
2. V_{IL} is defined as the maximum voltage level at a receiving agent that will be interpreted as a logical low value.
3. V_{IH} is defined as the minimum voltage level at a receiving agent that will be interpreted as a logical high value.
4. V_{IH} and V_{OH} may experience excursions above V_{DD2} . However, input signal drivers should comply with the signal quality specifications.
5. Pull up/down resistance after compensation (assuming $\pm 5\%$ COMP inaccuracy). Note that BIOS power training may change these values significantly based on margin/power trade-off. Refer to processor I/O Buffer Models for I/V characteristics.
6. ODT values after COMP (assuming $\pm 5\%$ inaccuracy). BIOS MRC can reduce ODT strength towards
7. The minimum and maximum values for these signals are programmable by BIOS to one of the two sets.
8. SM_RCOMP[x] resistance should be provided on the system board with 1% resistors. SM_RCOMP[x] resistors are to VSS. Values are pre-silicon estimations and are subject to change.
9. SM_DRAMPWROK must have a maximum of 15 ns rise or fall time over $V_{DD2} * 0.30 \pm 100$ mV and the edge must be monotonic.
10. SM_VREF is defined as $V_{DD2}/2$ for DDR5
11. RON tolerance is preliminary and might be subject to change.
12. Maximum-minimum range is correct but center point is subject to change during MRC boot training.
13. Processor may be damaged if V_{IH} exceeds the maximum voltage for extended periods.

LPDDR4x DC Specification

LPDDR4x Signal Group DC Specifications

Symbol	Parameter	H /P/U Processor Line			Units	Notes ¹
		Minimum	Typical	Maximum		
V_{IL}	Input Low Voltage	—	$0.2 \cdot V_{dd2}$	$0.08 \cdot V_{dd2}$	V	2, 3, 4
V_{IH}	0 = Input High Voltage	$0.35 \cdot V_{dd2}$	$0.2 \cdot V_{dd2}$	—	V	2, 3, 4
$R_{ON_UP(DQ)}$	Data Buffer pull-up Resistance	30	—	50	Ω	5, 12
$R_{ON_DN(DQ)}$	Data Buffer pull-down Resistance	30	—	50	Ω	5, 12
$R_{ODT(DQ)}$	On-die termination equivalent resistance for data signals	40	—	200	Ω	6, 12
$V_{ODT(DC)}$	On-die termination DC working point (driver set to receive mode)	$0.1 \cdot V_{dd2}$	—	$0.3 \cdot V_{dd2}$	V	10
$R_{ON_UP(CK)}$	Clock Buffer pull-up Resistance	30	—	45	Ω	5, 12
$R_{ON_DN(CK)}$	Clock Buffer pull-down Resistance	30	—	45	Ω	5, 12
$R_{ON_UP(CMD)}$	Command Buffer pull-up Resistance	30	—	45	Ω	5, 12

Symbol	Parameter	H /P/U Processor Line			Units	Notes ¹
		Minimum	Typical	Maximum		
R _{ON_DN} (CMD)	Command Buffer pull-down Resistance	30	—	45	Ω	5, 12
R _{ON_UP} (CTL)	Control Buffer pull-up Resistance	30	—	45	Ω	5, 12
R _{ON_DN} (CTL)	Control Buffer pull-down Resistance	30	—	45	Ω	5, 12
R _{ON_UP} (SM_PG_CNTL1)	System Memory Power Gate Control Buffer Pull-up Resistance	N/A	—	N/A	Ω	N/A
R _{ON_DN} (SM_PG_CNTL1)	System Memory Power Gate Control Buffer Pull- down Resistance	N/A	—	N/A	Ω	N/A
I _{LI}	Input Leakage Current (DQ, CK) 0 V 0.2* V _{DD2} 0.8* V _{DD2}	—	—	1.1	m A	—
DDR0_VREF_DQ DDR1_VREF_DQ DDR_VREF_CA	VREF output voltage	Trainable			V	—
SM_RCOMP[0]	Command COMP Resistance	99	100	101	Ω	8

Symbol	Parameter	H /P/U Processor Line			Units	Notes ¹
		Minimum	Typical	Maximum		
SM_RCOMP[1]	Data COMP Resistance	99	100	101	Ω	8
SM_RCOMP[2]	ODT COMP Resistance	99	100	101	Ω	8

Symbol	Parameter	H /P/U Processor Line			Units	Notes ¹
		Minimum	Typical	Maximum		
<p>Notes:</p> <ol style="list-style-type: none"> 1. Unless otherwise noted, all specifications in this table apply to all processor frequencies. Timing specifications only depend on the operating frequency of the memory channel and not the maximum rated frequency 2. V_{IL} is defined as the maximum voltage level at a receiving agent that will be interpreted as a logical low value. 3. V_{IH} is defined as the minimum voltage level at a receiving agent that will be interpreted as a logical high value. 4. V_{IH} and V_{OH} may experience excursions above V_{DD2}. However, input signal drivers should comply with the signal quality specifications. 5. Pull up/down resistance after compensation (assuming $\pm 5\%$ COMP inaccuracy). Note that BIOS power training may change these values significantly based on margin/power trade-off. Refer to processor I/O Buffer Models for I/V characteristics. 6. ODT values after COMP (assuming $\pm 5\%$ inaccuracy). BIOS MRC can reduce ODT strength towards 7. The minimum and maximum values for these signals are programmable by BIOS to one of the two sets. 8. SM_RCOMP[x] resistance should be provided on the system board with 1% resistors. SM_RCOMP[x] resistors are to VSS. Values are pre-silicon estimations and are subject to change. 9. SM_DRAMPWROK must have a maximum of 15 ns rise or fall time over $V_{DD2} * 0.30 \pm 100$ mV and the edge must be monotonic. 10. SM_VREF is defined as $V_{DD2}/2$ for DDR4 11. R_{ON} tolerance is preliminary and might be subject to change. 12. Maximum-minimum range is correct but center point is subject to change during MRC boot training. 13. Processor may be damaged if V_{IH} exceeds the maximum voltage for extended periods. 						

LPDDR5 DC Specification

LPDDR5 Signal Group DC Specifications

Symbol	Parameter	H/P /U Processor Line			Units	Notes ¹
		Minimum	Typical	Maximum		
V _{IL}	Input Low Voltage	-	0.15*V _d d2	0.06*V _d d2	V	2, 3, 4
V _{IH}	Input High Voltage	0.24*V _d d2	0.15*V _d d2	-	V	2, 3, 4
R _{ON_UP(DQ)}	Data Buffer pull-up Resistance	30		50	Ω	5,12
R _{ON_DN(DQ)}	Data Buffer pull-down Resistance	30		50		
R _{ODT(DQ)}	On-die termination equivalent resistance for data signals	30		240	Ω	6, 12
V _{ODT(DC)}	On-die termination DC working point (driver set to receive mode)	0		0.6*V _d d2	V	12
R _{ON_UP(CK)}	Clock Buffer pull-up Resistance	30		50	Ω	5, 12
R _{ON_DN(CK)}	Clock Buffer pull-down Resistance	30		50	Ω	5, 12
R _{ON_UP(CMD)}	Command Buffer pull-up Resistance	30		50	Ω	5, 12
R _{ON_DN(CMD)}	Command Buffer pull-down Resistance	30		50	Ω	5, 12
R _{ON_UP(CTL)}	Control Buffer pull-up Resistance	30		50	Ω	5, 12

Symbol	Parameter	H/P /U Processor Line			Units	Notes ¹
		Minimum	Typical	Maximum		
R _{ON_DN(CTL)}	Control Buffer pull-down Resistance	30		50	Ω	5, 12
R _{ON_UP} (SM_PG_CNTL1)	System Memory Power Gate Control Buffer Pull-up Resistance				Ω	—
R _{ON_DN} (SM_PG_CNTL1)	System Memory Power Gate Control Buffer Pull-down Resistance				Ω	—
I _{LI}	Input Leakage Current (DQ, CK) 0 V 0.2* V _{DD2} 0.8* V _{DD2}				mA	—
DDR0_VREF_DQ DDR1_VREF_DQ DDR_VREF_CA	VREF output voltage	NA	NA	NA	V	—
SM_RCOMP[0]	Command COMP Resistance	99	100	101	Ω	
SM_RCOMP[1]	Data COMP Resistance	99	100	101	Ω	
SM_RCOMP[2]	ODT COMP Resistance	99	100	101	Ω	



Symbol	Parameter	H/P /U Processor Line			Units	Notes ¹
		Minimum	Typical	Maximum		
<p>Notes:</p> <ol style="list-style-type: none"> 1. Unless otherwise noted, all specifications in this table apply to all processor frequencies. Timing specifications only depend on the operating frequency of the memory channel and not the maximum rated frequency 2. V_{IL} is defined as the maximum voltage level at a receiving agent that will be interpreted as a logical low value. 3. V_{IH} is defined as the minimum voltage level at a receiving agent that will be interpreted as a logical high value. 4. V_{IH} and V_{OH} may experience excursions above V_{DD2}. However, input signal drivers should comply with the signal quality specifications. 5. Pull up/down resistance after compensation (assuming $\pm 5\%$ COMP inaccuracy). Note that BIOS power training may change these values significantly based on margin/power trade-off. Refer to processor I/O Buffer Models for I/V characteristics. 6. ODT values after COMP (assuming $\pm 5\%$ inaccuracy). BIOS MRC can reduce ODT strength towards 7. The minimum and maximum values for these signals are programmable by BIOS to one of the two sets. 8. SM_RCOMP[x] resistance should be provided on the system board with 1% resistors. SM_RCOMP[x] resistors are to VSS. Values are pre-silicon estimations and are subject to change. 9. SM_DRAMPWROK must have a maximum of 15 ns rise or fall time over $V_{DD2} * 0.30 \pm 100$ mV and the edge must be monotonic. 10. SM_VREF is defined as $V_{DD2}/2$ for DDR4 11. R_{ON} tolerance is preliminary and might be subject to change. 12. Maximum-minimum range is correct but center point is subject to change during MRC boot training. 13. Processor may be damaged if V_{IH} exceeds the maximum voltage for extended periods. 						

PCI Express* Graphics (PEG) Group DC Specifications

PCI Express* Graphics (PEG) Group DC Specifications

Symbol	Parameter	Min	Typ	Max	Units	Notes ¹
Z _{TX-DIFF-DC}	DC Differential Tx Impedance	80	100	120	Ω	1, 5
Z _{RX-DC}	DC Common Mode Rx Impedance	40	50	60	Ω	1, 4
Z _{RX-DIFF-DC}	DC Differential Rx Impedance	80	—	120	Ω	1
PEG_RCOMP	resistance compensation	24.75	25	25.25	Ω	2, 3

Notes:

1. Refer to the PCI Express Base Specification for more details.
2. Low impedance defined during signaling. Parameter is captured for 5.0 GHz by RLTX-DIFF.
3. PEG_RCOMP resistance should be provided on the system board with 1% resistors. COMP resistors are to VCCIO_OUT. PEG_RCOMP- Intel allows using 24.9 Ω 1% resistors.
4. DC impedance limits are needed to ensure Receiver detect.
5. The Rx DC Common Mode Impedance should be present when the Receiver terminations are first enabled to ensure that the Receiver Detect occurs properly. Compensation of this impedance can start immediately and the 15 Rx Common Mode Impedance (constrained by RLRX-CM to 50 Ω ±20%) should be within the specified range by the time Detect is entered.

Digital Display Interface (DDI) DC Specifications

DSI HS Transmitter DC Specifications

Parameter	Description	Minimum	Nom	Max	Units	Notes ¹
V _{CMTX}	HS transmit static common-mode voltage	150	200	250	mV	1

Parameter	Description	Minimum	Nom	Max	Units	Notes ¹
$ \Delta V_{\text{CMTX}(1,0)} $	V_{CMTX} mismatch when output is Differential-1 or Differential-0			5	mV	2
$ V_{\text{OD}} $	HS transmit differential voltage	140	200	270	mV	1
$ \Delta V_{\text{OD}} $	V_{OD} mismatch when output is Differential-1 or Differential-0			14	mV	2
V_{OHHS}	HS output high voltage			360	mV	1
Z_{OS}	Single ended output impedance	40	50	62.5	Ω	
ΔZ_{OS}	Single ended output impedance mismatch			10	%	

Notes:

- Value when driving into load impedance anywhere in the ZID range.
- A transmitter should minimize ΔV_{OD} and $\Delta V_{\text{CMTX}(1,0)}$ in order to minimize radiation, and optimize signal integrity

DSI LP Transmitter DC Specifications

Parameter	Description	Minimum	Nominal	Maximum	Units	Notes ¹
V_{OH}	Thevenin output high level	1.1	1.05	1.3	V	1
		0.95		1.3	V	2

Parameter	Description	Minimum	Nominal	Maximum	Units	Notes ¹
V_{OL}	Thevenin output low level	-50		50	mV	
Z_{OLP}	Output impedance of LP transmitter	110			Ω	3
V_{pin}	Pin signal voltage range	-50		1350	mV	
I_{LEAK}	Pin Leakage current	-10		10	μA	4
$V_{GND SH}$	Ground shift	-50		50	mV	
$V_{pin(ABS MAX)}$	Transient pin voltage level	-0.15		1.45	V	6
$T_{V_{pin(ABS MAX)}}$	Maximum transient time above $V_{PIN(MAX)}$ or below $V_{PIN(MIN)}$			20	ns	5

Notes:

1. Applicable when the supported data rate \leq 1.5 Gbps.
2. Applicable when the supported data rate $>$ 1.5 Gbps.
3. Though no maximum value for Z_{OLP} is specified, the LP transmitter output impedance shall ensure the $TRLP/TFLP$ specification is met.
4. The voltage overshoot and undershoot beyond the V_{PIN} is only allowed during a single 20 ns window after any LP-0 to LP-1 transition or vice versa. For all other situations it must stay within the V_{PIN} range.
5. This value includes ground shift.

Display Audio and Utility Pins DC Specification

Symbol	Parameter	Minimum	Typical	Maximum	Units
V_{OL}	Output Low Voltage	—	—	$V_{CCIO} * 0.1$	V
V_{OH}	Output High Voltage	$V_{CCIO} * 0.9$	—	—	V
Output Impedance	Output Impedance	—	50	—	Ω
V_{IL}	Input Low Voltage	—	—	$V_{CCIO} * 0.25$	V
V_{IH}	Input Low Voltage	$V_{CCIO} * 0.75$	—	—	V

1. DC specification for Disp_Utills_1 and Disp_Utills_2 signals.
2. DC specification for: PROC_AUDOUT, PROC_AUDIN, PROC_AUDCLK.

CMOS DC Specifications

CMOS Signal Group DC Specifications

Symbol	Parameter	Minimum	Maximum	Units	Notes ¹
V_{IL}	Input Low Voltage	—	$V_{CC1p05_PROC} * 0.3$	V	2, 5
V_{IH}	Input High Voltage	$V_{CC1p05_PROC} * 0.7$	—	V	2, 4, 5
R_{ON}	Buffer on Resistance	20	70	Ω	-

Symbol	Parameter	Minimum	Maximum	Units	Notes ¹
I_{LI}	Input Leakage Current	—	±150	μA	3

Notes:

- All specifications in this table apply to all processor frequencies.
- The V_{CC1P05_PROC} referred to in these specifications refers to instantaneous $V_{CC1P05_PROC/IO}$.
- For V_{IN} between "0" V and V_{CC1P05_PROC} . Measured when the driver is tri-stated.
- V_{IH} may experience excursions above V_{CC1P05_PROC} . However, input signal drivers should comply with the signal quality specifications.
- Refer to the processor *I/O Buffer Models* for I/V characteristics.

GTL and OD DC Specification

GTL Signal Group and Open Drain Signal Group DC Specifications

Symbol	Parameter	Minimum	Maximum	Units	Notes ¹
V_{IL}	Input Low Voltage (TAP, except PROC_JTAG_TCK, PROC_JTAG_TRST#)	—	0.6*Vcc	V	2, 5
V_{IH}	Input High Voltage (TAP, except PROC_JTAG_TCK, PROC_JTAG_TRST#)	0.72*Vcc	—	V	2, 4, 5
V_{IL}	Input Low Voltage (PROC_JTAG_TCK, PROC_JTAG_TRST#)	—	0.3*Vcc	V	2, 5
V_{IH}	Input High Voltage (PROC_JTAG_TCK, PROC_JTAG_TRST#)	0.7*Vcc	—	V	2, 4, 5
$V_{HYSTERESIS}$	Hysteresis Voltage	0.2*Vcc	—	V	-

Symbol	Parameter	Minimum	Maximum	Units	Notes ¹
R _{ON}	Buffer on Resistance (TDO)	7	17	Ω	-
V _{IL}	Input Low Voltage (other GTL)	—	0.6*V _{CC}	V	2, 5
V _{IH}	Input High Voltage (other GTL)	0.72*V _{CC}	—	V	2, 4, 5
R _{ON}	Buffer on Resistance (BPM)	12	28	Ω	-
R _{ON}	Buffer on Resistance (other GTL)	16	24	Ω	-
I _{LI}	Input Leakage Current	—	±150	μA	3

Notes:

1. All specifications in this table apply to all processor frequencies.
2. The V_{CC} referred to in these specifications refers to instantaneous V_{CC1P05_PROC/IO}.
3. For V_{IN} between 0 V and V_{CC}. Measured when the driver is tri-stated.
4. V_{IH} and V_{OH} may experience excursions above V_{CC}. However, input signal drivers should comply with the signal quality specifications.
5. Refer to the processor *I/O Buffer Models* for I/V characteristics.

PECI DC Characteristics

The Peci interface operates at a nominal voltage set by V_{CC1P05_PROC}. The set of DC electrical specifications shown in the following table is used with devices normally operating from a V_{CC1P05_PROC} interface supply.

V_{CC1P05_PROC} nominal levels will vary between processor families. All Peci devices will operate at the V_{CC1P05_PROC} level determined by the processor installed in the system.

PECI DC Electrical Limits

Symbol	Definition and Conditions	Minimum	Maximum	Units	Notes ¹
--------	---------------------------	---------	---------	-------	--------------------

Symbol	Definition and Conditions	Minimum	Maximum	Units	Notes ¹
R_{up}	Internal pull up resistance	15	45	Ω	3
V_{in}	Input Voltage Range	-0.15	V_{cc1p05_PROC} + 0.15	V	-
$V_{hysteresis}$	Hysteresis	0.1 * V_{cc1p05_PROC}	—	V	-
V_{IL}	Input Voltage Low- Edge Threshold Voltage	0.275 * V_{cc1p05_PROC}	0.525 * V_{cc1p05_PROC}	V	-
V_{IH}	Input Voltage High- Edge Threshold Voltage	0.550 * V_{cc1p05_PROC}	0.725 * V_{cc1p05_PROC}	V	-
C_{bus}	Bus Capacitance per Node	—	10	pF	-
C_{pad}	Pad Capacitance	0.7	1.8	pF	-
I_{leak00}	leakage current @ 0 V	—	0.25	mA	-
I_{leak10}	leakage current @ V_{cc1p05}	—	0.15	mA	-

Symbol	Definition and Conditions	Minimum	Maximum	Units	Notes ¹
<p>Notes:</p> <ol style="list-style-type: none"> VCC_{1p05_PROC} supplies the PECI interface. PECI behavior does not affect VCC_{1p05_PROC} minimum / maximum specifications. The leakage specification applies to powered devices on the PECI bus. The PECI buffer internal pull up resistance measured at 0.75* VCC_{1p05_PROC}. 					

Input Device Hysteresis

The input buffers in both client and host models should use a Schmitt-triggered input design for improved noise immunity. Use the following figure as a guide for input buffer design.

Input Device Hysteresis

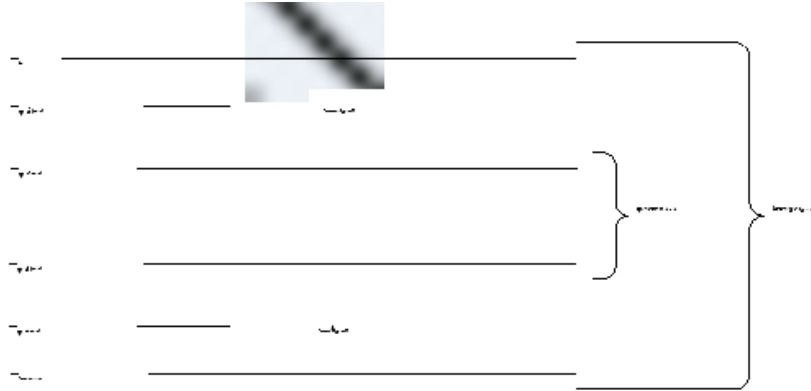

Package Mechanical Specifications

Package Mechanical Attributes

The SProcessor Lines use a Flip Chip technology available in a Land Grid Array (LGA) package and HX Processor Lines use a Flip Chip technology available in a Ball Grid Array (BGA). The following table provides an overview of the package mechanical attributes. For specific dimensions (die size, die location, and so on), refer to the processor package mechanical drawings.

S/S Refresh LGA Processor Package Mechanical Attributes

Package	Parameter	S LGA Processor Lines

Package	Parameter	S LGA Processor Lines
Package Technology	Package Type	Flip Chip Land Grid Array
	Interconnect	Land Grid Array (LGA)
	Lead Free	N/A
	Halogenated Flame Retardant Free	Yes
Package Configuration	Solder Ball Composition	N/A
	Ball/Pin Count	1700
	Grid Array Pattern	Grid Array
	Land Side Capacitors	Yes
	Die Side Capacitors	Yes
	Die Configuration	Single Die Single-Chip Package with HIS
Package Dimensions	Nominal Package Size	45.0 x 37.5 mm
	Z	Substrate Z=1.116 mm +/-0.95 Die Z is 0.37 mm
	Minimum Ball/Pin pitch	0.8 mm

Parameter	Minimum	Maximum
Static Compressive per Contact	0.098 N [10gf]	0.254 N [25gf]
Static Pre-Load Compressive	400 N [80 lbf; End of life]	845 N [190 lbf; Beginning of life]
Static Total Compressive	534 N [120 lbf, Beginning of Life] 400 N [80 lbf; End of life]	1068 N [240 lbf; Beginning of life]
Dynamic Compressive	N/A	489.5 N [110 lbf]
Board Transient Bend Strain	N/A	600ue
Maximum Heatsink Mask	N/A	550 g
PnP cover vertical removal for SMT	0.5 lb	Not recommended for system assy

HX BGA Processor Package Mechanical Attributes

Package	Parameter	HX Processor Lines
Package Technology	Package Type	Flip Chip Ball Grid Array
	Interconnect	Ball Grid Array (BGA)
	Lead Free	N/A
	Halogenated Flame Retardant Free	Yes

Package	Parameter	HX Processor Lines
Package Configuration	Solder Ball Composition	Yes
	Ball/Pin Count	1964
	Grid Array Pattern	Grid Array
	Land Side Capacitors	Yes
	Die Side Capacitors	Yes (resistor/Capacitors)
	Die Configuration	Single Die Single-Chip Package
Package Dimensions	Nominal Package Size	45.0 x 37.5 mm
	Z	Substrate Z = 1.119+/-0.095 mm 2.005±0.114 (BOTTOM OF BGA TO TOP OF DIE)
	Minimum Ball/Pin pitch	0.8 mm

The P/H/U Processor Lines use a Flip Chip technology available in a Ball Grid Array (BGA) package. The following table provides an overview of the package mechanical attributes. For specific dimensions (die size, die location, and so on), refer to the processor package mechanical drawings.

H/P/U15 - Processor Package Mechanical Attributes

Package	Parameter	P/H/U15 Processor Line
---------	-----------	------------------------

Package	Parameter	P/H/U15 Processor Line
Package Technology	Package Type	Flip Chip Ball Grid Array
	Interconnect	Ball Grid Array (BGA)
	Lead Free	Yes
	Halogenated Flame Retardant Free	Yes
Package Configuration	Solder Ball Composition	SAC405
	Ball/Pin Count	1744
	Grid Array Pattern	Balls anywhere
	Land Side Capacitors	Yes
	Die Side Capacitors	No
	Die Configuration	2 Dice Multi Chip package (MCP)
Package Dimensions	Nominal Package Size	25 x 50 mm
	Z	Substrate Z = 0.594+/-0.08mm 1.185±0.096 (BOTTOM OF BGA TO TOP OF DIE)
	Minimum Ball/Pin pitch	0.65 mm BP

The U9 Processor Lines use a Flip Chip technology available in a Ball Grid Array (BGA) package. The following table provides an overview of the package mechanical attributes. For specific dimensions (die size, die location, and so on), refer to the processor package mechanical drawings.

U9 - Processor Package Mechanical Attributes

Package	Parameter	U9 Processor Line
Package Technology	Package Type	Flip Chip Ball Grid Array
	Interconnect	Ball Grid Array (BGA)
	Lead Free	Yes
	Halogenated Flame Retardant Free	Yes
Package Configuration	Solder Ball Composition	SAC405
	Ball/Pin Count	1781
	Grid Array Pattern	Balls anywhere
	Land Side Capacitors	Yes
	Die Side Capacitors	No
	Die Configuration	2 Dice Multi Chip package (MCP)
Package Dimensions	Nominal Package Size	19 x 28.5 mm

Package	Parameter	U9 Processor Line
	Z	Substrate Z = 584±0.065 1.033±0.079 (BOTTOM OF BGA TO TOP OF DIE)
	Minimum Ball/Pin pitch	0.4 mm BP

Package Storage Specifications

Parameter	Description	Minimum	Maximum
T _{ABSOLUTE STORAGE}	The non-operating device storage temperature. Damage (latent or otherwise) may occur when subjected to this temperature for any length of time in Intel Original sealed moisture barrier bag and / or box.	-25°C	125°C
T _{SUSTAINED STORAGE}	The ambient storage temperature limit (in shipping media) for the sustained period of time	-5°C	40°C
RH _{SUSTAINED STORAGE}	The maximum device storage relative humidity for the sustained period of time as specified below in Intel Original sealed moisture barrier bag and / or box	60%@ 24°C	

Parameter	Description	Minimum	Maximum
TIME _{SUSTAINED STORAGE}	Maximum time: associated with customer shelf life in Intel Original sealed moisture barrier bag and / or box	NA	Moisture Sensitive Devices: 60 months from bag seal date; Non-moisture sensitive devices: 60 months from lot date
Storage Conditions	Processors in a non-operational state may be installed in a platform, in a tray, boxed, or loose and may be sealed in airtight package or exposed to free air. Under these conditions, processor landings should not be connected to any supply voltages, have any I/Os biased, or receive any clocks. Upon exposure to "free air" (that is, unsealed packaging or a device removed from packaging material), the processor should be handled in accordance with moisture sensitivity labeling (MSL) as indicated on the packaging material. Boxed Land Grid Array packaged (LGA) processors are MSL 1 ('unlimited' or unaffected) as they are not heated in order to be inserted in the socket.		
<p>Notes:</p> <ol style="list-style-type: none"> 1. T_{ABSOLUTE STORAGE} applies to the un-assembled component only and does not apply to the shipping media, moisture barrier bags or desiccant. Refers to a component device that is not assembled in a board or socket that is not to be electrically connected to a voltage reference or I/O signals. 2. Specified temperatures are based on data collected. Exceptions for surface mount re-flow are specified by applicable JEDEC J-STD-020 documents. The JEDEC, J-STD-020 moisture level rating and associated handling practices apply to all moisture sensitive devices removed from the moisture barrier bag. 3. Post board attaches storage temperature limits are not specified for non-Intel branded boards. Consult your board manufacturer for storage specifications. 			

CPU And Device IDs

CPUID

CPUID Format

SKU	CPUID	Reserved [31:28]	Extended Family [27:20]	Extended Model [19:16]	Reserved [15:14]	Processor Type [13:12]	Family Code [11:8]	Model Number [7:4]	Stepping ID [3:0]
S-processor 8+8	90672h	Reserved	0000000b	1001b	Reserved	00b	0110b	111b	0010b
HX SBGA - processor 8+8	90672h	Reserved	0000000b	1001b	Reserved	00b	0110b	111b	0010b
S-processor 6+0	90675h	Reserved	0000000b	1001b	Reserved	00b	0110b	111b	0101b
P-processor 6+8	906A3h	Reserved	0000000b	1001b	Reserved	00b	0110b	1010b	0011b
H-processor 6+8	906A3h	Reserved	0000000b	1001b	Reserved	00b	0110b	1010b	0011b
U15-processor 2+8	906A4h	Reserved	0000000b	1001b	Reserved	00b	0110b	1010b	0100b
U9-processor 2+8	906A4h	Reserved	0000000b	1001b	Reserved	00b	0110b	1010b	0100b

- The Extended Family, Bits [27:20] are used in conjunction with the Family Code, specified in Bits [11:8], to indicate whether the processor belongs to Intel® Core™ processor family.
- The Extended Model, Bits [19:16] in conjunction with the Model Number, specified in Bits [7:4], are used to identify the model of the processor within the processor's family.
- The Family Code corresponds to Bits [11:8] of the EDX register after RESET, Bits [11:8] of the EAX register after the CPUID instruction is executed with a 1 in the EAX register, and

the generation field of the Device ID register accessible through Boundary Scan.

- The Model Number corresponds to Bits [7:4] of the EDX register after RESET, Bits [7:4] of the EAX register after the CPUID instruction is executed with a 1 in the EAX register, and the model field of the Device ID register accessible through Boundary Scan.
- The Stepping ID in Bits [3:0] indicates the revision number of that model.
- When EAX is initialized to a value of '1', the CPUID instruction returns the Extended Family, Extended Model, Processor Type, Family Code, Model Number and Stepping ID value in the EAX register. Note that the EDX processor signature value after reset is equivalent to the processor signature output value in the EAX register.

Cache and TLB descriptor parameters are provided in the EAX, EBX, ECX and EDX registers after the CPUID instruction is executed with a 2 in the EAX register.

PCI Configuration Header

Every PCI-compatible function has a standard PCI configuration header, as shown in the table below. This includes mandatory registers (Bold) to determine which driver to load for the device. Some of these registers define ID values for the PCI function, which are described in this chapter.

PCI Configuration Header

Byte3	Byte2	Byte1	Byte0	Address
Device ID		Vendor ID (0x8086)		00h
Status		Command		04h
Class Code			Revision ID	08h
BIST	Header Type	Latency Timer	Cache Line Size	0Ch
Base Address Register0 (BAR0)				10h
Base Address Register1 (BAR1)				14h
Base Address Register2 (BAR2)				18h

Byte3	Byte2	Byte1	Byte0	Address
Base Address Register3 (BAR3)				1Ch
Base Address Register4 (BAR4)				20h
Base Address Register5 (BAR5)				24h
Card-bus CIS Pointer				28h
Subsystem ID		Subsystem Vendor ID		2Ch
Expansion ROM Base Address				30h
Reserved			Capabilities Pointer	34h
Reserved				38h
Maximum Latency	Minimum Grant	Interrupt Pin	Interrupt Line	3Ch

Device IDs

This section specifies the device IDs of the processor.

Host Device ID (DID0)

Platform	Device ID
S LGA 8+8	4660h
S LGA 8+4	4668h

Platform	Device ID
S LGA 6+4	4648h
S LGA 6+0	4650h
S LGA 4+0	4630h
S LGA 2+0	4610h
HX SBGA 8+8	4637h
HX SBGA 6+8	463Bh
HX SBGA 4+8	4623h
HX SBGA 4+8	462Bh
H 6+8	4641h
H 6+4	4649h
H 4+8	4621h
H 4+4	4629h
P 6+8	4641h
P 4+8	4621h
P 2+8	4601h
U15 2+8	4601h
U15 2+4	4609h
U15 1+4	4619h

Platform	Device ID
U9 2+8	4602h
U9 2+4	460Ah
U9 1+4	461Ah

Processor Graphics Device ID (DID2)

Platform	Processor Step	GT SKU	Device ID
S LGA 8+8	C0	32EU	4680h
S LGA 8+4	C0	32EU	4680h
S LGA 6+4	C0	32EU	4680h
S LGA 6+0	C0	24EU	4682h
HX SBGA 8+8	C0	32EU	4688h
HX SBGA 6+8	C0	32EU	4688h
HX SBGA 4+8	C0	32EU	4688h
HX SBGA 4+4	C0	16EU	468Bh
S LGA 6+0	H0	32EU	4690h
S LGA 6+0	H0	24EU	4692h
S LGA 6+0	H0	16EU	4693h

Platform	Processor Step	GT SKU	Device ID
P 6+8	L0	96EU	46A6h
H 6+8	L0	96EU	46A6h
H 6+4	L0	64EU	46A3h
H 4+8	L0	80EU	46A6h
H 4+4	L0	48EU	46A3h
P 6+8	L0	96EU	46A6h
P 4+8	L0	80EU	46A6h
P 2+8	L0	64EU	46B3h
U15 2+8	R0	96EU	46A8h
U15 2+8	R0	80EU	46A8h
U15 2+4	R0	64EU	46B3h
U15 1+4	R0	48EU	46B3h
U9 2+8	R0	96EU	46AAh
U9 2+8	R0	80EU	46AAh
U9 2+4	R0	64EU	46C3h
U9 1+4	R0	48EU	46C3h

Other Device ID

Device	Processor Line	Bus / Device / Function	DID
PCIe RC 010 G5	S, H, HX, P, U15	0 / 1 / 0	460Dh
PCIe RC 011 G5	S, HX	0 / 1 / 1	462Dh
Dynamic Tuning Technology (DTT)	S, H, HX, P, U	0 / 4 / 0	461Dh
IPU(IMGU)	H, P, U	0 / 5 / 0	465Dh
PCIe RC 060 (x4) G4	S, H, HX, P, U	0 / 6 / 0	464Dh
PCIe RC 062 (x4) G4	H, P, U15	0 / 6 / 2	463Dh
TBT PCIe0	H, P, U	0 / 7 / 0	466Eh
TBT PCIe1	H, P, U	0 / 7 / 1	463Fh
TBT PCIe2	H, P, U15	0 / 7 / 2	462Fh
TBT PCIe3	H, P, U15	0 / 7 / 3	461Fh
Gauss Newton Algorithm (GNA)	S, H, HX, P, U	0 / 8 / 0	464Fh
Intel® Trace Hub	S, H, HX, P, U	0 / 9 / 0	466Fh
Crash Log & Telemetry	S, H, HX, P, U	0 / 10 / 0	467Dh
USB xHCI	H, P, U	0 / 13 / 0	461Eh

Device	Processor Line	Bus / Device / Function	DID
USB xHCI	H, P, U	0 / 13 / 1	460Eh
TBT DMA0	H, P, U	0 / 13 / 2	463Eh
TBT DMA1	H, P, U	0 / 13 / 3	466Dh
Intel® Volume Management Device (VMD)	S,H, HX, P, U	0 / 14 / 0	467Fh